

# AIRFLOW™

## Loovents and Humidivents

Instructions for installation, maintenance and safe use.

Fixing and operating instructions for the Airflow Loovent models 01, 02/2S, 03, 06, L11, Airflow Humidivent models H50, H50N, H51, H56 and the Loovent Window Kit.

**Note to installer** - Please leave these instructions with the occupier of the premises.

Contents	page
Section 1: Options	2
Section 2: Positioning	3
Section 3: First steps	3
Section 4: Wiring arrangements	5
Section 5: Installation on the wall surface	6
Section 6: Installation within the wall	7
Section 7: Installation on the ceiling surface	9
Section 8: Installation within the ceiling	10
Section 9: Installation in a window	11
Section 10: Testing	13
Section 11: User information	16

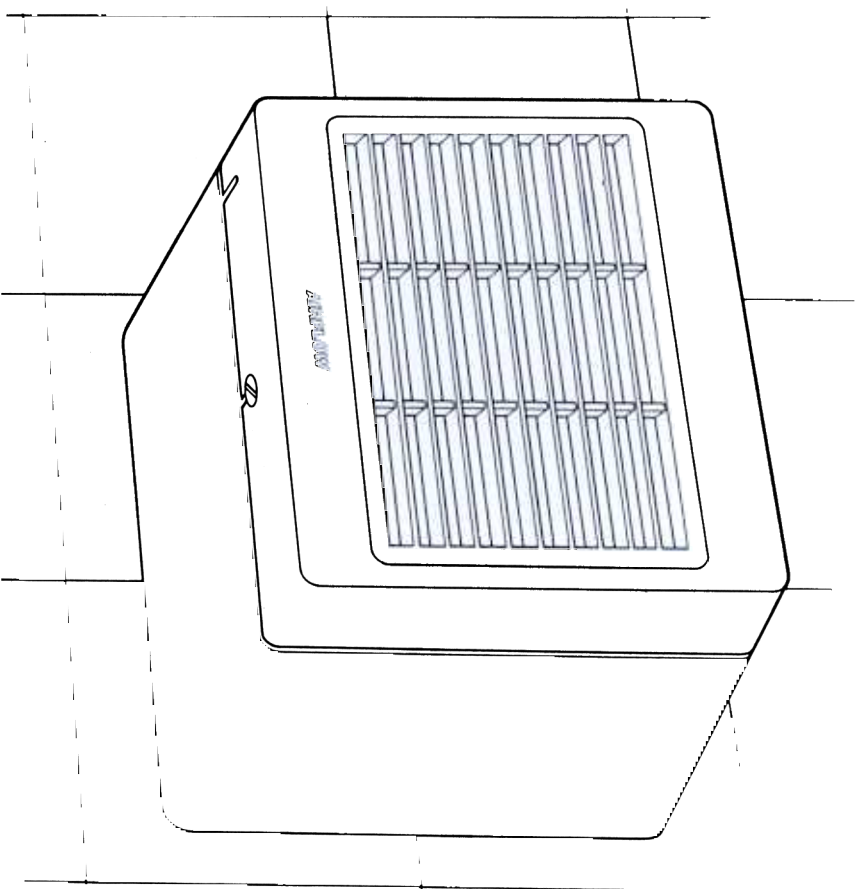

# Section 1: Options

	MODEL	APPLICATION	FEATURES	OPERATION BY
1.1	Loovent 01	For single toilets or bathrooms particularly those with no natural light or ventilation and with a volume of up to 34 cubic metres.	Integral timer runs for pre-set period	Room light or door switch
1.2	Loovent 02/2S	As 01 above but especially suited to hotel bathrooms where continuous ventilation is desirable.	Continuous low speed and high speed 'boost'	Room light for 'boost'
1.3	Loovent 03	For single toilets or bathrooms with natural light and with a volume of up to 34 cubic metres.	On or off as required	Integral pull switch
1.4	Loovent 06		Integral timer runs for pre-set period	Integral pull switch
1.5	Loovent L11	As 01 Loovent	As 01 Loovent	Integral sensor reacting to light
1.6	Humidivent H50	For single toilets, bathrooms or kitchens up to 34 cubic metres volume where automatic operation is desirable.	Humidistat for low speed operation high speed 'boost'	Integral pull switch for 'boost'
1.7	Humidivent H50N	As Humidivent H50	As Humidivent H50 but fitted with neon to indicate 'on'	As Humidivent H50
1.8	Humidivent H51	Combined toilet/shower or bathroom up to 34 cubic metres volume where automatic, triggered and manual operation are required.	Humidistat for low speed operation. High speed override by integral pull switch. Timer runs for pre-set period when triggered by light or door switch	Room light, door switch or integral pull switch
1.9	Humidivent H56	Combined toilet/shower or bathroom up to 34 cubic metres volume where automatic and manual operation are required.	Operation by Humidistat or by integral override pull switch giving 6 minutes run period. Adjustable fan speed	Integral pull switch

## Section 2: Positioning

**2.1** All models may be surface mounted on, or recessed in a wall or ceiling, or mounted in a window. They must not be sited where there is any possibility of direct liquid spray or where the normal air temperature may exceed 40°C.

**2.2** Loovens or Humidivents should not be used in air containing flammable gases or dust.

**2.3** It is particularly important that an adequate supply of fresh air is provided if the fan is to be fitted in a room with a gas burning appliance which is NOT of the balanced flue type.

**2.4** The position chosen should give the best flow of air through the whole room. Consider the position of doors, windows, curtains and blinds and sources of stale air, odours and condensation.

As a general rule the fan should be mounted as high as possible (see Fig. 1).

**2.5** The instructions in this booklet are given for walls of bricks, concrete block or other masonry. For other types of construction the method of fixing may have to be adapted.

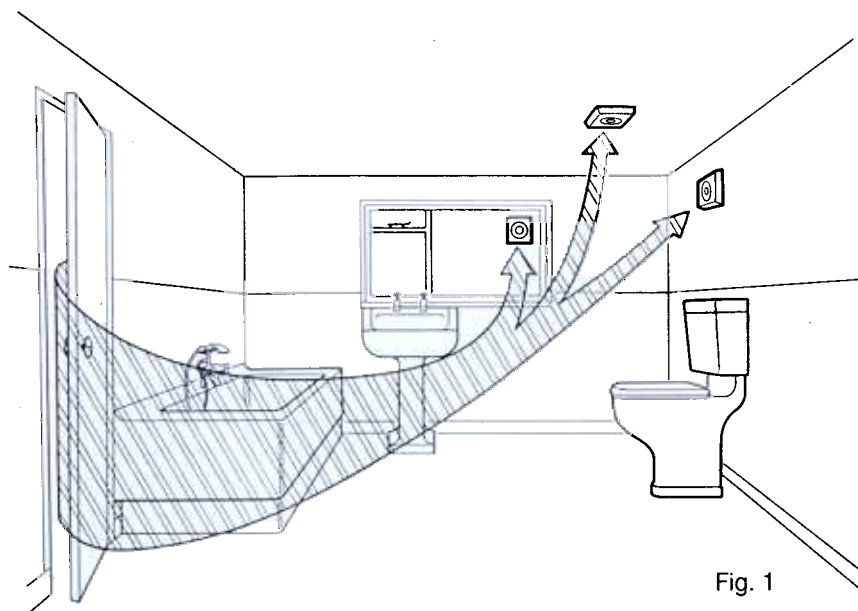

Fig. 1

## Section 3: First steps

**3.1** The carton contains an assembled fan, bezel and polystyrene case support. Unpack these items and check that they are undamaged. If damaged, do not use. Report any damage to supplier.

Before installation ensure that you have the model you require from the range

available. (See section 1). The model reference is marked on the carton, and on the front of the module.

**3.2** The following items are or may be required depending on the type of installation:

	ITEM	MODEL									
		01	02/2S	03	06	L11	H50	H50N	H51	H56	
3.2.1	4 core cable (3 cores + )	✓	✓	—	—	—	—	—	✓	—	
3.2.2	3 core cable (2 cores + )	✓	✓	✓	✓	✓	✓	✓	✓	✓	
3.2.3	2 core cable for door switch	✓	—	—	—	—	—	—	✓	—	
3.2.4	Switched, fused, connection unit	✓	✓	✓	✓	✓	✓	✓	✓	✓	
3.2.5	Door switch	✓	—	—	—	—	—	—	✓	—	
3.2.6	Outlet grille <b>or</b> roof cowl and weathering slate	✓	✓	✓	✓	✓	✓	✓	✓	✓	
3.2.7	110 mm od plastic pipe <b>or</b> flex tubing to suit 97 o.d.	✓	✓	✓	✓	✓	✓	✓	✓	✓	
3.2.8	Junction box	✓	✓	—	—	—	—	—	✓	—	
3.2.9	Window Kit	✓	✓	✓	✓	—	✓	✓	✓	✓	
3.2.10	Condensation trap	✓	✓	✓	✓	✓	✓	✓	✓	✓	

**3.3** No special tools are essential but the use of a 4½" core drill which may be obtained from your local hire shop will make the job easier.

**3.4** Please read the appropriate parts of these instructions before starting work.

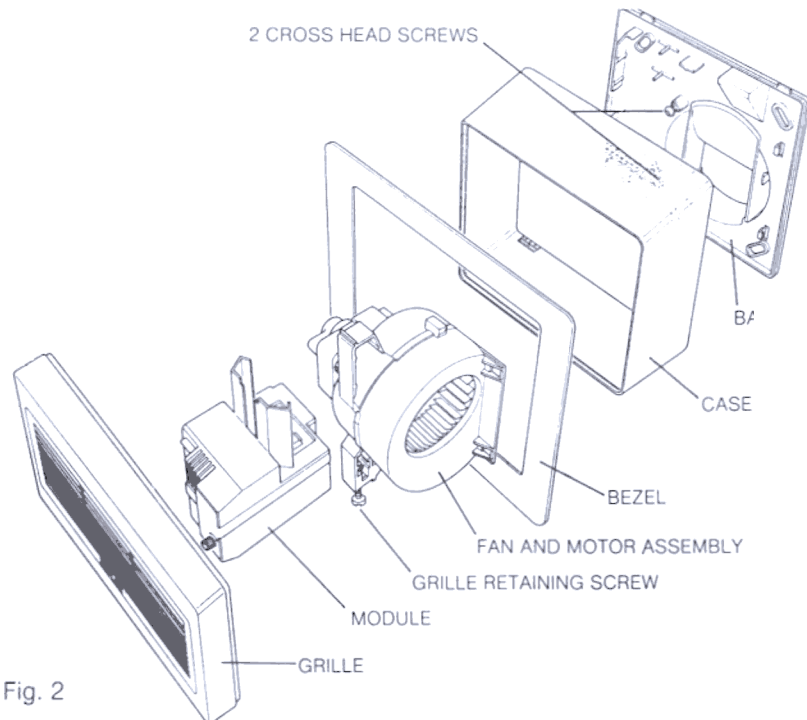

Fig. 2

# Section 4: Wiring arrangements

**4.1** All electrical installations must comply with IEE wiring regulations. It is a requirement of the IEE regulations that all appliances shall be installed via a switched, fused connection unit. All fans in the range must be earthed. It is recommended that the installation is carried out by a qualified electrician.

**4.2** The fan, switches or wiring must not be directly accessible to a person using a bath or a shower. If the fan unit is fitted in a bathroom the switched, fused connection unit must be mounted outside the room.

## 4.6 Wiring Diagrams

### 4.6.1 DIAGRAM 1. MODELS 01 AND H51 – DOOR SWITCH OPERATION.

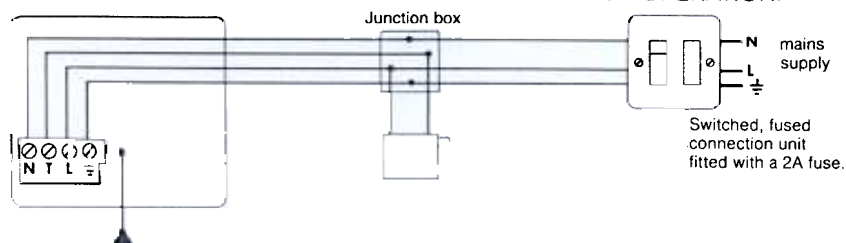

### 4.6.2 DIAGRAM 2. MODELS 01, 02/2S AND H51 – LIGHT SWITCH OPERATION.

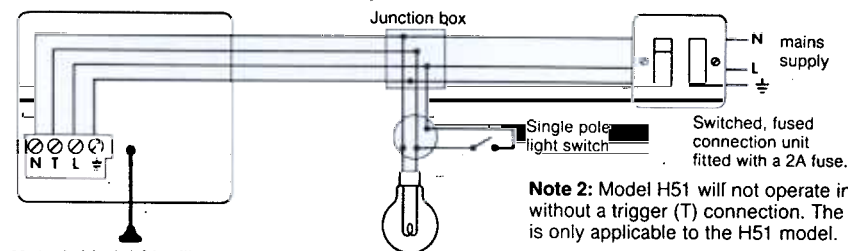

**Note 1:** Model 01 will not operate without a trigger (T) connection.

**Note 2:** Model H51 will not operate in its timed mode without a trigger (T) connection. The pull switch shown is only applicable to the H51 model.

**Note 3:** Model 02/2S will not operate at 'boost' without a trigger (T) connection.

### 4.6.3 DIAGRAM 3. MODELS 03, 06, L11, H50, H50N AND H56.

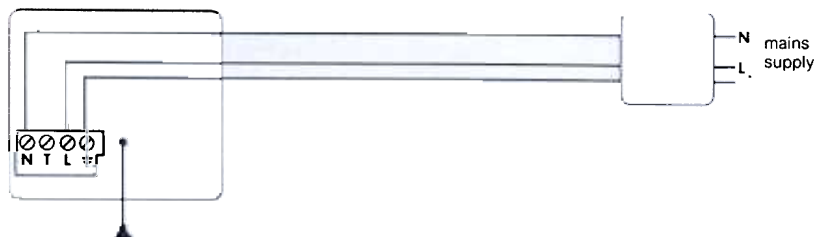

# Section 5: Installation on the wall surface

## Applies to all models

**5.1** Dismantle the unit by first undoing the slotted screw on the underside of the grille a few turns and removing the grille by pivoting it about its top edge. Remove the module by lifting and pulling it out. Release the fan and motor assembly by undoing the two cross-headed screws several turns and sliding the assembly to the right (see Fig. 2). To ease installation it is best to spring the backplate out of the case.

**5.2** Mark the positions and sizes of the holes for the exhaust and cable entry and the hole centres for fixing the backplate to the wall using the template provided, which must be broken out along the perforations of the carton insert. Carefully make a hole for the exhaust large enough to clear 110 mm o.d. plastic pipe.

**5.3** Cut a length of 110 mm o.d. plastic pipe to bridge the wall cavity. Grout into position to maintain the integrity of the cavity.

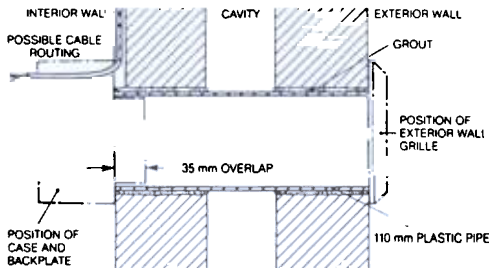

Fig. 3

**5.4** Install the electricity supply cables (see Section 4 and Fig 3) allowing 250 mm to protrude for making connections within the case.

**5.5** Drill and plug the four fixing holes for the backplate to accept 38 mm long No. 8 roundhead screws. Fit the backplate to the wall after feeding the cables through the entry hole. Retain with four screws, which should not be overtightened. Reassemble the case by aligning it with the backplate and sharply tapping opposite edges with the palm of the hand until it is securely latched (see Fig 4).

Make sure that the case and backplate is level. The slotted fixing holes allow for some adjustment.

Make the electrical connections to the terminal block, after releasing it from the backplate (see Section 4 and Fig 5).

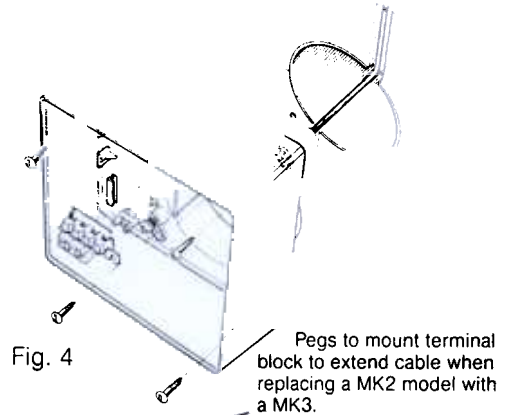

Fig. 4

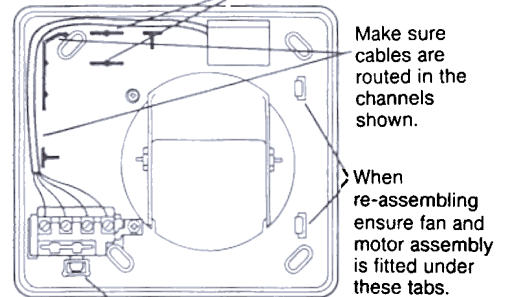

Fig. 5

To assist wiring, release terminal block with screwdriver blade inserted here.

**5.6** Re-fit the terminal block, fan and motor assembly, which must be inserted under the tabs on the backplate and be pulled to the left whilst tightening the fixing screws, followed by the module and grille. Do not overtighten the grille retaining screw.

**5.7** The external wall grille (available from Airflow) may now be fitted. Place it against the outside wall face centered over the duct outlet. Mark the fixing hole positions, drill and plug the wall and fix with 25 mm long No. 6 roundhead screws.



# Section 6: Installation within the wall

Applies to all models

**6.1** Dismantle the unit (see Section 5.1). For this installation it is best not to separate the case and backplate.

**6.2** Make an opening in the wall large enough to fit the case and backplate and to take the exhaust to the outside wall. Allow about 10 mm clearance all round the casing and pipe (see Fig. 6).

**6.3** Cut a length of 110 mm o.d. plastic pipe to fit over the exhaust spigot and reach to the outside wall. If a seal is important between the outlet spigot and the pipe, use 6 mm thick self adhesive foam tape around the spigot circumference.

The front face of the case should protrude by 4 to 6 mm from the wall surface if the bezel is to be used (see Fig. 7).

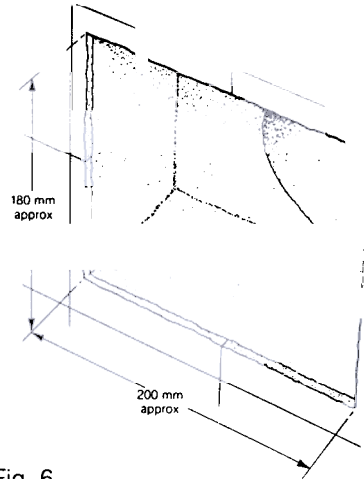

Fig. 6

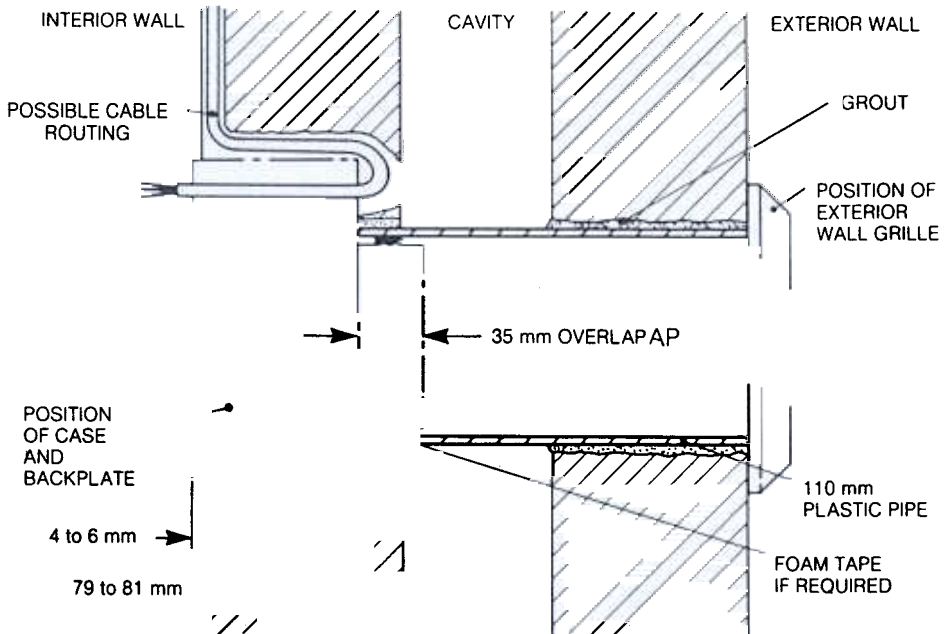

Fig. 7

**6.4** Install the electricity supply cables (see Section 4 and Fig. 7), allowing 250 mm to protrude for making connections within the case.

**6.5** Grout the casing and pipe in place making sure that the top edge of the casing is horizontal, the front protruding and that the tubing is flush with the outside. The pressure of the grouting material may cause the casing to bow, therefore it is recommended that the polystyrene support is used until the grout has set (see Fig. 8). Alternatively, check that the grille is a loose fit within the casing before the grout has set.

Fit the bezel by pushing over the casing up to the wall surface.

**6.6** When the grout has set, make the electrical connections to the terminal block after releasing it from the backplate. (See Section 4 and Fig. 9).

**6.7** Re-fit the terminal block fan and motor assembly, which must be inserted under the tabs on the backplate and be pulled to the left whilst tightening the fixing screws, followed by the module and grille. Do not overtighten the grille retaining screw.

**6.8** Fit the external wall grille (see Section 5.7).

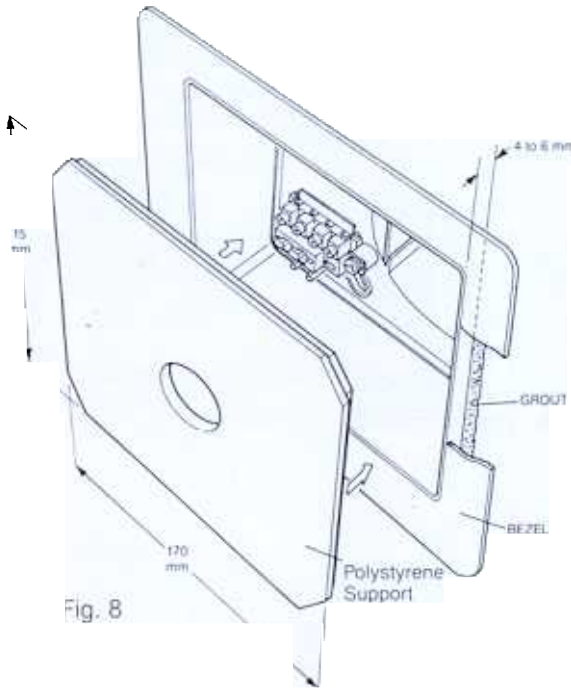

Fig. 8

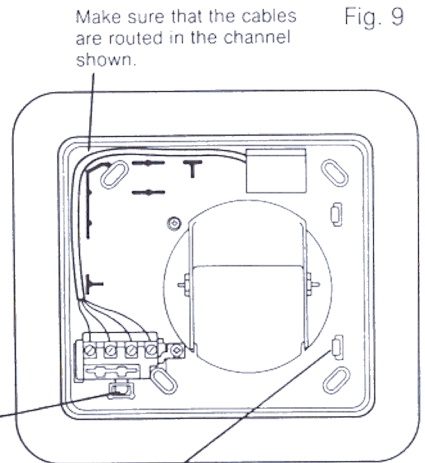

Fig. 9

When re-assembling ensure that the fan and motor assembly is fitted under these tabs.



# Section 7: Installation on the ceiling surface

## Applies to all models

**7.1** Make a support to fit between the joists as shown (see Fig. 10). Mark the positions and sizes of the holes for the exhaust and cable entry and the hole centres for fixing the backplate using the template provided, which must be broken out along the perforations of the carton insert.

Cut holes for the exhaust and cable entry. Make sure when cutting the exhaust holes, that there is sufficient clearance for the type of ducting to be fitted.

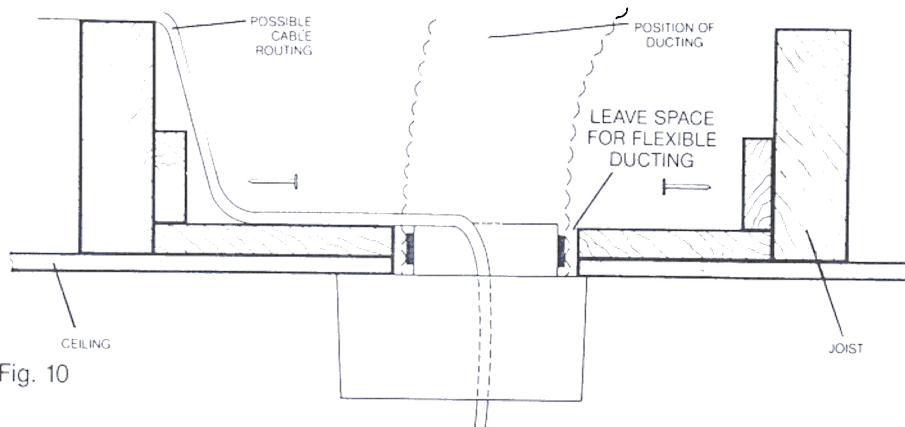

**7.2** Mark and cut out ceiling holes making sure that they align correctly with holes in the support.

**7.3** Install the electricity supply cables (see Section 4). Allow a minimum of 250 mm of cable to protrude beyond the ceiling for making connections within the case.

**7.4** Dismantle the unit (see Section 5.1 and Fig. 2).

**7.5** Feed the cables through the entry hole in the backplate and fix the case and backplate to the support using four 38 mm No. 8 roundhead screws, which should not be overtightened. Reassemble the case by aligning it with the backplate and sharply tapping opposite edges with the palm of the hand until it is securely latched (see Fig. 4).

The slotted fixing holes allow for some adjustment of the angular position of the case and backplate.

**7.6** Make the electrical connections to the terminal block after releasing it from the backplate (see Section 4 and Fig. 5).

**7.7** Refit the terminal block, fan and motor assembly, which must be inserted under the tabs on the backplate and be pulled to the left whilst tightening the fixing screws, followed by the module and grille. Do not overtighten the grille retaining screw. If the unit is fitted with a pull cord, route the cord through the grille aperture (see Fig. 11).

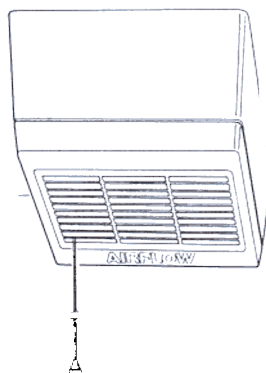

**7.8** Install ducting from the exhaust spigot either through the roof using a weathering slate and roof cowl, or under the eaves using an outlet grille (both available from Airflow), (see Fig. 12).

When venting vertically through the roof void there may be problems with condensation

due to moist warm air coming into contact with the cold surface of the exhaust duct. This condensation may drip down into the fan unless the pipe is lagged, twin walled insulated pipe is used or a moisture trap fitted as near to the unit as possible.

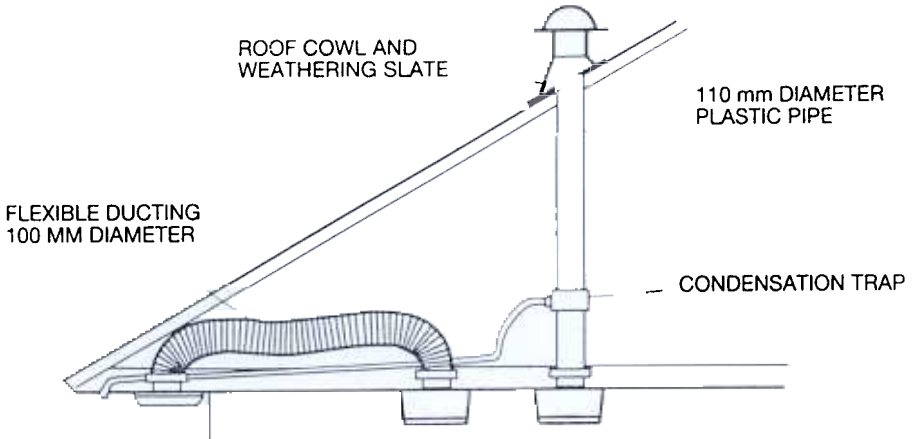

Fig. 12 ALTERNATIVE METHODS OF VENTING THROUGH ROOF

## Section 8: Installation within the ceiling

Applies to all models

**8.1** Make a support to fit between the joists as shown (see Fig. 13). Mark the positions and sizes of the holes for the exhaust and cable entry and hole centres for fixing the backplate using the template provided, which must be broken out along the perforations of

the carton insert.

Cut holes for the exhaust and cable entry. Make sure when cutting the exhaust hole, that there is sufficient clearance for the type of ducting to be fitted.

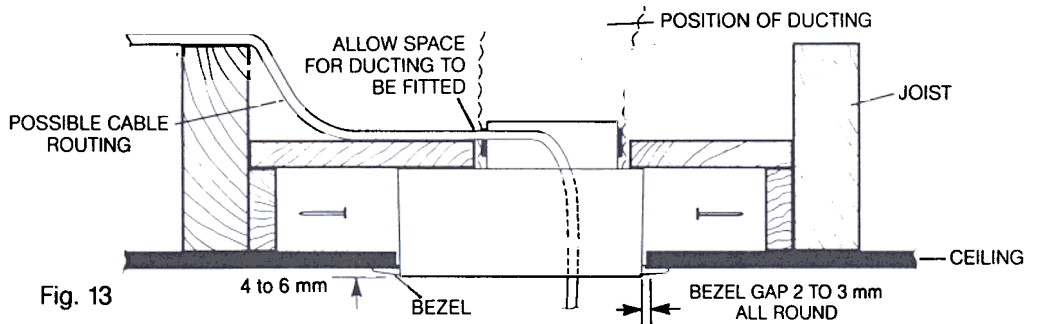

Fig. 13

- 8.2** Mark and cut out ceiling holes making sure that they align correctly with holes in the support.
- 8.3** Install the electricity supply cables (see Section 4). Allow a minimum of 250 mm of cable to protrude for making connections within the case.
- 8.4** Dismantle the unit (see Section 5.1 and Fig. 2). For this installation it is best not to separate the case and backplate.
- 8.5** Fit the cable through the entry hole in the backplate and fix the case and backplate to the support using four 38 mm No. 8 roundhead screws, which should not be overtightened as this may result in the backplate becoming distorted. Note that the slotted fixing holes in the backplate allow for some adjustment.

**8.6** Make the electrical connections to the terminal block after releasing it from the backplate (see Section 4 and Fig. 5).

**8.7** Refit the terminal block, fan case and motor assembly which must be inserted under the tabs on the backplate and be pulled to the left whilst tightening the fixing screws, followed by the module and grille. Do not overtighten the grille retaining screw.

If the unit is fitted with a pull cord route the cord through the grille aperture (see Fig. 11).

Fit the bezel by pushing it over the casing up to the ceiling surface.

**8.8** Install ducting in the roof void (see Section 7.8 and Fig. 12).

## Section 9: Installation in a window

Applies to 01, 03, 06, H50, H50N, H51 and H56 models

**Note.** A window kit, available from Airflow, is essential to complete this installation.

**9.1** It is recommended that the glass used for mounting the Loovent or Humidivent is a minimum of 4 mm thick (32oz). For position

and size of hole in window see Fig 14.

If the fan is to be mounted in hermetically sealed double glazing it will be necessary to obtain a window from a glazing manufacturer which is properly supported between, and sealed around, the hole for the fan.

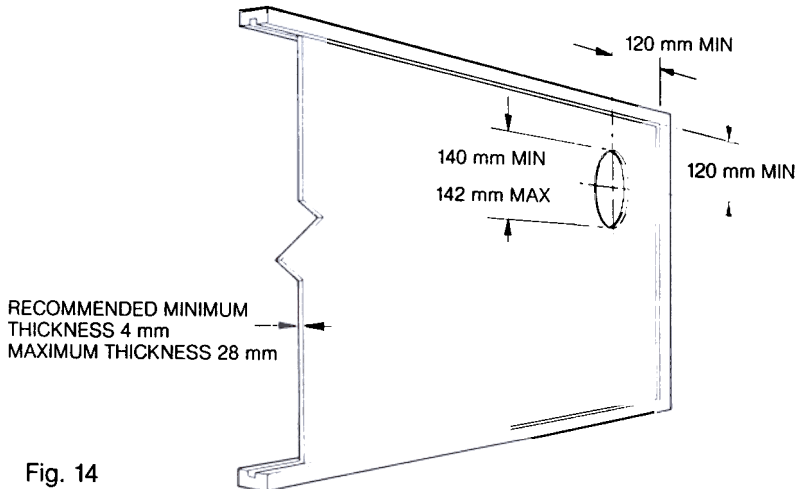

Fig. 14

**9.2** Dismantle the Loovent or Humidivent (see section 5.1 and Fig. 2). For window installation, do not separate the case and backplate.

**9.3** Drill a hole in the fan case for the mains cable and knock out the holes for fixing to the window kit (see Fig. 15).

**9.4** Remove the backdraught flap from the backplate (see Figs. 17 and 18) as flaps are provided in the outer cover.

**9.5** To reduce the load on the glass during the final assembly into the window, take the two 4 mm X 40 mm long screws from the fixing pack and assemble them a few turns and release them from the holes in the outer cover.

**9.6** Cut the sealing strip provided to length to fit around the edge of the outer cover and fit it with the long lip on the outside and the joint at the bottom.

**9.7** Hold the case and backplate over the window aperture and the outer cover on the outside. Fit and tighten the 4 mm X 40 mm long screws sufficiently to create a seal on the glass and secure the fan in position. Do not overtighten.

**9.8** Fit the mains cable through the hole in the fan case and make connections to the terminal block after releasing it from the backplate (see Section 4 and Fig. 5).

**9.9** Refit the terminal block, fan and motor assembly, which must be inserted under the tabs on the backplate and be pulled to the left whilst tightening the fixing screws, followed by the module and grille. Do not overtighten the grille retaining screw.

# Section 10: Testing

**10.1** When the installation is complete, switch on the electricity supply.

## **10.1.1 Model 01**

Operate the door or light switch as appropriate to check that the fan starts and runs on for a pre-set period after the door is closed or the light switched off. See Section 10.4 for timer adjustment.

## **10.1.2 Model 02/2S**

The fan should operate immediately on low speed, changing to high speed on operation of the light switch. See Section 10.6 for adjustment of motor 'low speed'.

## **10.1.3 Model 03**

Check that the fan operates when the cord is pulled and switches off when it is pulled again.

## **10.1.4 Model 06**

Pull cord down for at least 1 second to allow the timer to become activated. Check that the fan starts and runs on for a pre-set period. See Section 10.4 for timer adjustment.

## **10.1.5 Model L11**

Operate the light switch to check that the fan starts and runs on for a pre-set period after the light is switched off. See Section 10.4 for timer adjustment.

## **10.1.6 Model H50**

The fan may operate immediately on low speed subject to the humidity level in the room being greater than the humidity setting of the humidistat.

Pull the cord to initiate the high speed 'Boost' condition. Pull again to revert to humidistat control which is overridden when on 'Boost'. Note that the fan will run on for about 6 minutes after the humidity level in the room falls below the humidity setting. See Section 10.5 for humidity setting adjustment.

## **10.1.7 Model H50N**

The fan operation is exactly as model H50 above except that a neon is illuminated to indicate when the fan is running on low speed or 'Boost'. See Section 10.5 for humidity setting adjustment.

## **10.1.8 Model H51**

This model may operate in various modes as follows:

**10.1.8.1** It may operate immediately on low speed subject to the humidity level in the room being greater than the humidity setting of the humidistat. Note that the fan will run on for about 6 minutes after the humidity level in the room falls below the humidity setting.

**10.1.8.2** By pulling the cord to initiate the high speed 'Boost' condition. Pull again to revert to humidistat control.

**10.1.8.3** Operate the door or light switch as appropriate to check that the fan starts on high speed 'Boost' and runs for a pre-set period after the door is closed or the light switched off.

**10.1.8.4** See Section 10.4 for timer adjustment. See Section 10.5 for humidity setting adjustment.

## **10.1.9 Model H56**

This model may operate in various modes as follows:

**10.1.9.1** It may operate immediately subject to the humidity level in the room being greater than the humidity setting of the humidistat. The fan will run on for about 6 minutes after the humidity level in the room falls below the humidity setting.

**10.1.9.2** Pull the momentary pull cord for about 1 second to activate the timer. Check that the fan starts and runs on for about 6 minutes. At the end of this time, the fan will revert to humidistat control.

**10.1.9.3** See Section 10.5 for humidity setting adjustment. See Section 10.7 for adjustment of motor speed.

**10.2** If any model fails to operate correctly disconnect it from the electricity supply and check that all electrical connections have been properly made. Check the fuse.

**10.3** Switch on the electricity supply and test again. If the fan still fails to operate correctly do not tamper with it. Contact the Airflow Service Department on High Wycombe (01494) 525252.

**10.4** Timer adjustment models 01, 06, L11 and H51.

**10.4.1** Disconnect the fan from the electricity supply.

**10.4.2** Remove the front grille.

**10.4.3** Turn the adjusting knob clockwise to increase and anti-clockwise to decrease the operating period (see Fig. 16). The timer is factory set to operate for about 25 minutes and may be adjusted from a minimum of about 5 minutes to a maximum of about 45 minutes.

**10.4.4** Re-assemble the fan, switch on the electricity supply and re-test to Section 10.1.1 (model 01), Section 10.1.4 (model 06), Section 10.1.5 (model L11) or Section 10.1.8 (model H51).

**10.5** Humidity setting adjustment – Models H50, H50N, H51 and H56.

The humidistat has a range of 40 to 95% relative humidity, but is factory set to 70% RH. It can be adjusted to be more sensitive (switches at lower RH) or less sensitive (switches at higher RH) to suit the user. To adjust sensitivity.

**10.5.1** Disconnect the fan from the electricity supply.

**10.5.2** Remove the front grille.

**10.5.3** Turn the adjuster knob clockwise to increase, and anti-clockwise to decrease sensitivity (see Fig. 16).

**10.5.4** Re-assemble the fan, switch on the electricity supply and re-test to Section 10.1.6 (model H50), 10.1.7 (model H50N), 10.1.8 (model H51) or 10.1.9 (model H56).

Modules are fitted to all models. Each is identified by a label on the front face and the variants are shown below: The module is shown in Fig. 2



Fig. 16



**10.6 Motor low speed adjustment – model 02/2S.**

This model normally operates on low speed unless overridden, so provision is made to adjust the low speed to suit the user.

Note that low fan speed reduces noise levels but also reduces the volume of air moved.

To adjust the speed:

**10.6.1** Disconnect the fan from the electricity supply.

**10.6.2** Remove the front grille.

**10.6.3** Turn the adjuster knob clockwise to increase and anti-clockwise to decrease speed (see Fig. 16). If it is intended to reduce the speed below the factory setting, it is recommended that the backdraught flap be removed (see Figs. 17 and 18).

**10.6.4** Re-assemble the fan, switch on the electricity supply and re-test to Section 10.1.2 (model 02/2S).

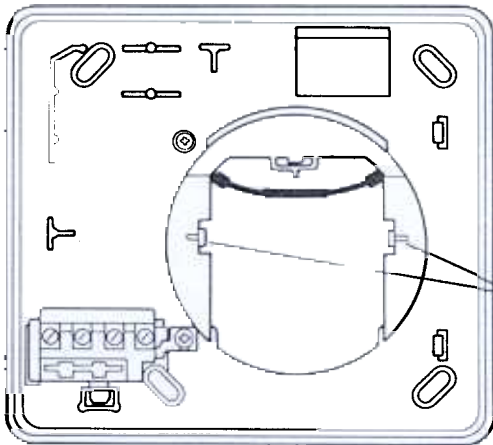

Fig. 18

**10.7 Motor speed adjustment – model H56.**  
The motor speed may be adjusted to suit the user. Note that lower fan speed reduces noise levels, but also reduces the volume of air moved.

To adjust the speed:

**10.7.1** Disconnect the fan from the electricity supply.

**10.7.2** Remove the front grille.

**10.7.3** Turn the adjuster knob clockwise to increase and anti-clockwise to decrease speed (see Fig. 16).

**10.7.4** Re-assemble the fan, switch on the electricity supply and re-test to Section 10.1.9

**10.8** After completion of the installation, adjustment and testing, pass these instructions onto the user of the premises.

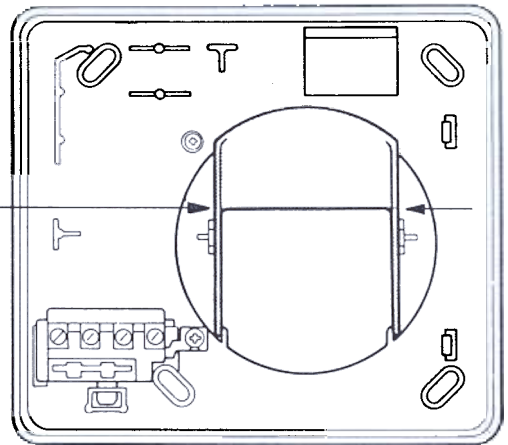

Fig. 17

# Section 11: User Information

## 11.1 Guarantee

Airflow products are built to the highest quality standards and should provide you with years of reliable service. In addition to all your legal rights as a purchaser your Airflow fan is covered by a two years' no quibble guarantee from the date of manufacture.

If a fault occurs after installation and providing that the fan has been installed according to our recommendations it will be exchanged.

To obtain a replacement fan contact your installer or supplier.

Please keep this instruction book in a safe place and pass it on to the new owner if the property changes hands.

## 11.2 Operation

If your Airflow fan fails to work correctly, contact the installer or failing that, contact the Airflow Service Department on High

Wycombe (01494) 525252

## 11.3 Safety

When installed and used according to these instructions this Airflow range of fans is completely safe. The materials employed do not constitute a hazard. The black plastic parts enclosing the timer etc, are made from flame retardant material.

## 11.4 Cleaning

The exterior of a fan may be cleaned with a dry cloth.

The interior of the fan should also be cleaned occasionally. First disconnect from the electricity supply and then dismantle the fan (see Section 5.1). The grille may be washed though the module, motor and fan assembly **MUST NOT** be immersed in water. If necessary the impeller blades may be cleaned with a soft brush.

# AIRFLOW™

QUALITY ASSURED TO ISO 9001

Airflow Developments Limited, Lancaster Road,  
Cressex Business Park, High Wycombe,  
Buckinghamshire HP12 3QP, England  
Telephone: (01494) 525252/443821  
Facsimile: (01494) 461073  
E-mail: [info@airflow.co.uk](mailto:info@airflow.co.uk)  
WWW: <http://www.airflow.co.uk>

Airflow Lufttechnik GmbH, Postfach 1208, D-53349 Rheinbach, Germany.  
Telefon: 02226/9205-0. Telefax: 02226/9205-11. eMail: [airflow@t-online.de](mailto:airflow@t-online.de)

Airflow Lufttechnik GmbH, o.s. Praha, Hostynska 520, 10800 Praha 10 - Malesice, Czech republic.  
Telefon a fax: 02-77 22 30

Airflow Technical Products Inc, 23 Railroad Avenue, Netcong, N.J. 07857 USA  
Telephone: 201-691-4825. Fax: 201-691-4703.