

Dimplex

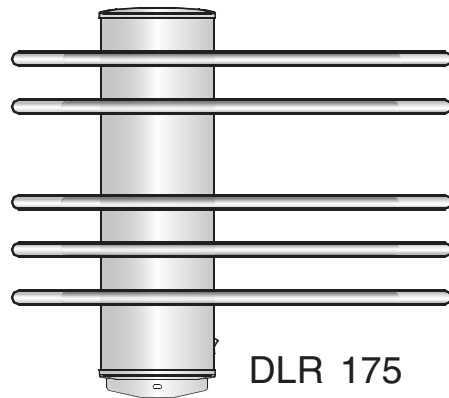

DLR 175

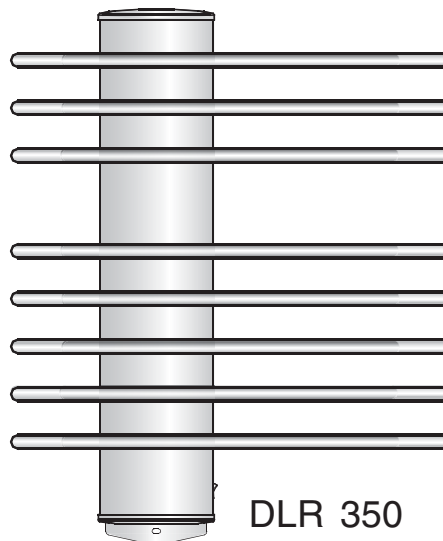

DLR 350



1

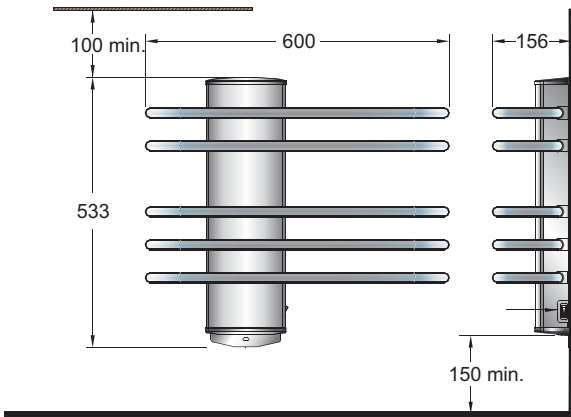

DLR 175

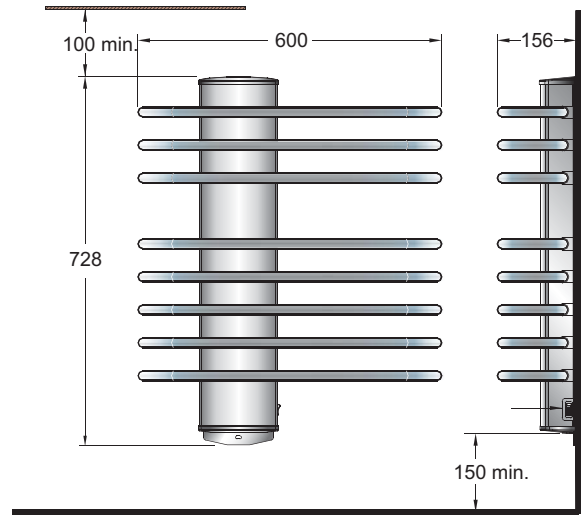

DLR 300

2

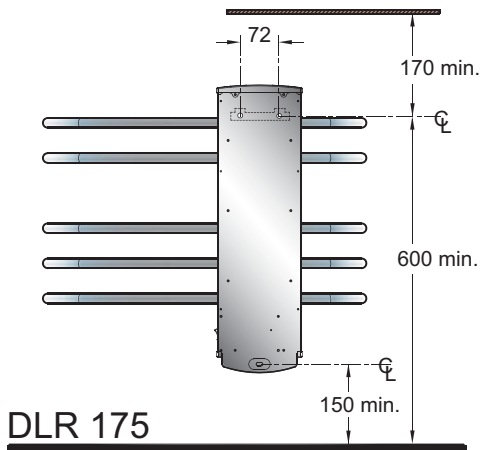

DLR 175

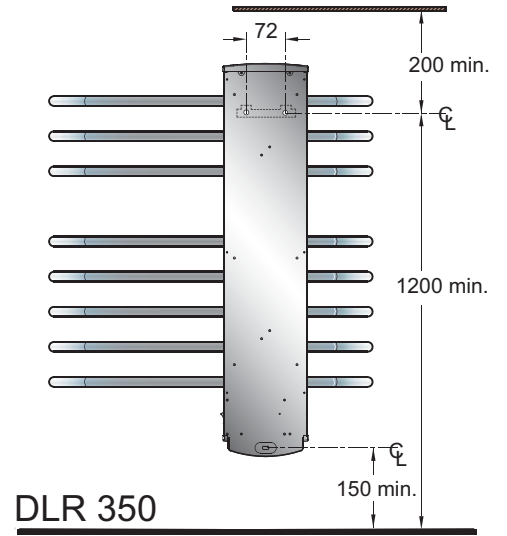

DLR 350

3

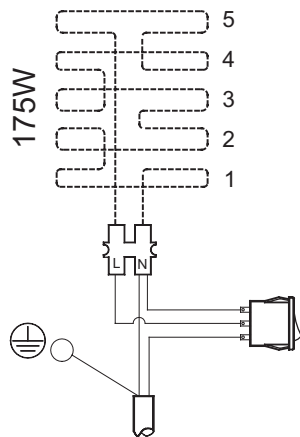

DLR 175

4

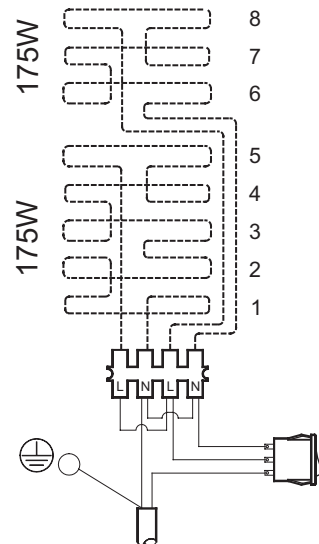

DLR 350

Installation and Operating Instructions

Ladder Towel Rails

Models : DLR 175 and DLR 175C
DLR 350 and DLR 350C



IMPORTANT: THESE INSTRUCTIONS SHOULD BE READ CAREFULLY AND RETAINED FOR FUTURE REFERENCE

Models	Specification
DLR 175	175W, 5 Rails, White
DLR 175C	175W, 5 Rails, Chrome
DLR 350	350W, 8 Rails, White
DLR 350C	350W, 8 Rails, Chrome

IMPORTANT SAFETY ADVICE

WARNING –THE SURFACE OF THESE TOWEL RAILS CAN BE HOT. The surface temperatures are within the requirements of EN60335-2-43, the European standard covering the safety requirements of electrically heated towel rails. In order to be effective the towel rail will get hot, however momentary contact with any part of it should not cause injury.

CAUTION – Aged or infirm persons and young children should not be left unsupervised in the vicinity of the towel rail. Precautions should be taken to ensure that prolonged contact with the towel rail cannot occur. Particular care should be taken in confined areas where accidental prolonged contact with the rail could be more likely to occur.

IMPORTANT – If the towel rail is to be installed in a place used by the public, a warning notice should be placed adjacent to the rail advising that the surface can be hot.

If the supply cord is damaged it must be replaced by the manufacturer or service agent or a similarly qualified person in order to avoid a hazard.

General

The DLR towel rail is designed to provide an all year round service for airing towels and articles of clothing. It is not intended to provide a sole heating service, but the larger model will take the chill off a normal size bathroom or toilet. Your rail will be in one of two sizes and will have either silver chromium plated or white stove-enamel finish.

No routine maintenance is necessary apart from occasional cleaning. Both models are splashproof to IPX4 standard.

Electrical connection

WARNING – THIS APPLIANCE MUST BE EARTHED

The electrical installation of this towel rail must be carried out by a competent electrician in accordance with the current I.E.E Regulations for Electrical Equipment. The towel rail is suitable for use on an **A.C.**~ electrical supply. Before installation check that the supply voltage corresponds with that marked on the rail.

IMPORTANT - The wires in the mains lead are coloured in accordance with the following code:

GREEN and YELLOW	-	EARTH
BLUE	-	NEUTRAL
BROWN	-	LIVE

As the colours of the wires in the mains lead of this appliance may not correspond with the coloured markings identifying the terminals in your fixed socket outlet, proceed as follows:

The wire which is coloured **GREEN** and **YELLOW** must be connected to the terminal in the fixed socket outlet which is marked with the letter **E** or by the earth symbol  or coloured green or green and yellow.

The wire which is coloured **BLUE** must be connected to the terminal which is marked with the letter **N** or coloured black

The wire which is coloured **BROWN** must be connected to the terminal which is marked with the letter **L** or coloured red.

This appliance must only be used on A.C. mains supply of 230/240 Volts~.

Installation

IMPORTANT – Protect the electrical connection whilst handling the towel rail.

Operation (Electrical)

The towel rail may be switched on and off by means of a switch located on the right hand side of the central panel. Heat will be distributed along each of the rails and a smaller amount from the central panel.

Some variation in the temperature across the surface of the rail is also normal. When the appliance is covered the heating pattern of the rails may alter slightly.

Wall mounting

The towel rail must be permanently fixed to the wall using the wall mounting bracket and screws supplied. The rail must be mounted vertically as shown observing the minimum clearances stated (see **Fig. 1**).

The accessory pack contains a wall mounting bracket, three Ø6mm screws and wall plugs, which will secure the towel rail to the wall.

Place the wall mounting bracket against the wall as shown. (see **Fig. 2**). Ensure the bracket is horizontal, mark the hole's positions and drill and plug wall to suit. Then screw two of the screws supplied into the wall plugs.

Hang the towel rail on to the bracket, then mark the hole position for the bottom screw, drill and plug wall to suit.

Wiring

- see Wiring Diagrams : for DLR175 see **Fig. 3**, and DLR350 see **Fig. 4**.

Drying and Airing Towels

It is recommended that for efficient drying, no more than two layers of towels or similar fabric should be draped over each rail. Items should be placed evenly over the whole surface of the rail where possible.

It is not advisable to leave very damp towels or clothes on the towel rail when **not** switched on, as this may in time, affect the product finish.

The rail, although hot to the touch is not hot enough to scorch or burn fabrics. However, soap and detergents remaining in articles after washing can cause discoloration. Therefore care should be taken to thoroughly rinse articles before airing.

Cleaning

The finish on your towel rail can be maintained by occasionally wiping over with a damp cloth and lightly finishing with a soft dry cloth. This should only be carried out when the rail is cold. **Do not** use abrasive cleaning powders as this could damage the surface finish.

After Sales Service

Your product is guaranteed for one year from the date of purchase.

Within this period, we undertake to repair or exchange this product free of charge provided it has been installed and operated in accordance with these instructions.

Your rights under this guarantee are additional to your statutory rights, which in turn are not affected by this guarantee.

Should you require after sales service you should contact our customer services help desk on 0870 727 0101. It would assist us if you can quote the model number, series, date of purchase, and nature of the fault at the time of your call. The customer services help desk will also be able to advise you should you need to purchase any spares.

Please do not return a faulty product to us in the first instance as this may result in loss or damage and delay in providing you with a satisfactory service.

Please retain your receipt as proof of purchase.

Glen Dimplex UK Limited
Millbrook House
Grange Drive
Hedge End
Southampton
Hampshire. SO30 2DF

UK customer help line (8.00AM – 6.00PM Mon-Fri; 8.30AM-1.00PM Sat)

Customer Services:	Tel.	0870 7270101
	Fax.	0870 7270102
	e-mail	customer.services@glendimplex.com
Republic of Ireland	Tel.	01 8424833

[c] Glen Dimplex UK Limited

All rights reserved. Material contained in this publication may not be reproduced in whole or in part, without prior permission in writing of Glen Dimplex UK Limited.