

XL RANGE

this product information has been extracted from

theheatingbook



Tel: Customer Services: 0870 727 0101

Fax: Customer Services: 0870 727 0102

Email: customer.services@glendimplex.com

Website: www.dimplex.co.uk

BUILDING
REGULATIONS
PART L COMPLIANT



Model XLS12



Storage heater with shelf

Slimline storage heaters with manual and automatic input controls

the XL and XLS storage heater ranges

The UK's slimmest and most popular storage heaters offer performance, economy, ultra slim design and maintenance free reliability.

The XL and XLS ranges are suitable for a wide range of locations in both domestic and commercial applications. The heating level of XL range is adjusted by means of a variable input controls, which the occupant sets in line with the changing weather conditions.

The automatic XLS range offers improved comfort, economy and ease of use, employing a sophisticated automatic charging system which ensures the level of charge is adjusted to compensate for changing weather conditions without the need for user intervention. At the heart of this system is the patented Twin Sensor™*, which allow compatibility with all off peak tariffs. This meets the requirements of Building Regulations Part L1, which requires all electric storage heaters installed in new buildings to be fitted with automatic charge controls.

XL/XLS RANGES FEATURE

- Less than 150mm (6" deep).
- Smooth curved styling
- XL range features manually adjustable charge regulator to control the amount of heat stored during the charge period.
- XLS range features automatic charge regulator, which automatically adjusts the level of input charge to compensate for changing weather conditions without user intervention.
- Running cost savings of up to 15% can be achieved using automatic controller compared to manual static storage heaters.
- Room temperature boost control increases heat output when required and may be used automatically or manually.
- Easy to use controls, out of sight of young children.
- Frontal grille for efficient heat distribution.
- Secure wall fixings for safety.
- Feet may be fitted under carpet or on top of a suitable floor covering.
- Matches the PLX range of panel heaters
- Compatible with all off peak tariffs.
- See page 38 for accessories.

* UK Patent No: GB2265454 † XLS models.

XL MANUAL / XLS AUTOMATIC STORAGE HEATERS

CONSTRUCTION DETAILS

Galvanised finish sheet steel base, mounted on steel feet, supporting double skin front and outer panels. One piece front panel/grille assembly and front inner skin remove for brick loading.

INTERNAL DETAILS

1. STORAGE CORE

Material: High density bonded magnetite bricks.

2. HEATING ELEMENT

Type: Incoloy sheathed in units of 850W.

3. THERMAL INSULATION

Type (a) Front and Rear Panels – microporous silica.

Type (b) Top and Ends – resin free mineral wool

Type (c) Base – calcium silicate slab.

4. SUPPLY CONNECTION

Located at front right hand end of base – accessible by removal of front panel assembly. Hidden cable support straps at rear of heater allow neat supply cable connection from either side of heater.

5. ASSEMBLY

Remove front panel assembly then front inner skin. Remove internal packing containing elements, position rear layer of bricks, heating elements, and front layer of bricks.

CONTROLS

The control knobs are positioned on the sloping rear top panel of the heater, and are therefore out of sight of young children. The knobs incorporate a cross bar and raised pointer for ease of operation, and a simple setting guide is printed on the adjacent wall spacer.

1. CHARGE CONTROLLER – XL

Type: Hydraulic, adjustable from zero charge to fully charged condition

2. CHARGE CONTROLLER – XLS

Type: Hydraulic close differential room temperature sensing thermostat with linked internal and external sensors.

Dimplex Twin Sensor™: This patented feature offers the most accurate charge control of any automatic storage heater; by using two independent but interlinked sensors. Independent sensors are vital due to the large difference between the room temperature and the temperature of the heater's core. One sensor is situated on the outside of the heater case and the other above the storage core.

3. THERMAL SAFETY DEVICE

Type: Bi-metal – manual reset.

4. DAMPER CONTROL

Type: Bi-metal strip, selection variable from early to late or zero boost.

PACKING

1. CASE ASSEMBLY

Containing assembled heater case and heating elements. Packed in single carton.

XL12/XLS12 Model – approx. weight 20kg.

XL18/XLS18 Model – approx. weight 26kg.

XL24/XLS24 Model – approx. weight 32kg.

2. STORAGE BRICKS

Supplied in packs of 2. Approx weight of brick 7.5kg each.

FINISH

Front panel, sides and top panel – Willow White; rear heat shield, wall spacer and grille – contrasting Birch Grey.

SHELF

An attractive shelf is available in 3 lengths. (See page 30 for photograph).

ACCESSORIES

Please refer to page 38 for details of optional accessories.

MODEL	DIMENSION A	NO. OF SLOTS
XL12/XLS12	542mm	4
XL18/XLS18	770mm	5
XL24/XLS24	998mm	6

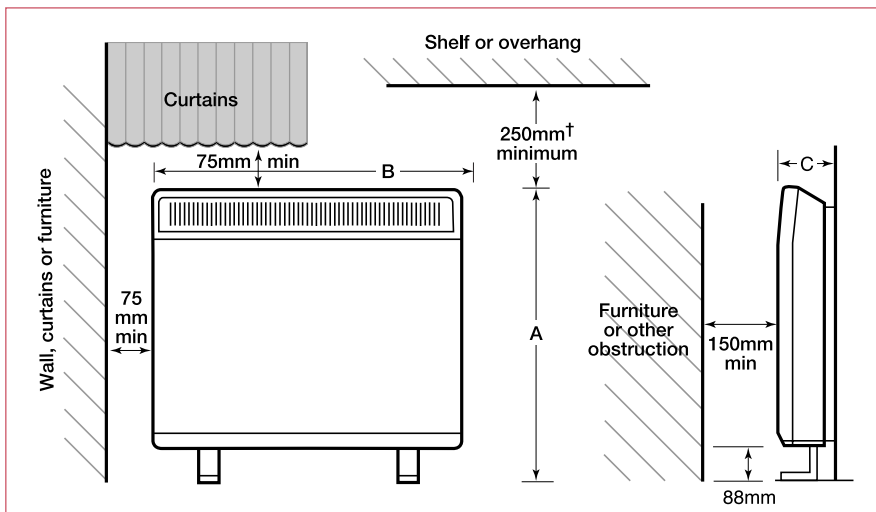
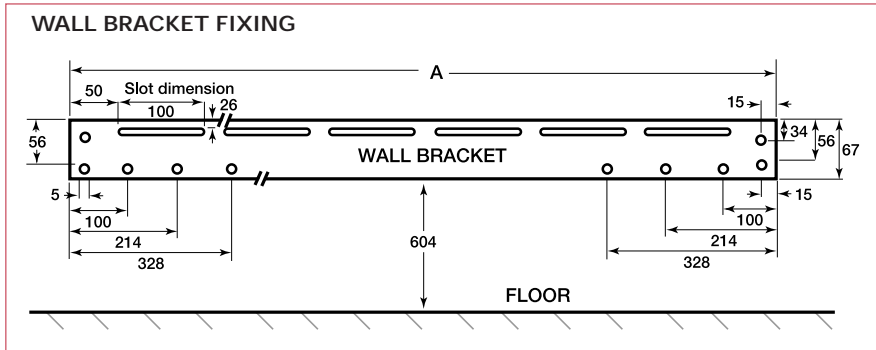

†When using Dimplex shelves a clearance of 150mm must be maintained.

The wall fixing arrangement is adjustable to accommodate for skirtings up to 150mm high and 25mm deep.

MODEL	XL12/XLS12	XL18/XLS18	XL24/XLS24
PERFORMANCE			
INPUT RATING	1.70kW	2.55kW	3.4kW
CHARGE ACCEPTANCE (7HR CONTINUOUS)	11.9kWh	17.85kWh	23.8kWh
DIMENSIONS			
HEIGHT (A)	706mm	706mm	706mm
WIDTH (B)	565mm	793mm	1021mm
DEPTH (C)	146mm	146mm	146mm
WEIGHT	76kg	109kg	144kg
SHELF MODEL NO.	SHE12	SHE18	SHE24

After Sales Service

After sales service if required is absolutely no problem with Dimplex – we have a network of appointed Service Agents spread throughout the Country who are qualified and trained to repair or service any of our appliances. A list of Service Agents is available on request.

Bathrooms

Any electrical appliances installed in a bathroom should be fitted by a competent electrician in accordance with the current I.E.E. Regulations.

Portable heaters are NOT suitable for use in a bathroom.

Unless otherwise specified in this brochure, heaters that can be permanently fixed have to be so mounted that any controls cannot be reached by a person using a bath or shower. This restriction does not apply to Dimplex heated towel rails, which do not have controls.

Safety

Dimplex products are designed to comply with EN60335 the British Standard covering the safety requirements of electric heating appliances, and momentary contact with any part of the heater should not cause injury. However, in order to be effective, heaters or towel rails of any type do get hot especially (if applicable) around the air outlet grille. Therefore if aged or infirm persons, or young children, are likely to be left unsupervised in the vicinity of a heater we advise that precautions should be taken. We recommend that a guard is fitted around the heater, as is normal with many types of heating appliance in similar circumstances, to ensure contact with the heater is avoided and objects cannot be inserted into the product.

(Please see page 38 for details of accessory guards.)

Heating appliances should never be covered or positioned where objects may fall onto them.

Specifications

Dimplex policy is one of continuous improvement; the Company therefore reserves the right to alter specifications without notice. Although every care has been taken in the reproduction of product finishes in this brochure, the colour photographs should be taken only as a guide. The information contained in this brochure is correct at the time of printing. You are advised to consult your Dealer before purchasing.

Plugs

All portable appliances are supplied with a fitted plug.

British Electrotechnical Approvals Board BEAB Approved

The mark of the British Electrotechnical Approvals Board signifies that the appliance bearing it has been produced to the stringent safety requirements for domestic electrical appliances as laid down in EN60335.



CE Mark

Products carrying the CE mark comply with European safety standards and the European Standard for electro-magnetic compatibility.



Installation Guidance

This brochure is designed to assist you with your choice of Dimplex products and it is not intended as an installation guide.

For safety, products should only be installed by a competent person, in accordance with current regulations and the manufacturers instructions. If you require further advice concerning the installation of our products – especially where the installed dimensions may be critical to your choice and the location of the product – please contact our customer service department on 0870 727 0101 or consult your installer.

Please note that the dimensions contained within this brochure do not in all cases include clearances required around installed products for safe operation.

Useful Numbers

Tel: Customer Services: 0870 727 0101
Brochure line: 0870 727 0115

Fax: Customer Services: 0870 727 0102
Brochure line: 0870 727 0123

Email: customer.services@glendimplex.com

Website: www.dimplex.co.uk

Dimplex, Twin Sensor and Quartzray are all Registered Trade Marks in the United Kingdom.

Dimplex Optiflame fires are protected by patent Nos: GB2230335, AU621713, USA4965707, IE63651 and NZ232435.

All the Optiflame products shown in this brochure are protected by intellectual property rights owned by Glen Dimplex UK Limited or members of the Glen Dimplex Group on an international basis. The Glen Dimplex Group of Companies will actively protect these rights.

Dimplex®

Making life comfortable

Marketing Department, Millbrook House, Grange Drive, Hedge End, Southampton, SO30 2DF Telephone: 0870 077 7117 Fax: 0870 727 0109

Designed and produced by Carrington Caunter Associates Limited, Christchurch (Bournemouth), Telephone 01202 499612

Selected furniture supplied by BoConcept, Bournemouth / The Furnishing Place, Maidenhead.

Kitchens from Interfit Design Studio, New Milton, Hants. Locations courtesy of: Broomhill Conservatories, Christchurch, Dorset.
Coastal Bathrooms, New Milton, Hants. Everton Nurseries Ltd, Everton, Hants.