



**GOBLIN
TOOLS**

SKU: CLXPG21KT

Revision 2022.1.0



CLX-PG21

Green Beam

Crossline Laser Level Kit

INSTRUCTION MANUAL

CONTENTS

SAFETY	3
ITEM CHECKLIST	3
LASER OVERVIEW	4
USING THE LASER	4
MAGNETIC MOUNT	6
MOUNTING TO A TRIPOD (NOT INCLUDED)	7
USING A DETECTOR (NOT INCLUDED)	7
CARE AND MAINTENANCE	8
WARRANTY	8
TROUBLE SHOOTING	9
CUSTOMER SUPPORT	9
EU DIRECTIVES AND DISPOSAL	9
SPECIFICATIONS	9

SAFETY

Read the following safety instructions before attempting to operate this tool.

Keep these instructions in a safe place or store in the carry case for future reference.

SAVE ALL WARNINGS AND INSTRUCTIONS FOR FUTURE REFERENCE.



WARNING!
Read and understand all instructions.

- Use the tool only with the specifically designated batteries.
- Store the tool out of reach of children and other untrained persons. Laser tools are dangerous in the hands of untrained users.
- Use only accessories that are recommended for your model.
- Tool service must be performed only by qualified repair personnel. Repairs, service or maintenance performed by unqualified personnel will void the warranty. Only approved and authorised service technicians can carry out warranty repairs.
- Do not use optical tools such as a telescope or transit to view the laser beam. Serious eye injury could result.
- Do not place the tool in a position which may cause anyone to intentionally or unintentionally stare into the laser beam. Serious eye injury could result.
- Do not position the tool near a reflective surface which may reflect the laser beam toward anyone's eyes. Serious eye injury could result.
- Do not use optical tools to view the laser beam.

- Do not set up the tool at a position where the laser beam can cross any person at head height.
- Do not let children come in contact with the tool.
- Turn the tool off when it is not in use. Leaving the tool on increases the risk of staring into the laser beam.
- Do not operate the tool around children or allow children to operate the laser. Serious eye injury may result.
- Position the tool securely on a level surface. Damage to the tool or serious injury could result if the tool falls.
- Do not remove or deface warning labels.
- If the text on the warning label is not in your native language, cover it with the appropriate label supplied before commencing operation of the laser.



WARNING!
Do Not Disassemble The Laser.

There are no user serviceable parts inside. Disassembling the tool will void all warranties on the product. Do not modify the product in any way. Modifying the tool may result in hazardous laser radiation exposure.



CAUTION!
Class 2 Laser Product

- Never look into the laser beam directly and intentionally.
- Do not use optical tools to view the laser beam.
- Do not set up the tool at a position where the laser beam can cross any person at head height.
- Do not let children come in contact with the laser.



ITEM CHECKLIST

The following items are included with your laser level.

1. CLX-PG21 laser level
2. Magnetic mount
3. Laser target
4. USB-A to USB-C charging cable
5. USB-A charger
7. Hard carry case

LASER LEVEL OVERVIEW

- | | |
|--|---|
| <ul style="list-style-type: none"> 1 Laser port 2 Control panel 3 Power / locking switch 4 Charging port | <ul style="list-style-type: none"> 5 1/4"-20 thread 6 Manual mode / detector (pulse) mode 7 Detector (pulse) mode indicator 8 Power level indicator |
|--|---|

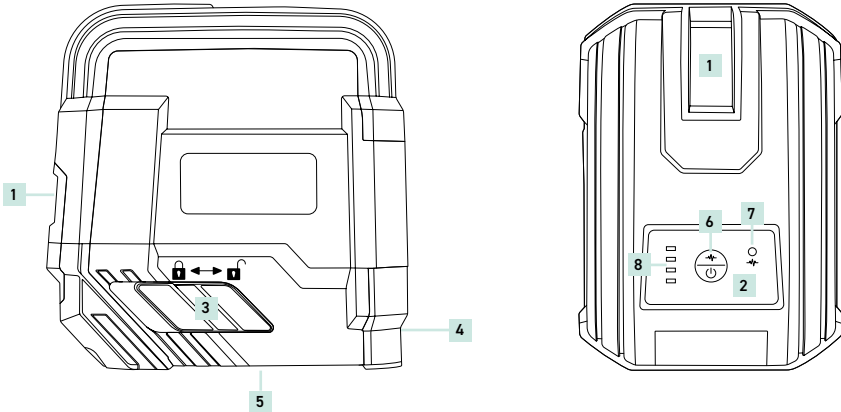

USING THE LASER LEVEL

POWER SUPPLY

- The laser level is supplied with a lithium-ion battery as its power source.

Charging the battery

- Insert the charging cable (USB-C) into the charging port on the laser (Fig.1).
- Insert the charging cable (USB-A) into the power adaptor. Insert the power adaptor into the power outlet.
- Progress will be shown by the power indicator display on the laser as below:

<ul style="list-style-type: none"> Green (flashing): Battery is charging 	<ul style="list-style-type: none"> Green (constant): Battery is charged
--	---

- Charging time is approximately 6 hours for a depleted battery.

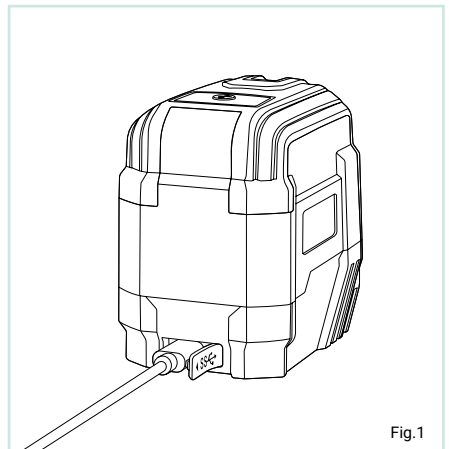

Fig.1

USING THE LASER LEVEL (continued)

SETUP

- Select a place as close as practical to the work site. Ensure the location is clear of traffic.
- Place the laser on a level surface such as a bench, floor or mount.

OPERATION

Powering on (self-levelling)

- To turn the laser level on, slide the **power / locking switch** to the “unlocked” position (Fig. 2). Self levelling will commence and the horizontal and vertical beams will activate (Fig.3).
- If the laser level is outside the self levelling range the laser level will not level. The laser beam/s will flash continuously to alert the user that it is outside of its levelling range. If this occurs, reposition the laser level onto a level surface until it can level off.
- The included laser target can be used to assist with visibility of the laser beam in non ideal light conditions.

i In bright outdoor conditions, visible distance will be significantly reduced. For outdoor use, it is recommended to purchase an optional detector.

Powering off (self-levelling)

- To turn the laser level off, slide the **power / locking switch** to the “locked” position.

Manual mode

- Ensure the **power / locking switch** is in the “locked” position.
- Press the **manual mode** button. The horizontal and vertical lines will activate.
- The laser level can now be tilted to the desired angle. The laser lines will flash every 5 seconds to alert the user that the laser level is in manual mode.
- To exit manual mode, press and hold the **manual mode button** for 2 seconds. The **self-levelling / manual mode indicator** LED will deactivate.

i When in manual mode the laser level will **not** self level and correct for vibrations and/or disturbances.

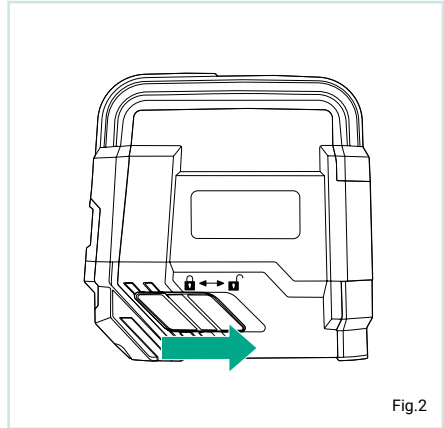

Fig.2

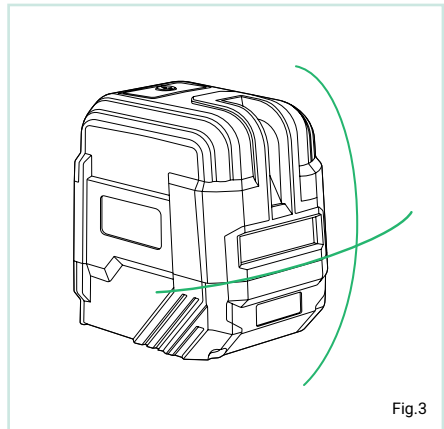
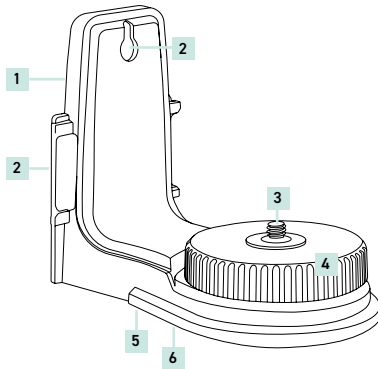

Fig.3

MAGNETIC MOUNT

MAGNETIC MOUNT OVERVIEW

- 1 Magnets
- 2 Screw fixing point
- 3 1/4"-20 thread (male)
- 4 1/4"-20 thread thumb screw
- 5 5/8"-11 tripod thread (female)
- 6 1/4"-20 thread (female)



USING THE MAGNETIC MOUNT

Mounting onto a magnetic surface

- Attach the laser level to the mount using the thumb screw (Fig. 4).
- Attach the mount to a metal surface, ensuring that the mount has a strong hold before releasing your hands.
- To rotate the laser level on the mount, loosen the thumb screw, position the laser level, and then re-tighten the thumb screw.

Mounting via screw fixing points

- Attach the laser level to the mount using the thumb screw (Fig. 6).
- Fix a screw into a secure surface and hook the mount over the screw, ensuring that the mount has a strong hold before releasing your hands.
- To rotate the laser level on the mount, loosen the thumb screw, position the laser level, and then re-tighten the thumb screw.

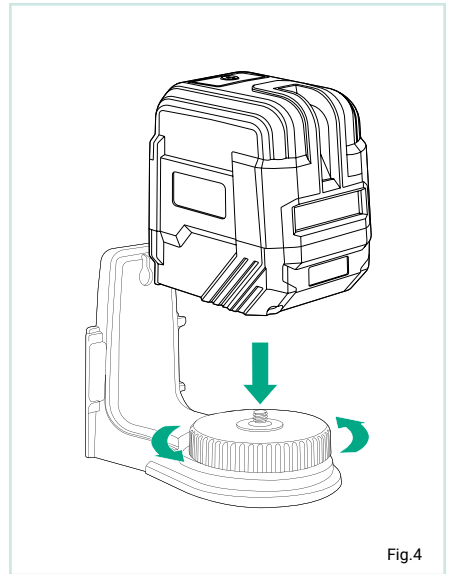

MOUNTING TO A TRIPOD

NOT INCLUDED

- i** A tripod can be purchased from your nearest measurement tool dealer. The below instructions are generic only and set-up methods may vary between models. Refer to the documentation from the tripod manufacturer for details.
- Extend the tripod legs to the required height and ensure the legs are spread wide enough so that the tripod platform is stable. Secure the legs in place (refer to the documentation from the tripod manufacturer for details).
 - Place the laser level onto the tripod and mount via the male thread (5/8" or 1/4") into the base until firm. Do not over tighten as this may cause damage to the laser level or tripod.

NOTE: adjustment methods will vary on tripod models. Always ensure that any locking levers are unlocked before making adjustments and returned to the locked position when the adjustment is complete.

- If using an elevating tripod with a measuring scale on the centre column, the height can be adjusted as required.



WARNING! Attaching the laser to a tripod without the correct thread size may cause damage.

USING A DETECTOR

NOT INCLUDED

i The detector and clamp is an optional accessory used to aid with locating the laser beam in bright conditions.

Please refer to the following information to determine compatibility when choosing a detector:

Detector type: Green and/or Hybrid.

Green beam lasers are only compatible with detectors designed to detect a green beam. Hybrid detectors are designed to detect green or red laser beams.

Frequency: 5000Hz.

The detector must be designed to detect a pulse frequency of 5000Hz.

Please check with the manufacturer's specifications to determine compatibility. For more information about choosing a detector, visit www.goblintradetools.com.

OPERATION WITH A DETECTOR

- Press the **manual mode / detector mode button** on the laser level to enter into pulse mode. The **detector mode indicator LED** will activate. The laser beams will appear to dim when detector mode is activated.
- Power on the detector (refer to the documentation provided by the manufacturer).
- Hold the detector upright for horizontal beams (Fig. 5). Rotate the detector 90° for vertical beams (Fig. 6).
- Move the detector until alignment with the laser beam is achieved. Detector functions vary between models. Please refer to the documentation provided by the manufacturer for details on the operation of the detector.

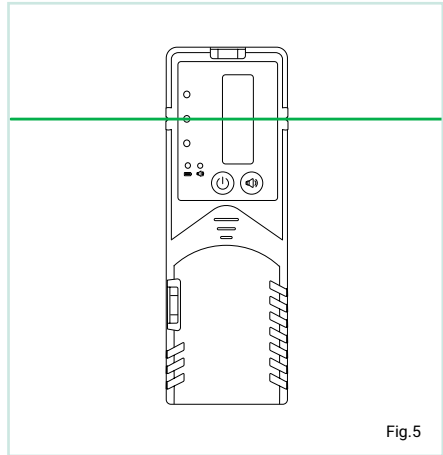

Fig.5

Image is for illustrative purposes only.

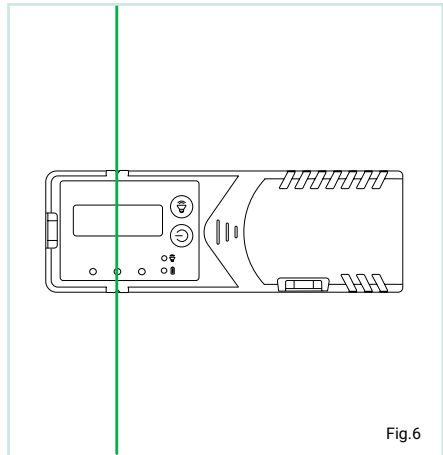

Fig.6

Image is for illustrative purposes only.

CARE & MAINTENANCE

1. This is a precision measuring tool and should always be handled with care and transported within the carry case provided.
2. Always turn the laser level off when transporting the laser level or moving around the job site.
3. Whenever possible, store the laser level in a dry, shady location.
4. Calibration of the laser level is recommended: every six months, if ongoing accurate levelling is required, or an impact has occurred.
5. The operator should check the accuracy of the tool before precision levelling is attempted. Failure to do so may result in inaccurate measurements.
6. Clean the laser level with a dry, soft cloth after use in dusty, damp or wet conditions before storing.
7. Smudges and fingerprints may be removed with a damp tissue or a soft, lint-free cloth.

WARRANTY

All Goblin Tools measurement tools are carefully checked and tested to our precise quality assurance standards.

We offer a warranty in accordance with the following conditions:

1. Our warranty provides the correction of deficiencies to the tool once verified by an authorised service centre that the deficiencies were caused by a manufacturing fault within the warranty period.
2. The standard warranty period is 4 years from the date of purchase. The warranty period can be extended to 8 years upon registration of the tool within 30 days of purchase.
3. The warranty does not cover:
 - a) Calibrations and components that are subject to wear and tear.
 - b) Defects in the tool caused by non-compliance with the operation instructions, improper use, abnormal environmental conditions, inappropriate operating conditions or insufficient maintenance.
 - c) Defects caused by using accessories or spare parts other than approved parts.
 - d) Services or repairs carried out by non-authorised persons.
4. Defects recognised by an authorised service centre as being covered by the warranty shall be corrected either by repair or replacement of the tool.
5. The warranty claim must be lodged within the warranty period. This requires the complete tool with the original sales receipt containing the purchase date and place of purchase. Partial or disassembled tools cannot be submitted for a warranty claim.
6. Services provided under warranty do not lengthen or renew the warranty of the tool.

The above guarantees apply to tools that are purchased in the countries and regions specified online at www.goblintradetools.com

4 YEAR STANDARD WARRANTY PERIOD

1. The warranty period for your tool is 4 years from the date of purchase.
2. The warranty period for batteries, battery packs and chargers is 1 year from the date of purchase.
3. Calibrations are not covered under warranty as they are deemed wear and tear.
4. All products have a standard warranty period, you do not have to register your products to obtain the standard warranty period.
5. To claim under this warranty, the date of purchase of the tool must be documented by an invoice/receipt.

8 YEAR EXTENDED WARRANTY PERIOD

1. The extended warranty is available on selected tools only.
2. You may extend the warranty period for your tool (laser level, optical level or laser distance measurer) to 8 years from the date of purchase. Accessories are excluded from the warranty extension and remain at the 4 year warranty period.
3. The warranty period for batteries, battery packs and chargers is 1 year from the date of purchase.
4. Calibrations are not covered under warranty as they are deemed wear and tear.
5. To obtain the extended warranty, the registration process must be completed within 30 days from the date of purchase.
6. Failure to register your product online and/or submission of a valid invoice/receipt will void the warranty extension.
7. Please ensure ALL information submitted/uploaded is correct.

Extended warranty is ONLY available via online registration, offline (mailing in of warranty registration) will not be accepted.

Visit www.goblintradetools.com to register.

TROUBLE SHOOTING

Error	Cause & Solution
Laser does not turn on	<ul style="list-style-type: none">The battery pack may require charging or need to be replaced due to age and / or a high number of charging cycles.
Laser does not remain on for long periods of use.	<ul style="list-style-type: none">The battery pack may require charging or need to be replaced due to age and / or a high number of charging cycles.
Laser does not level off	<ul style="list-style-type: none">The laser level may be outside its self levelling range and may require an adjustment before self-levelling can commence.The laser level may have impact damage.
Battery pack will not charge or is not lasting long in use	<ul style="list-style-type: none">The battery pack may require charging or need to be replaced due to age and / or a high number of charging cycles.

CUSTOMER SUPPORT

To assist you with any queries or technical questions please contact customer support.

United Kingdom: 0808 189 1152

All other countries / regions:

Visit www.goblintradetools.com for more information

Registered Business Address:

98 Middlewich Road, Northwich,
Cheshire, CW9 7DA United Kingdom

SPECIFICATIONS

Specifications	CLX-PG21
Product code	CLXPG21KT
Warranty	8 Years*
Accuracy	±2mm at 10m (±1/10in / 0.06in at 30ft)
Operating range (indoors)	30m (98ft) [^]
Levelling range	±3°
Laser class	2 Green
Battery life	12 hours
Battery type	12V 2000mAh Li-ion battery (internal)
Vertical lines	1
Horizontal lines	1
IP rating	54
Weight (g)	298
Dimensions (mm)	86 x 62 x 90

*With online registration (4 years without registration).
Please refer to page 8 for details.

[^] Maximum operating range can only be achieved indoors in ideal light conditions.

RESPONSIBLE DISPOSAL

Please do not throw any electrical equipment (including those marked with the crossed out wheeled bin symbol) in your bin.

This device complies with all necessary standards for the free movement of goods within the EU. This product is an electric device and must be collected separately for disposal according to the European Directive on waste electrical and electronic equipment.

Whilst every attempt is made to ensure the accuracy of all information within this instruction manual, Spot-on Laser & Tool Company UK Ltd reserves the right to correct errors or omissions at any time.



**GOBLIN
TOOLS**

© 2023 Spot-on Global Group Ltd. Goblin Tools is a trademark of Spot-on Global Group Ltd and is used under license by Spot-on Laser & Tool Company UK Ltd. All Rights Reserved.