

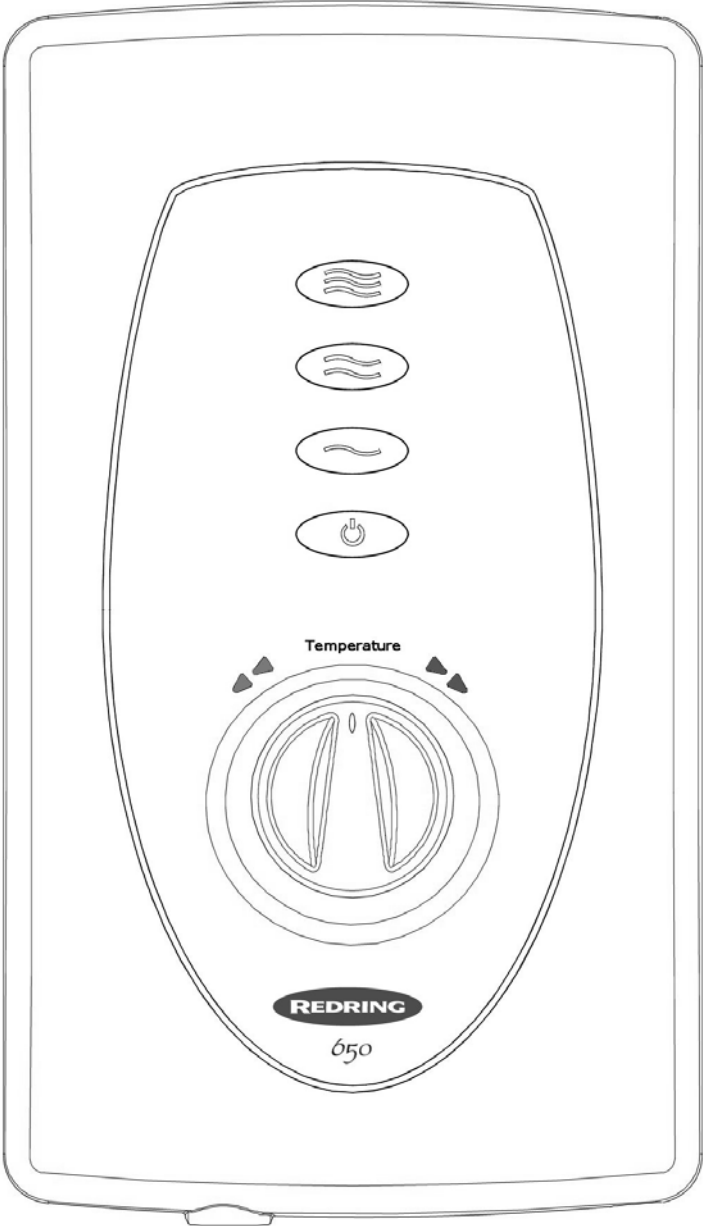

650

# Shower Handbook

(Also covers 650 chrome variant)



**IMPORTANT:**

**Please retain this booklet for future reference**

## CONTENTS

	Page
How to use your shower	2
How your shower works	3
What to do if things go wrong	5
Installation instructions	6
How to maintain your shower	10
Guarantee	12

### How to use your shower

1. Ensure the electricity and water are turned on to the unit
2. Functions of buttons: -  
**Button A** – Starts shower on ‘HIGH’ giving maximum power.  
**Button B** - Starts shower on ‘MEDIUM’ giving economy setting.  
**Button C** - Starts shower on ‘COLD’ giving water with no heating.  
**Button D** – ‘Shutdown’ switches the shower off and cools the water automatically.

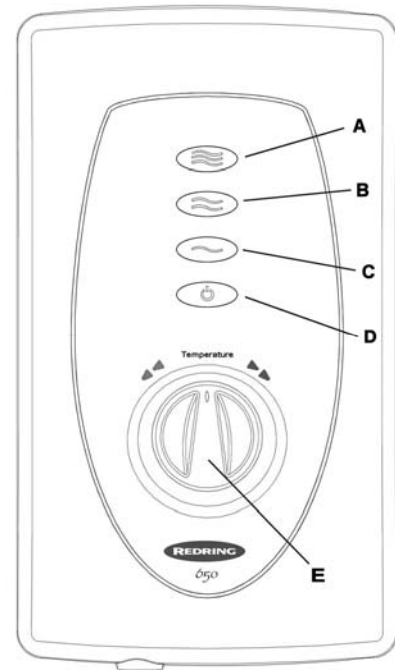

Diagram 1

Your shower has 3 power settings selected by pushing the corresponding button on the front cover. It can be started by pressing A, B or C buttons. Once pressed, a light will illuminate above the button confirming that power selection has been made.

3. Once either **A (HIGH)** or **B (MEDIUM)** have been pressed you will need to adjust the temperature of the water. This is done by rotating knob “E”. if this is too low then turn the knob anti clockwise and allow 20 seconds for the temperature to settle. Repeat **Diagram 1** procedure until the temperature is to your liking.
4. If the temperature is too high then turn knob “E” clockwise allowing 20 seconds between adjustments. The final adjustment can be anywhere on the scale. See diagram 3 for relationship of flow to temperature.
5. Once a temperature setting to your liking has been achieved knob “E” will rarely need adjusting, e.g. Adjust for variations of incoming mains water temperature between summer and winter.
6. When you have **finished** showering, **push button “D” only**. The electricity to the elements is then disconnected and the adjacent light will flash, water will continue to flow for approximately 5 seconds before switching off. This reduces the temperature of the water in the unit for the next user. Switch the electricity off at the ceiling switch or local isolator.
7. Your shower is designed to stabilise temperature changes caused by water pressure fluctuations. These can result from toilets being flushed or taps being turned on or off. When this happens your showering temperature will be held within a controlled band, providing that the minimum pressure required by the shower is maintained.
8. Your shower requires a minimum operating pressure of 100 kPa (1.0 bar, 14.5 p.s.i.). At pressures above 100 kPa (1.0 bar, 14.5 p.s.i.) it will minimise temperature fluctuations detailed in note 7. If the water pressure falls below 100 kPa (1.0 bar, 14.5 p.s.i.), it is likely that the pressure switch will turn off the power to the heating elements, resulting in a cold shower.

9. During normal operation if the shower senses an overheated water temperature then the thermal cutout will switch off the heating elements. Water will continue to flow and as the water temperature falls the heating elements will be turned back on. If the unit continues to cycle then increase the flow rate by turning knob “E” clockwise and check that the handset does not require de-scaling. If it still continues to cycle then press button B to the MEDIUM power setting. (Knob E will need adjusting).

10. Note that knob “E” **IS NOT A TAP** and does not turn the water off.

**WARNING! DO NOT SWITCH THE SHOWER ON IF YOU SUSPECT IT OF BEING FROZEN. WAIT UNTIL YOU ARE SURE IT HAS THAWED OUT.**

### Redring After Sales Service

We offer a technical advisory service on the telephone to contractors and other customers with problems in the field.

**RING 0870 9000 430**

Spare parts can be supplied against any debit or credit cards.

**RING 0870 0102 829**

Remember to quote the exact type of shower, as written on the front of the shower and on this leaflet. It may also be of use to have a note of the model and serial number as stated on the underside the shower.

### How your shower works

Your shower is designed for convenience, economy and safety of use

1. Water is heated instantaneously as it flows over the heating elements in the copper heating tube. (Diagram 2).
2. The required water temperature is achieved by adjusting the rate of water flow. Diagram 3 shows the principle involved in relating temperature rise to flow rate. The higher the water flow the lower the temperature rise, and vice versa. The temperature of the water supplied from the mains can vary considerably throughout the year from 5 to 20°C. This means that in Winter, the flow rate will be less than in the Summer to achieve the same outlet temperature. In summer the ‘MEDIUM’

Diagram 2

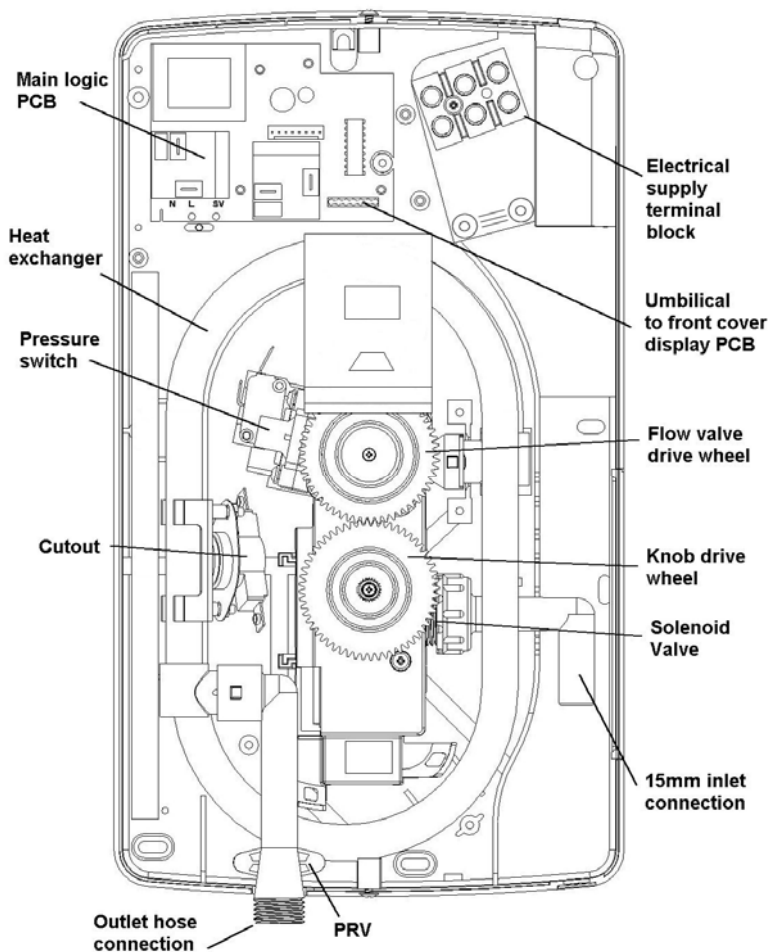

power setting may give adequate hot water.

3. The heaters are only switched on when sufficient water is flowing. This is done automatically with a switch, which works on water pressure.
4. The water is turned on and off by the solenoid valve built into the shower. This is switched on by button A, B or C. (diag. 2)
5. The flow of water is automatically held at the level set by the user even though the supply pressure may vary. (See 'How to use your shower' note 7).
6. If the water supply falls below a set limit, the pressure switch will operate and switch off the power to the elements.
7. As a further safeguard, a thermal cutout switches the power off if the water temperature climbs above a set limit. The cutout gives an audible click when it switches off, but will reset itself if cold water is run through the shower for 10 to 20 seconds.
8. The pressure relief device is to safeguard against extreme abuse conditions.
9. There are 3 defined spray plate settings adjustable by rotating the spray plate, (see diagram 4). The modes have a positive "click" to identify them. If desired many combinations between the 3 can be achieved.

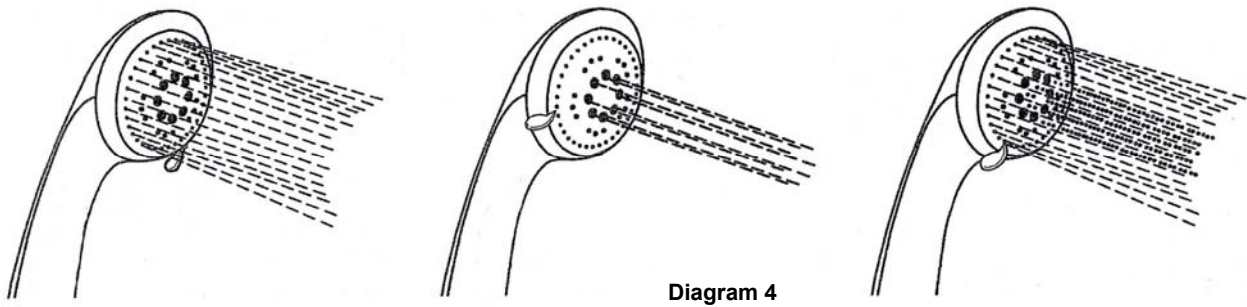
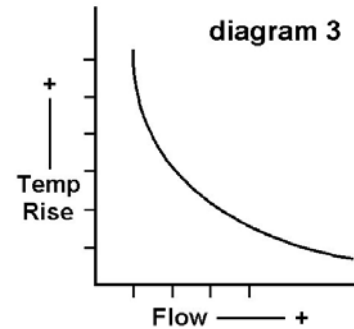

**IN ORDER TO MAINTAIN THE PERFORMANCE OF YOUR SHOWER YOU MUST CLEAN THE SHOWERHEAD.**

**All water contains particles of lime, which build up in the showerhead and unit reducing the performance. It is therefore important to clean the showerhead regularly. This is simply done by rubbing the rubber nozzles. In severe cases you may need to dip the spray plate into a suitable de-scaling solution.**

The frequency of this will vary from weekly to quarterly depending on the water hardness and experience.

Check the spray plate is then free to rotate to give the three settings.

In some winter conditions, when the incoming mains water is particularly cold it may be necessary to select the inner or outer spray pattern only. This will ensure correct operation of the shower with a slightly lower water flow rate

Note: After use it is normal for some water to drip from the showerhead for a few moments, this inhibits scale build up over prolonged use.

## What to do if things go wrong

### SELF HELP

If the shower is unsatisfactory, make the following checks before calling out the contractor. Any of these adjustments could restore the performance

<b>a) Water too HOT</b>	Increase water flow by adjusting the temperature control clockwise. Clean spray plate holes. (Select outer or combination spray patterns). Switch power to MEDIUM setting. Increase pressure of water supply e.g. fully open service valve or stop cock. Check hose is not kinked restricting the water flow.
<b>b) Water too COLD</b>	Decrease water flow by adjusting the temperature control anti-clockwise. Select inner or outer spray patterns only. Switch power to HIGH setting.
<b>c) Spray pattern poor</b>	Clean spray plate and flush heater with handset removed. Select inner / outer spray pattern.
<b>d) Water goes cold while using shower</b>	Check power setting lights are on Check water pressure has not fallen so far as to let pressure switch cut out, e.g. another tap drawing water off. Raise position of handset.
<b>e) Broken parts</b>	Please contact our spares department on 0870 0102 829. Fitting instructions are provided with spares.

### PROFESSIONAL SERVICE

If the previous checks fail to restore the performance, you should either contact the Redring Technical Advisory Service or seek the assistance of a qualified plumber and / or electrician.

**The person who installed the shower is probably the best one to repair it and is certainly the person to contact if you have a problem in the guarantee period.**

The following additional checklist is provided for the benefit of the qualified serviceman.

**WARNING – SWITCH OFF THE ELECTRICITY AT THE ISOLATING SWITCH BEFORE REMOVING THE COVER TO MAKE CHECKS.**

<b>a) Water too HOT</b>	Water flow restricted by blockage in filter of solenoid valve. Switch off water and undo plastic nut on elbow, loosen brass nut to swing elbow away from solenoid. Remove filter in solenoid with long nosed pliers and flush clean.
<b>b) Water too COLD</b>	Check circuit through thermal cut-out Check circuit through microswitch on the pressure switch Check each element circuit. Check tightness of electrical connections.
<b>c) Water leaks from burst pressure relief valve</b>	Check for cause of high pressure and remove it. Blockage on outlet i.e. blocked spray plate. Replace the pressure relief disc.
<b>d) Water does not flow when button “A” “B” or “C is pressed</b>	Check the circuit through the solenoid coil. Check circuit through microswitch Possible PCB fault, if defective, then replace. Power supply not reaching shower.

## Installation instructions

Check that the electrical rating shown on the showers matches the mains supply. A competent installer must undertake all installations. If in any doubt, advice and assistance should be sought from a qualified plumber and/or electrician. Installations and wiring must conform to current BS7671 IEE regulations (UK)

### WARNING! DO NOT INSTALL THIS SHOWER IN A ROOM WHERE IT MAY BE SUBJECT TO FREEZING

We recommend that the installation be done in the following sequence.

- a) Fixing the shower to the wall
- b) Plumbing
- c) Electrical connections

#### a) Fixing the shower to the wall

1. Position the riser rail at the height recommended in diagram 5 and mark its position.
2. Position the heater so the sides of the unit are vertical and the top is level with, or up to 0.6 metres (2ft) maximum below the top of the riser rail. Choose a flat piece of wall to avoid the possibility of distorting the back plate thus making the front cover a poor fit.
3. Adjust the positions to get the most convenient arrangement taking the following into account.
  - a) The possible need to use the handset over the sink for hair washing etc.
  - b) The heater must not be mounted in the direct spray from the showerhead.
  - c) The handset must not be able to come into contact with any used water in the bath or basin. If it can, even after the hose has been retained by the hose retainer (see diagram 13), then a vacuum breaker must be fitted. It should be noted that these devices are liable to minor leakage so they must be positioned so that any drips are not detrimental.
4. Fix the riser rail with screws provided. The fixing holes at the base of the brackets will be disclosed by removing the plastic fronts. Assemble as shown in diagram 13.

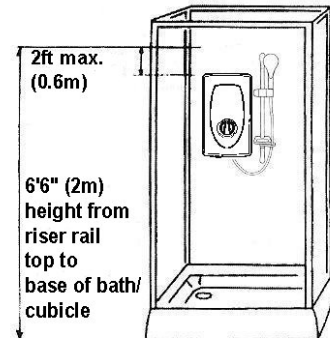

Diagram 5

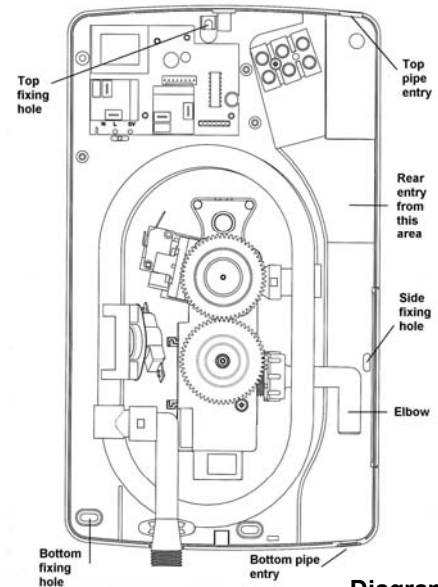
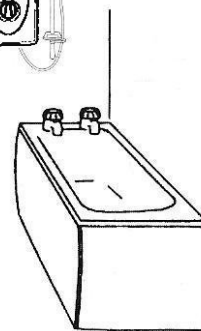

Diagram 6

5. Decide the position of the electrical cable inside the unit. If top or bottom entry is chosen (according to diagram 6), cut away the walls of the back-plate as shown in diagram 8. There is also the option to fit the cable from the rear in the channel provided.
6. Decide the cut away position of entry of the cold water pipe into the unit. Cut away the back-plate and front cover as shown in diagram 7 or 8. There is also the option to have rear entry (see later section on plumbing).

- If you have not yet done so, remove the front cover (complete with control knob) of the unit by undoing the retaining screws at the top and bottom of the unit and lifting the cover off. The top-fixing hole is a keyhole slot, and should be marked and drilled first. Tighten top screw with head protruding about 10mm from wall and hook the back-plate over the screw head. This allows for correct and accurate alignment of your shower before marking and fixing the bottom/side position. You may not wish to tighten up all 3 screws at this stage as the holes are elongated to allow for adjustment after other connections have taken place.

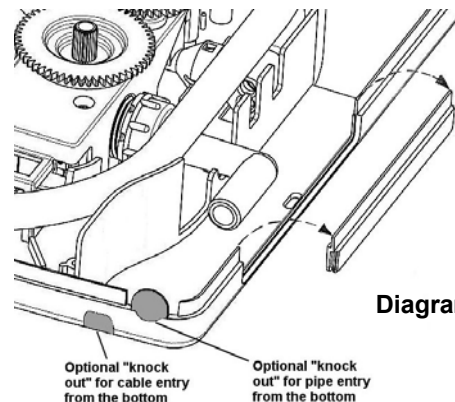

Diagram 7

**WARNING! TAKE CARE NOT TO DAMAGE THE PRINTED CIRCUIT BOARD IN ANY WAY. DURING INSTALLATION AVOID DUST AND DEBRIS GETTING ON IT.**

- Do not obstruct the pressure relief device found in the back-plate slot underneath the outlet connection (see diagram 2). Especially if silicone sealant or similar materials are used around the edges of the back-plate.

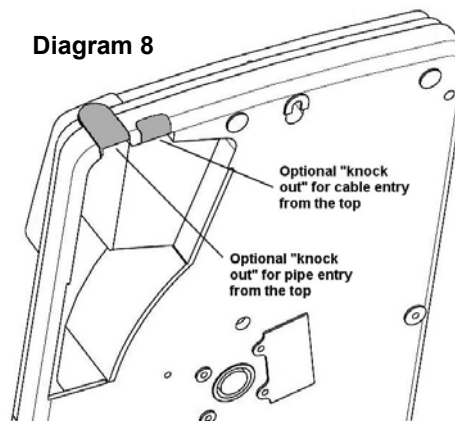

Diagram 8

- There are a number of clearly marked shields in the shower unit. These are important for the correct operation of this shower and **MUST NOT** be removed under any circumstances.

#### **b) Plumbing (see diagram 9)**

The heater should be connected to the mains cold water supply. This must have a minimum running pressure of 100kPa, 1.0 bar (14.5 p.s.i) and a maximum pressure of 1000kPa, 10 bar (145 p.s.i).

Before connecting the pipe-work to the shower ensure that pipe-work is flushed out.

- It is recommended that a WRAS (Water Regulations Advisory Scheme) listed isolating valve is fitted between the rising main and the unit. This will allow the unit to be serviced without turning off the cold water or exchanged without having to turn off the water at the water mains stop valve.
- The heater can be fed from a header tank provided this has a minimum head height of 10.5 metres (35ft).
- 15mm copper or stainless steel pipe should be used alongside with a standard compression fitting. In multiple shower installations correct pipe-work sizes should be calculated to maintain adequate flow to each shower.
- If top entry is chosen, turn the elbow 180° into the required position and fit a standard 15mm in line compression fitting. There is a removable side section, which will aid you with this (diag.7).
  - If rear entry is chosen, turn the elbow 180° and treat it as top entry except for the fitting of a 'Yorkshire' elbow in the rear channel. The removable side section will again be an aid.
- It is in order to use a WRAS (Water Regulations Advisory Scheme) approved sealant sparingly whilst avoiding excess finding its way into shower operating parts.

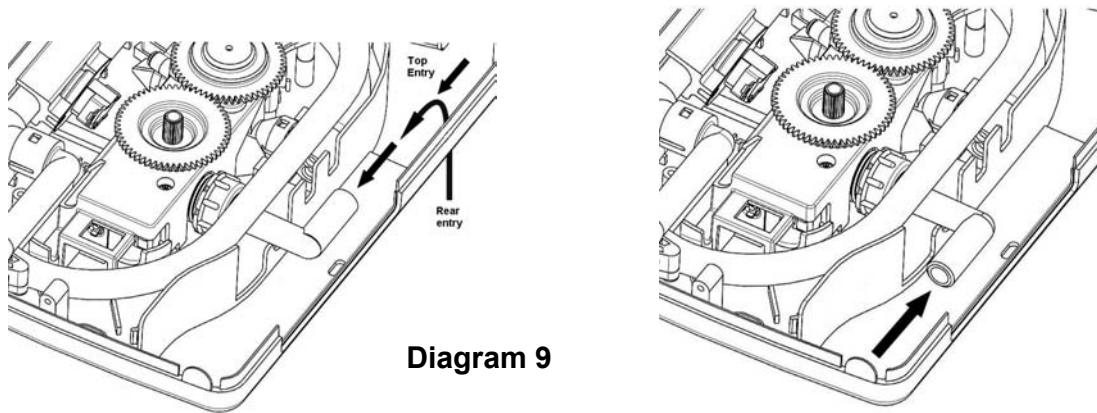

Diagram 9

6. With the stop valve connected, **flush the pipe-work through to remove any particles etc.**, before making the final connection to the shower. Blockage in the waterways (particularly the handset and solenoid valve) will prevent the heater working properly.
7. The shower is designed to have an open outlet and should only be used with 'Redring' recommended fittings. Do not connect the showerhead until after the shower front cover and removable side section are fitted.

**WARNING - DO NOT FIT A TAP ON THE SHOWER OUTLET. TAKE CARE TO AVOID RESTRICTING THE OUTLET AND FLOW FROM THE SHOWERHEAD OR THE PRESSURE RELIEF DEVICE.**

**d) Electrical Connections**

The electrical installation must be in accordance with the current BS. 7671 (I.E.E. regulations). If in doubt consult a qualified electrician.

1. The shower is designed for a single-phase A.C. electrical supply. Please check the rating plate on the unit to see what details apply.
- 2.

Cable Sizes	Fuse/ MCB
9.5 / 8.7kW 240 / 230V 10mm <sup>2</sup>	40 or 45A Cartridge fuse
10.5 / 9.6kW 240 / 230V 10mm <sup>2</sup>	45A Cartridge fuse / MCB

For the 9.5kW you may be able to use 6mm<sup>2</sup> cable if Method 1 (clipped direct) is used.

Remember to up rate the cable if it runs in thermal insulation in a loft, or for longer distance

3. A means for disconnection in all poles must be incorporated in the fixed wiring in accordance with the wiring rules. We recommend a ceiling switch mounted in a convenient position.
4. Cut back cable as in diagram 10. Connect cable to terminal block making sure that ALL the retaining screws are VERY tight and that no cable insulation is trapped in the block.

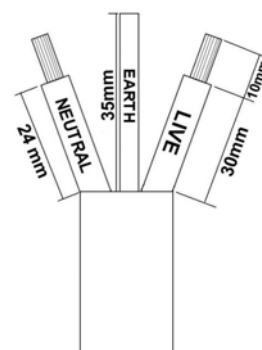
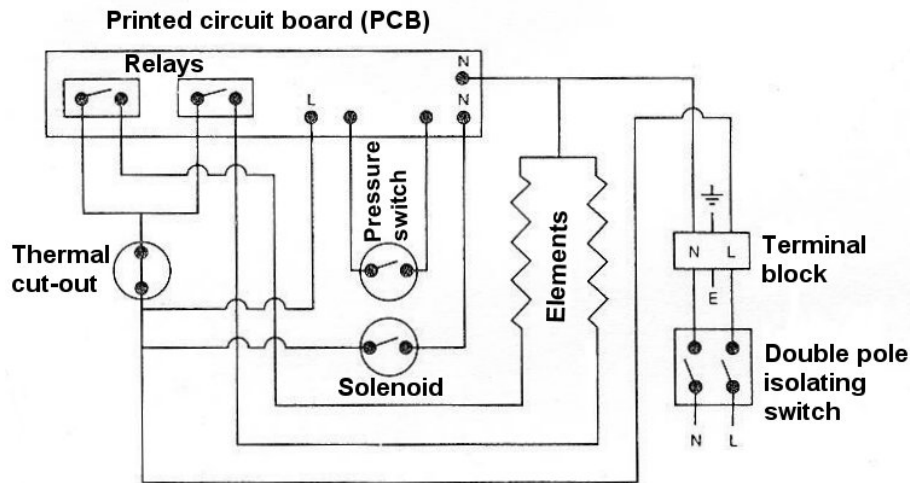

Diagram 10



Schematic Wiring Diagram

**WARNING - FAILURE TO COMPLY WITH THESE INSTRUCTIONS COULD RESULT IN A FAILURE OF THE TERMINAL BLOCK AND CABLING.**

5. **WARNING - THIS APPLIANCE MUST BE EARTHED.**

6. Ensure that the removable side section is fitted securely into the back-plate.

7. Re- connect cable to front cover PCB (one way fit) see diagram 11.

8. Fit the front cover back into position making sure the knob is aligned correctly with the flow valve (see diagram 12).

**WARNING - TAKE CARE WHEN REPLACING THE FRONT COVER TO AVOID DAMAGING ANY COMPONENTS.**

9. Operate the shower first without the handset to flush out particles, fit handset and then operate the shower as explained previously and check:

- That the water gets to a satisfactory temperature.
- Power selection does give a change in water temperature.
- Check again for leaks.
- That the holes in the spray plate are not blocked.
- Water flow can be adjusted by knob E

10. DEMONSTRATE OPERATION TO USER

11. LEAVE THESE INSTRUCTIONS WITH THE USER FOR FUTURE REFERENCE.

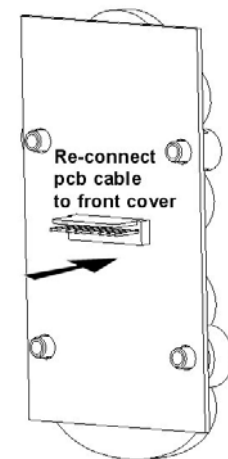

Diagram 11

## How to maintain your shower

It is recommended that the shower unit, riser rail, hose etc. can be cleaned using a soft cloth and that the use of an abrasive or solvent cleaning fluid be avoided, especially on any plated finishes (650 chrome only). Micro fibre clothes are recommended for cleaning the chrome (650 chrome only).

We recommend that before cleaning, the isolating switch be turned off, thus avoiding accidentally switching on the shower.

The showerhead should be periodically cleaned as previously detailed.

Diagram 12

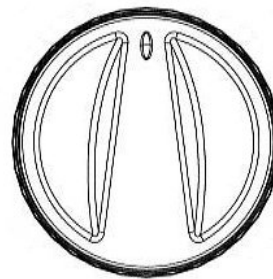

Rotate knob  
so pointer is  
as shown

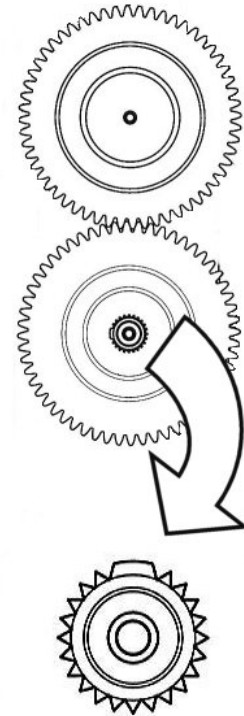

Rotate lower gear  
so drive is as  
shown

### Additional Accessories

White 2 metre Shower hose  
Water control tap  
Shower de-scaling powder  
Curtain and rail pack  
Curtain and rail pack with non-slip Bath mat

### Catalogue Number

83-593529  
93-792452  
95-711015  
83-792802  
83-792801

### Spares

White 650 cover complete  
Plated front cover complete (plated version)  
Plated control knob (plated version)  
Gear drive  
Outlet elbow assembly complete.  
Removable side section (grey)  
Removable side section (white)

93-597808  
93-597814  
93-593590  
93-593591  
93-593592  
93-593593  
93-591819

**Spares / accessories can be supplied against any Visa or Access cards from Redring Sales Hotline 0870 0102 829.**

Diagram 13

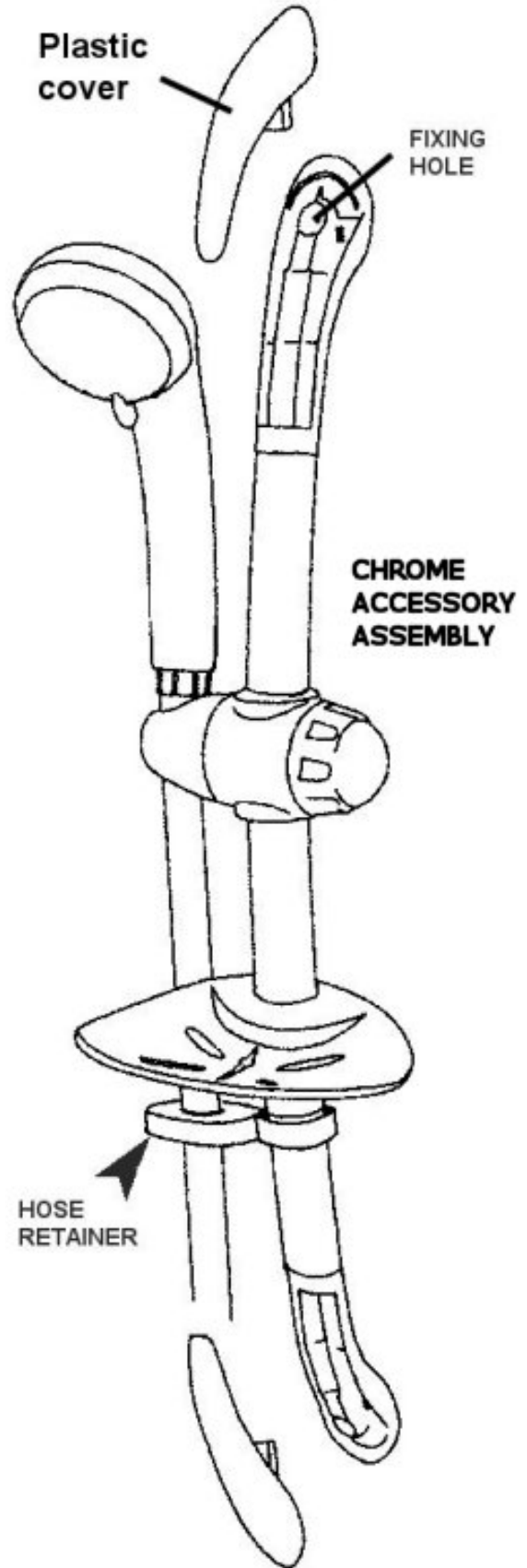
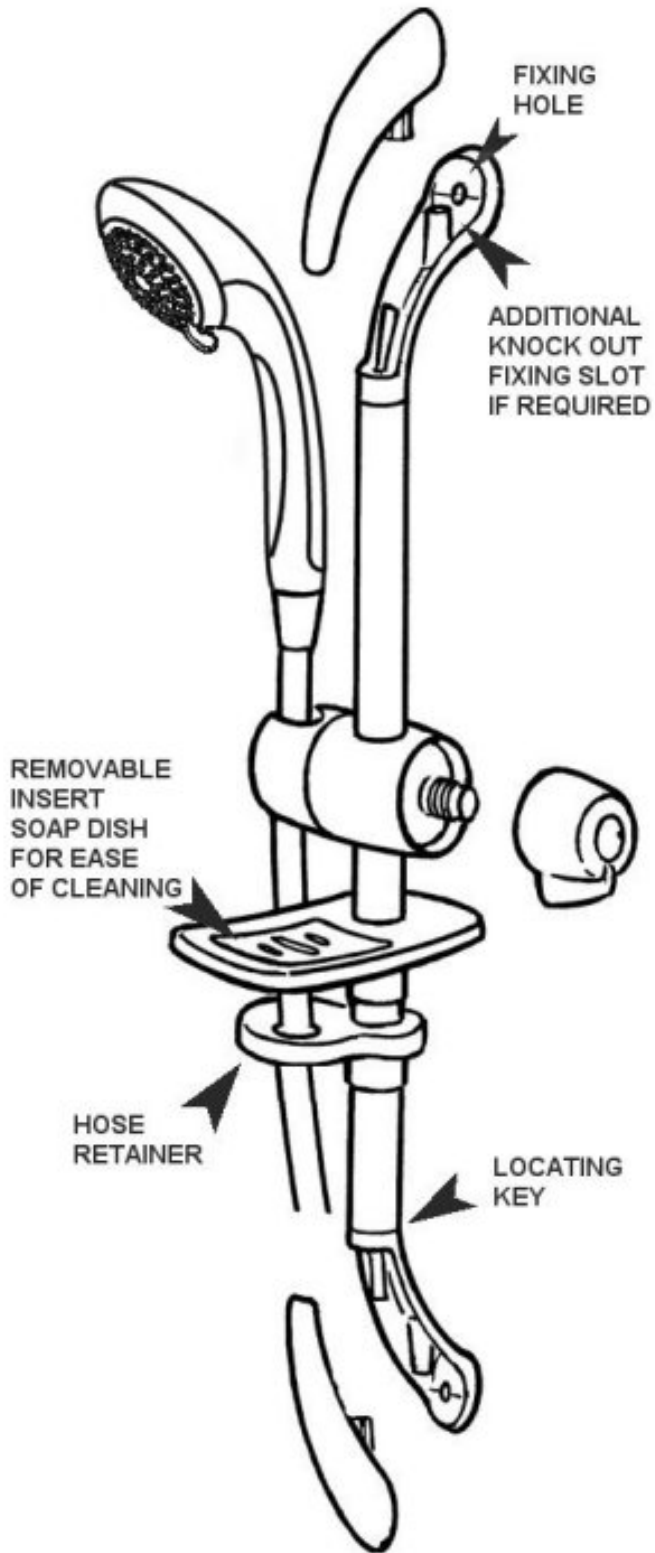

650 CHROME MODEL ACCESSORIES

# *Guarantee*

We, Applied Energy Products Limited, guarantee that should this instant water heater prove to be defective by reason of faulty workmanship or material within 36 months\* of the date of purchase or commencement of hire we will replace the defective parts FREE OF CHARGE on the condition that:-

- a) The appliance has been correctly installed and used only on the supply circuit or voltage stamped on the rating plate.
- b) The appliance has been used in accordance with these instructions and has not been tampered with or otherwise subject to misuse, neglect or accident.
- c) The appliance has not been taken apart, modified or repaired except by a person authorised by us.
- d) EVIDENCE of the date of purchase in the form of an invoice, receipt (hire purchase documents) is included with the appliance if returned under guarantee.
- e) The appliance has been used for domestic purposes only.

'This Guarantee does not affect your statutory rights'

\*Accessories covered for 12 months.



**REDRING**

**Full details of terms and conditions are available on request from: -  
APPLIED ENERGY PRODUCTS LTD.  
MORLEY WAY, PETERBOROUGH PE2 9JJ.  
Tel +44 (0)1733 456789 Fax: +44 (0)1733 310606 Website: [www.redring.co.uk](http://www.redring.co.uk)**