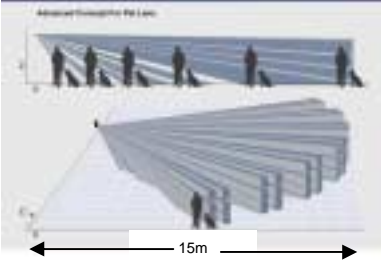
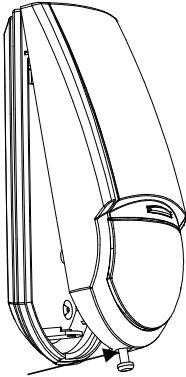
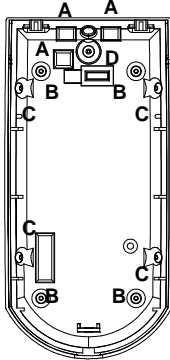
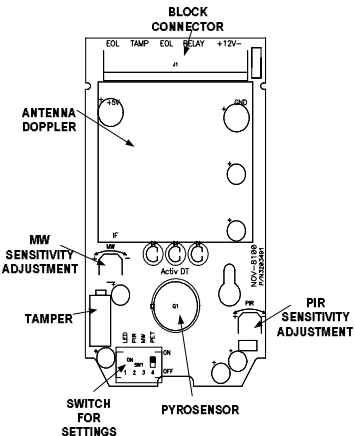

<h1 style="text-align: center;">Activ8 DT</h1> <h2 style="text-align: center;">PASSIVE INFRARED & MICROWAVE MOTION DETECTOR</h2> <h3 style="text-align: center;">With PET IMMUNITY</h3> <p style="text-align: center;">INSTALLATION INSTRUCTIONS</p> <p style="text-align: center;">P/N 7101491 REV. A A.Y.</p>	<p style="text-align: center;">PRODUCT DESCRIPTION</p> <p>A new generation of professional movement spread spectrum analyzing PIR & MW detectors.</p> <p>The Activ8 DT is a combination of PIR & MW detectors, providing protection from intruders by PYRO sensor element and MW (based on Doppler concept). Using micro controller for PIR & MW signal analyzing, with special ASIC technology for PIR pulse processing, assures "false alarm free" operation.</p>	 <p>The Activ8 DT provides immunity up to 25Kg. For better immunity avoid installation in areas where pets can reach upwards.</p>
---	--	--

<p style="text-align: center;">Activ8 DT FEATURES</p> <p>FEATURES</p> <ul style="list-style-type: none"> • Quad (Four element) PYRO sensor and hard lens for outstanding detection performance and elimination of false alarms. • Microwave detection based on Doppler concept. • Unique Microwave Motion Sensor Module with microstrip patch antenna. • VLSI based electronics with movement speed spectrum analysis. • Height installation calibrations free. • User-friendly installation with or w/o swivel bracket. • 2-way Microwave sensitivity adjustment. • 2-way PIR sensitivity adjustment. • BI directional temperature compensation. • Environmental immunity. • The Activ8 DT provides <i>pet immunity</i> up to 25Kg. Pet active below 1m. 	<p style="text-align: center;">DETECTION PATTERN</p> 	<p style="text-align: center;">TYPICAL INSTALLATION</p> <p>SELECT MOUNTING LOCATION</p> <p>Choose a location most likely to intercept an intruder. (Our recommendation is a corner installation). See detection pattern. The quad-element high quality sensor detects motion crossing the beam; it is slightly less sensitive detecting motion toward the detector. The Activ8 DT performs best when provided with a constant and stable environment.</p> <p>AVOID THE FOLLOWING LOCATIONS</p> <ul style="list-style-type: none"> • Facing direct sunlight. • Facing areas that may change temperature rapidly. • Areas where there are air ducts or substantial airflows. <p>The Activ8 DT performs better when provided with a constant and stable environment.</p>
--	--	---

<p style="text-align: center;">REMOVAL OF FRONT COVER</p>  <p>Unscrew the holding screw and open base</p>	<p style="text-align: center;">MOUNTING DETECTOR BASE</p> <ol style="list-style-type: none"> 1. To remove the front cover, unscrew the holding screw and gently raise the front cover. 2. To remove the PC board, carefully unscrew the holding screw located on the PC board. 3. Break out the desired holes for proper installing. 4. The circular and rectangular indentations at the bottom base are the knockout holes for wire entry. You may also use mounting holes that are not in use for running the wiring into the detector. (For option with bracket - lead wire through the bracket) 5. Mount the detector base to the wall, corner or ceiling. (For option with bracket install bracket). 6. Reinstall the PC board by fully tightening the holding screw. Connect wire to terminal block. 7. Replace the cover by inserting it back in the appropriate closing pins and screw in the holding screw. 	<p style="text-align: center;">KNOCKOUT HOLES</p>  <ol style="list-style-type: none"> A. Wire access holes B. Use for flat wall mounting C. Corner mounting - use all 4 holes. Sharp left or right angle mounting - use 2 holes (top and bottom) D. For bracket mounting
---	--	--

<p style="text-align: center;">DETECTOR INSTALLATION</p> <p>TERMINAL BLOCK CONNECTIONS</p> <p>EDL TAMPER EDL RELAY +12V-</p> <table border="1" style="width: 100%; text-align: center;"> <tr> <td>1</td><td>2</td><td>3</td><td>4</td><td>5</td><td>6</td><td>7</td><td>8</td> </tr> </table> <p>Terminals 1 & 4 - Marked " EOL " - End of line option.</p> <p>Terminals 2 & 3 - Marked " TAMPER " If a Tamper function is required connect these terminals to a 24-hour normally closed protective zone in the control unit. If the front cover of the detector is opened, an immediate alarm signal will be sent to the control unit.</p>	1	2	3	4	5	6	7	8	<p>Terminals 5 & 6 - Marked " RELAY " These are the output relay contacts of the detector. Connect to a normally closed zone in the control panel.</p> <p>Terminal 7 - Marked " + " (+12V) Connect to a positive Voltage output of 8.2 -16Vdc source (usually from the alarm control unit)</p> <p>Terminal 8 - Marked " - " (gnd) Connect to the negative Voltage output or ground of the control panel.</p>	<p style="text-align: center;">CIRCUIT LAYOUT</p> 
1	2	3	4	5	6	7	8			

SETTING UP THE DETECTOR

MW SENSITIVITY ADJUSTMENT

SWITCH 3 OF DIP-4 SWITCH FOR SETTINGS "MW SENSE" - provides sensitivity control of MW (DOPPLER) according to the environment.
Position Down – "OFF" – **High sensitivity**
 For normal operation – immediate detection.
Position Up – "ON" – **Low sensitivity**
 For harsh environments.

POTENTIOMETER "RV2" – adjustment according to protected area range.
 The potentiometer at mid-scale is equivalent to a distance of 15m, at min-scale – 7m.
 Rotate the potentiometer counter-clockwise to increase range, clockwise to decrease range.

Dimension change according to installation location and room size.

PIR SENSITIVITY ADJUSTMENT

SWITCH 2 OF DIP-4 SWITCH FOR SETTINGS "PIR SENSE" - provides sensitivity control of PIR according to the environment.
Position Down – "OFF" – **High sensitivity**
 For stable environments.
Position Up – "ON" – **Low sensitivity**
 For harsh environments.

POTENTIOMETER "RV1" – adjustment according to protected area range.
 Use RV1 to adjust the detection range between 68% and 100% (factory set to 84%). Rotate the potentiometer counter-clockwise to increase range, clockwise to decrease range.

After adjusting the sensitivity perform a walk test to verify optimum correct sensitivity in the protected area.

PET IMMUNITY SETTING

SWITCH 4 OF DIP-4 SWITCH FOR SETTINGS "PET" 15kg – 25kg
Position Up "ON"
 Immunity to an animal up to 15 kg
Position Down "OFF"
 Immunity to an animal up to 25 kg

You must reset the detector from Control Panel before the new settings will take effect.

SETTING UP THE DETECTOR

SWITCH 1 OF DIP-4 SWITCH FOR SETTINGS "LED" - LED Enable / Disable
Position On - LED ENABLE
 The RED LED will activate when the detector is in alarm condition.
Position Off - LED DISABLE
 The LEDS are disabled.

Note: the state of the switch "LED" does not affect the operation of the relay.
 When an intrusion is detected, the LED will activate and the alarm relay will switch into alarm condition for 2 sec.

LED INDICATORS (Fig.4)
 YELLOW LED - MW detection's
 GREEN LED - PIR detection's
 RED LED - Alarm

TEST PROCEDURE

Wait for one minute warm up time after applying 12 Vdc power. Conduct testing with the protected area cleared of all people.

Walk test

1. Remove front cover. Set LED to ON position.
2. Reassemble the front cover.
3. Start walking slowly across the detection zone.
4. Observe that the red LED lights whenever motion is detected.
5. Allow 5 sec. between each test for the detector to stabilize.
6. After the walk test is completed, you can set the LED to OFF position.

NOTE:

Walk tests should be conducted, at least once a year, to confirm proper operation and coverage of the detector.

MW PATTERN

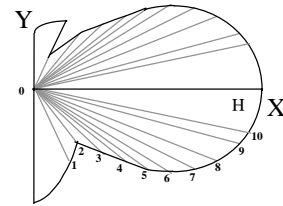
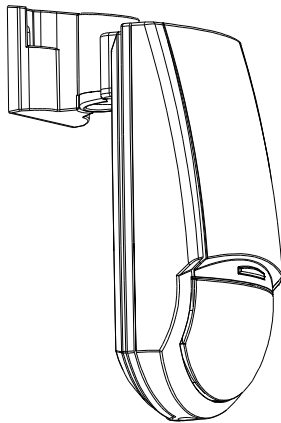

Table 1:

##	0	1	2	3	4	5	6	7	8	9	10
a	180	130	100	84	79	70	60	52	40	30	20
X	0	3	6	9	12	15	18	21	24	27	285
Y	105	6,09	7,15	8,98	8,01	105	1039	1024	873	723	503

X,Y are corresponds (m) of pattern points when H=30m

WALL INSTALLATION OPTION



CEILING INSTALLATION OPTION

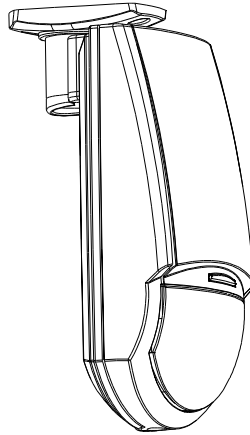

BRACKET INSTALLATION

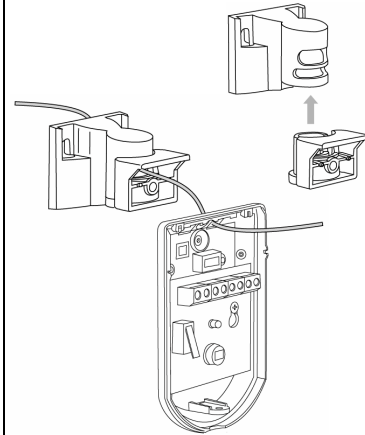

TECHNICAL SPECIFICATION

Detection Method	Quad element PIR & microwave pulse Doppler
Power Input	7.8 to 16 Vdc
Current Draw	Active : 25.5 mA Standby: 16.5 mA
Temperature Compensation	YES
Alarm Period	2 +/- 1 sec
Alarm Output	N.C 28Vdc 0.1 A with 10 Ohm series protection resistors
Tamper Switch	N.C 28Vdc 0.1A with 10 Ohm series protection resistor - open when cover is removed
Warm Up Period	1 min
LED Indicator	Yellow LED is blinking during warm up period and self testing, Red LED is ON during alarm Red LED: UNIT ALARM Green LED: PIR CHANNEL Yellow LED: MW CHANNEL
Dimensions	121mm x 60mm x 37mm
Weight (inc. battery)	120 gr.

For Technical Support, please call 01268 563 247.