

**B272M**  
**60cm Multifunction**  
**built in oven.**

Instruction manual



# User Manual for your Baumatic

## B272M

**60 cm Multifunction built in oven in mirror glass with aluminium frame**



  
**Baumatic®**  

---

*You will be mine ...*

***NOTE: This User Instruction Manual contains important information, including safety & installation points, which will enable you to get the most out of your appliance. Please keep it in a safe place so that it is easily available for future reference; for you or any person not familiar with the operation of the appliance.***

DD 18/03/08

## Contents

<b>Environmental note</b>	4
<b>Important safety information</b>	5 – 7
<b>Specifications</b>	8
Product and aperture dimensions	8
Product specifications	8
Standard accessories	8
Optional extras	9
Electrical details	9
Control panel	10
Oven programmer/timer display	10
<b>Setting and using the oven programmer/timer</b>	11-15
Selecting manual operation mode	11
Setting the time of day	11
Before first use	11
Setting the minute minder function	12
Setting the duration function	13
Setting the end cook function	14
Setting the start and end time function	15
<b>Selecting a cooking function and temperature</b>	16-19
Selecting manual operation mode	16
Selecting an oven function	16-17
Thermostat control knob	17
Oven operating light	17
Cooking guidelines	18
Warnings	18-19
Accessories	19
<b>Cleaning and maintenance</b>	20-22
Removable oven roof liner	21
Replacing the oven bulb	21
Removing the oven door for cleaning	22
<b>Installation</b>	23-25
Electrical connection	23
Installing the oven into the kitchen cabinet	24-25
<b>My appliance isn't working correctly</b>	25-27
<b>Contact details</b>	28

## Environmental note

**This appliance is marked according to the European directive 2002/96/EC on Waste electrical and Electronic Equipment (WEEE). By ensuring this product is disposed of correctly, you will help prevent potential negative consequences for the environment and human health, which could otherwise be caused by inappropriate waste handling of this product.**

The symbol  on the product, or on the documents accompanying the product, indicates that this appliance may not be treated as household waste. Instead it shall be handed over to the applicable collection point for the recycling of electrical and electronic equipment.

**Disposal must be carried out in accordance with local environmental regulations for waste disposal.**

**For more detailed information about treatment, recovery and recycling of this product, please contact your local city office, your household waste disposal service or the shop where you purchased the product.**



- The packaging materials that Baumatic uses are environmentally friendly and can be recycled.
- Please discard all packaging material with due regard for the environment.

## IMPORTANT SAFETY INFORMATION



Your safety is of the utmost importance to Baumatic. Please make sure that you read this instruction booklet **before** attempting to install or use the appliance. If you are unsure of any of the information contained in this booklet, please contact the Baumatic Technical Department.

### General Information

- This appliance is designed for domestic household use and can be built into a standard kitchen cabinet or housing unit.
- **IMPORTANT:** The adjacent furniture or housing and all materials used in the installation **must** be able to withstand a minimum temperature of 85°C above the ambient temperature of the room it is located in, whilst in use.
- Certain types of vinyl or laminate kitchen furniture are particularly prone to heat damage or discolouration at temperatures below the guidelines given above.
- Any damage caused by the appliance being installed in contravention of this temperature limit, or by placing adjacent cabinet materials closer than 4mm to the appliance, **will be the liability of the owner.**
- For use in **leisure accommodation vehicles**, please refer to the appropriate information given in the installation instructions for this appliance.
- The use of this appliance for any other purpose or in any other environment without the express agreement of Baumatic Ltd. will invalidate any warranty or liability claim.
- Your new appliance is guaranteed against electrical or mechanical defects, subject to certain exclusions that are noted in Baumatic's Conditions Of Guarantee. The foregoing does not affect your statutory rights.
- **Repairs may only be carried out by Baumatic Service Engineers or their authorised service agent.**

## Warning and safety instructions

- This appliance complies with all current European safety legislation. Baumatic do wish to emphasise that this compliance does not remove the fact that the appliance surfaces **will become hot during use and retain heat after operation.**

## Child Safety

- Baumatic strongly recommend that babies and young children are prevented from being near to the appliance and not allowed to touch the appliance **at any time.**
- If it is necessary for younger family members to be in the kitchen, please ensure that they are kept under close supervision at all times.

## General Safety

- **Do not** place heavy objects on the oven door or lean on the oven door when it is open, as this can cause damage to the oven door hinges.
- **Do not** leave heated oil or fat unattended, as this is a fire risk.
- **Do not** place pans or baking trays directly on the base of the oven cavity, or line it with aluminium foil.
- **Do not** allow electrical fittings or cables to come into contact with areas on the appliance that get hot.
- **Do not** use the appliance to heat the room it is located in or to dry clothing.
- **Do not** install the appliance next to curtains or soft furnishings.
- **Do not** attempt to lift or move cooking appliances by using the oven door or handle, as this may cause damage to the appliance or result in injury to the person lifting the appliance.

## Cleaning

- Cleaning of the oven should be carried out on a regular basis.
- Great care should be taken whilst using this appliance and when following the cleaning procedure.
- **IMPORTANT:** The appliance must be disconnected from the mains before following the cleaning procedure.

## Installation



**This appliance must be correctly installed by a suitably qualified person, strictly in accordance with the manufacturer's instructions.**

- **Baumatic Ltd. declines any responsibility for injury or damage, to person or property, as a result of improper use or installation of this appliance.**
- Heat, steam and moisture will be created during use of the appliance, take care to avoid injury and ensure that the room is adequately ventilated. If the appliance is going to be used for prolonged periods of time, then additional ventilation may be required.
- Please consult with your qualified installer if you are in any doubt about the amount of ventilation that you will require.

### **Declaration of conformity**

- In the parts destined to come into contact with foodstuffs, this appliance is in accordance with the requirements of the EC directive 89/109 transposed in the Italian Legislative Decree No. 108 of 25/01/92.
- **CE:** Appliance conforming to the European directives 89/336/EEC, 93/68/EEC, 73/23/EEC and subsequent revisions and "RoHS" directive 2002/95/CE.\*
- The manufacturer declares that the oven is built using certified materials and requires the appliance to be installed in accordance with the standards currently in force. This appliance must be used by a trained person for domestic purposes only.

- \* The RoHS directive stands for "the restriction of the use of certain hazardous substances in electrical and electronic equipment". This directive bans the placing on the EU market of new electrical and electronic equipment containing more than the agreed levels of lead, cadmium, mercury, hexavalent chromium, polybrominated biphenyl (PBB) and polybrominated diphenyl ether (PBDE) flame retardants.

## Specifications

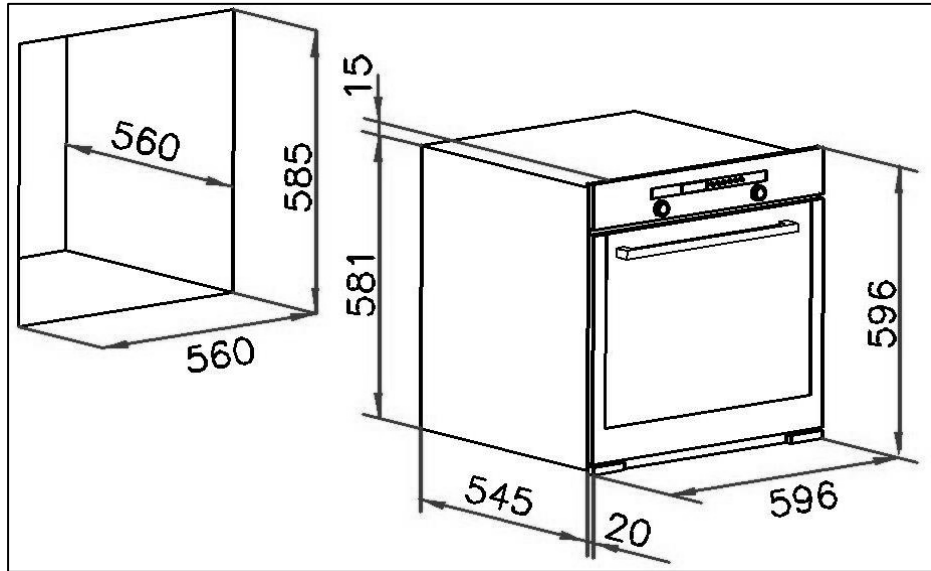

### Product Dimensions

Height: 596 mm  
Width: 596 mm  
Depth: 545 mm

### Aperture Dimensions

Height: 585 mm  
Width: 560 mm  
Depth: 560 mm

### Product specifications

- 9 functions
- Energy efficiency class: A
- Oven capacity: 65 litres
- LED full programmer
- Cooling fan
- Thermostatically controlled grill
- Wipeclean enamel cavity
- Flush mounted installation
- Triple-glazed removable door

### Standard accessories:

- Removable roof liner
- Removable side racks
- 2 x safety shelves
- Wipeclean enamelled drip tray with handle
- Trivet



**Optional extras:**

- BPS1 Pizza stone
- TEL4KIT Telescopic runners kit

**Cooling fan**

- A tangential cooking fan is fitted inside of this appliance, to make the internal temperature of the oven stable and the external surface temperature lower.

**Electrical details**

<b>Rated Voltage:</b>	230 Vac 50 Hz
<b>Supply Connection:</b>	16 A (double pole switched fused outlet with 3mm contact gap)
<b>Max Rated Inputs:</b>	3.6 kW
<b>Mains Supply Lead:</b>	3 x 1.5 mm <sup>2</sup>
<b>Oven Light Bulb:</b>	25 W/300°C screw type pigmy

For future reference please record the following information which can be found on the rating plate and the date of purchase which can be found on your sales invoice. The rating plate for your oven can be located by opening the oven door and looking on the right hand side of the oven chassis.

**Model Number** .....

**Serial Number** .....

**Date of Purchase** .....

## Control Panel

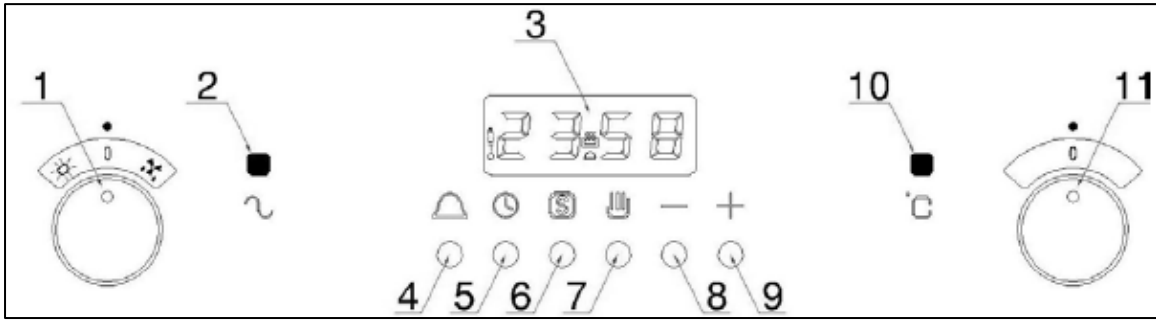

- 1) Oven function selector knob
- 2) Power indicator light
- 3) Oven programmer/timer
- 4) Timer "minute minder" button
- 5) Timer "duration" button
- 6) Timer "end cook" button
- 7) Timer "manual operation" button
- 8) Timer "minus" button
- 9) Timer "plus" button
- 10) Oven operating light
- 11) Thermostat control knob

### Oven programmer/timer display

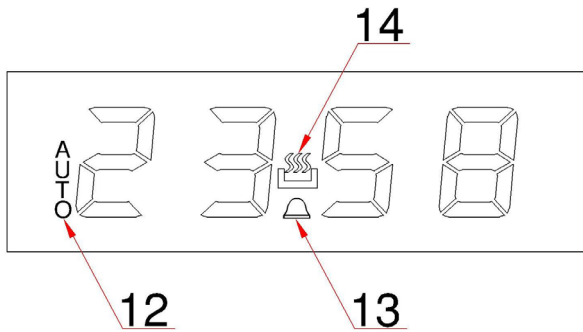

- 12) "Auto" function symbol
- 13) "Minute minder" symbol
- 14) "Manual operation" symbol.

## Setting and using the oven programmer/timer

### Selecting manual operation mode

**After your appliance is connected to your mains supply for the first time, the numbers on the timer display will flash. Before you can select a cooking function or set a temperature, you must set the appliance into "manual operation" mode.**

- To select manual operation mode, press the "manual operation" button **(7)** on the control panel.

### Setting the time of day

***After setting your oven for manual operation, you should also set the time of day.***

- Use the "minus" button **(8)** and "plus" button **(9)** to adjust the time that appears in the display. After getting the display to the correct time, release the "minus" and "plus" buttons. After a few seconds the time will fix in the display and you will be able to use your oven.

### Before first use

- To remove any residue from the oven that may have been left from the manufacturing process, you should select either the fan or conventional oven function and turn the thermostat dial to its maximum temperature setting.
- It is perfectly normal for a smell to be produced during this process.
- You should make sure that any windows in the room are left open during this process.
- It is advisable for you not to remain in the room whilst the burning off process is taking place.
- You should leave the oven on maximum setting for 30 – 40 minutes.

## Setting the minute minder function

***You are able to set the minute minder at any time, regardless of whether an oven function has been selected. You can set a period of time using the minute minder function and an alarm will sound when this period of time has elapsed.***

- Press the "minute minder" button **(4)**, the display will show a value of 00:00. Set the period of time that you wish the minute minder to countdown for, by using the "minus" **(8)** and "plus" **(9)** buttons.
- Once the display has got to your desired countdown time, let go of the "minus" and "plus" buttons. The minute minder symbol **(13)** will appear on the timer display.
- Once a countdown time has been set, it is possible to shorten or lengthen the time by using the "minus" or "plus" buttons.
- An alarm will sound when the countdown time has elapsed. The alarm can be silenced by pressing the "minute minder" button.
- **Important:** The oven will continue to heat once the alarm has been silenced. If you have finished cooking, then you should turn the oven function selector and thermostat control knob to 0.

## Setting the duration function

***This function will allow you to set a countdown time similar to the minute minder function. However the oven will no longer continue to heat, once the countdown period has elapsed.***

- Use the thermostat control knob **(11)** to set the temperature that you require. The manual operation symbol **(14)** will appear on the display.
- Use the oven function selector knob **(1)** to select the mode of cooking that you require.
- It is then possible to set the duration of the cooking time that you require.
- Press the "duration" button **(5)** and the display will show a value of 00:00. Set the period of time that you wish the duration function to countdown for, by using the "minus" **(8)** and "plus" **(9)** buttons.
- Once the display has got to your desired countdown time, let go of the "minus" and "plus" buttons. The countdown will start immediately and the word AUTO will appear on the timer display.
- Once a countdown time has been set, it is possible to shorten or lengthen the time by using the "minus" or "plus" buttons.
- An alarm will sound when the countdown time has elapsed and the oven will switch off. The word AUTO will flash and the heating symbol will disappear. The alarm can be silenced by pressing the "duration" button.
- You will need to return the oven to manual operation mode, once the duration function has been used. To do this you should press the "manual operation" button, the word AUTO will disappear from the display and the manual operation symbol will appear instead.
- **Important:** If you do not turn the thermostat control knob and oven function selector knob to 0. Then the appliance will continue to operate as soon as you press the "manual operation" button.

## Setting the end cook function

***This function is similar to the duration function, however instead of selecting a period of time that you wish the oven to switch off after. You select the time of day that you wish the oven to switch off at.***

- Use the thermostat control knob **(11)** to set the temperature that you require. The manual operation symbol **(14)** will appear on the display.
- Use the oven function selector knob **(1)** to select the mode of cooking that you require.
- Press the "end cook" button **(6)** and the display will show a value of 00:00. Set the time of day that you wish the oven to stop cooking at by using the "minus" and "plus" buttons. The timer will calculate how long the cooking time will be, based on the time of day that you have selected and show it on the display.
- Once the display has got to the time of day that you want the oven to stop cooking at, let go of the "minus" and "plus" buttons. The countdown will start immediately and the word AUTO symbol will appear on the timer display.
- When the time is set, it can be modified by pressing the "minus" and "plus" buttons.
- When the time of day reaches the end of cooking time that you set, the oven will switch off and an alarm will sound. The word AUTO will flash and the heating symbol will disappear. The alarm can be silenced by pressing the "end cook" button.
- You will need to return the oven to manual operation mode, once the end cook function has been used. To do this you should press the "manual operation" button, the word AUTO will disappear from the display and the manual operation symbol will appear instead.
- **Important:** If you do not turn the thermostat control knob and oven function selector knob to 0. Then the appliance will continue to operate as soon as you press the "manual operation" button.

## Setting the start and end time function

***This function will allow you to set a time in the future that the oven switches on at and a time that the oven will switch off at.***

- Use the thermostat control knob **(11)** to set the temperature that you require. The manual operation symbol **(14)** will appear on the display.
- Use the oven function selector knob **(1)** to select the mode of cooking that you require.
- Press the "duration" button **(5)** and the display will show a value of 00:00. Set the period of time that you wish to cook for, by using the "minus" **(8)** and "plus" **(9)** buttons. The word AUTO will appear on the timer display.
- **Immediately** press the "end cook" button **(6)** and the timer display will show the value 00:00. Set the time of day that you want the oven to switch off at, using the "minus" and "plus" buttons.
- The oven will calculate what time it needs to switch on at, so that your food will cook for the length of time that you selected. It will automatically switch itself on, once it reaches the time of day that it has calculated.
- When the time of day reaches the end of cooking time that you set, the oven will switch off and an alarm will sound. The word AUTO will flash and the heating symbol will disappear. The alarm can be silenced by pressing the "end cook" or "duration" button.
- You will need to return the oven to manual operation mode, once the start and end time function has been used. To do this you should press the "manual operation" button, the word AUTO will disappear from the display and the manual operation symbol will appear instead.
- **Important:** If you do not turn the thermostat control knob and oven function selector knob to 0. Then the appliance will continue to operate as soon as you press the "manual operation" button.

## Selecting a cooking function and temperature

### Selecting manual operation mode

**After your appliance is connected to your mains supply for the first time, the numbers on the timer display will flash. Before you can select a cooking function or set a temperature, you must set the appliance into "manual operation" mode.**

- To select manual operation mode, press the "manual operation" button **(7)** on the control panel.

### Selecting an oven function

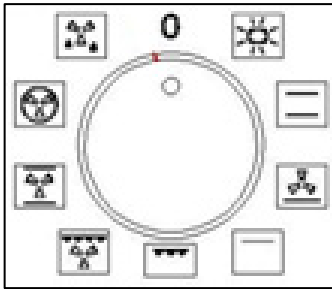

The oven function selector knob should be used to select the particular mode of cooking that you require. The appliance will utilise different elements within the oven cavity, depending on the oven function that you select. When a function is selected, the power indicator light will come on.

### There are nine cooking functions available on your appliance:

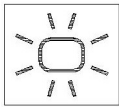

**OVEN LIGHT:** Separate light control which allows the light to be switched on, even when the oven is switched off.

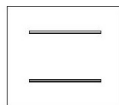

**CONVENTIONAL OVEN (top and lower element):** This method of cooking provides traditional cooking, with heat from the top and lower elements. This function is suitable for roasting and baking on one shelf only.

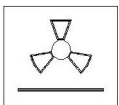

**FAN AND LOWER ELEMENT:** This method of cooking utilises the bottom element in conjunction with the fan, which helps to circulate the heat. This function is suitable for sterilizing and preserving jars.

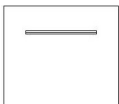

**TOP ELEMENT ONLY:** This method of cooking uses the outer part of the top element to direct heat downwards onto the food. For gentle cooking, browning or keeping cooked dishes warm.



**GRILL MODE:** This method of cooking utilises the inner and outer sections of the top element, which directs heat downwards onto the food. This function is suitable for grilling medium or large portions of sausages, bacon, steaks, fish etc.



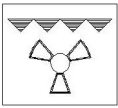

**FAN AND GRILL:** This method of cooking utilises the top element in conjunction with the fan, which helps to provide a quick circulation of heat. This function is suitable where quick browning is required and “sealing” the juices in, such as steaks, hamburgers, some vegetables etc.

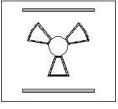

**CONVENTIONAL OVEN & FAN:** This method of cooking provides traditional cooking with heat from the top and bottom element. It also switches on the circulation fan which helps to ensure fast, even distribution of the heat. This function is suitable for light and delicate baking such as pastries. You can cook on different shelf levels, as long as the food being cooked requires the same cooking temperature.

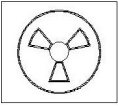

**FAN OVEN:** This method of cooking uses the circular element while the heat is distributed by the fan. This results in a faster and more economical cooking process. The fan oven allows food to be cooked simultaneously on different shelves, preventing the transmission of smells and tastes from one dish onto another.

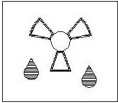

**DEFROST MODE:** The fan runs without heat to reduce the defrosting time of frozen foods. The time required to defrost the food will depend on the room temperature, the quantity and type of food. Always check food packaging for the defrosting instructions.

### Thermostat control knob

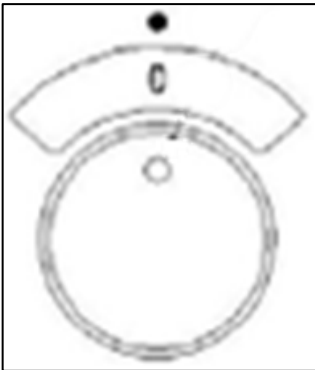

The oven thermostat control knob sets the required temperature of the oven. It is possible to regulate the temperature within a range of 50 - 250°C.

**Turn the control knob clockwise.**

### Oven operating light

This light will come on to indicate that the oven’s heating elements are in operation. The light will turn off when the temperature set on the thermostat control knob has been reached. It will cycle on and off throughout the cooking time.

**You should not place food inside the cavity, until the correct cooking temperature has been reached.**

## Cooking guidelines

- Please refer to the information given on food packaging for guidance on cooking temperatures and times. Once familiar with the performance of your appliance, temperatures and times can be varied to suit personal preference.
- If you are using the fan oven function, then you should follow the information given on the food packaging for this particular mode of cooking.
- You should pre-heat the oven and not place food inside of it until the oven operating light has gone off. You can choose not to pre-heat when using the fan oven mode; however you should extend the cooking time given on the food packaging by at least ten minutes.
- **IMPORTANT:** You should pre-heat the oven if you are baking, regardless of whether you are using the conventional oven or fan oven functions.
- If there is no guidance given on the food packaging specifically for cooking in fan oven mode, you can generally reduce the cooking time and temperature by 10% from the information given for conventional oven cooking.
- Make sure that frozen foods are thoroughly thawed before cooking, unless the instructions on the food packaging advise that you can “cook from frozen”.
- Before cooking, check that any accessories that are not required are removed from the oven.
- Place cooking trays in the centre of the oven and leave gaps between the trays to allow air to circulate.
- Try to open the door as little as possible to view the dishes.
- The oven light will remain on during cooking.

## Warnings

- Keep the oven door closed when using any of the grill functions.
- Do not use aluminium foil to cover the grill pan or heat items wrapped in aluminium foil under the grill. The high reflectivity of the foil could potentially damage the grill element.

- You should also never line the base of your oven with aluminium foil.
- During cooking, never place pans or cookware directly onto the bottom of your oven. They should always be placed on the shelves provided.
- The grill heating element and other internal components of the oven become extremely hot during operation, avoid touching them inadvertently when handling the food which you are grilling.
- **Important:** Be careful when opening the door, to avoid contact with hot parts of the oven and steam.
- The drip tray handle should only be used to reposition the drip tray and **NOT** for removing it from the oven cavity. When removing the drip tray, you should **ALWAYS** use an oven glove.
- The drip tray handle should not be left in position when the appliance is switched on.
- **Warning:** Accessible parts may become hot during use. Young children should be kept well away from the oven when it is in use.

## Accessories

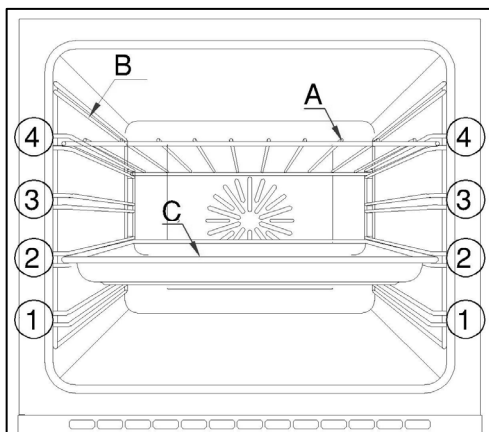

Your oven will come supplied with the following oven furniture:

- 2 safety shelves **(A)**
- Removable side racks, which allow you to cook on four different levels **(B)**
- 1 drip tray **(C)**
- 1 handle for the drip tray

The numbers 1 – 4, indicate the different shelf positions that you can utilise within the oven.



**Cleaning operations must only be carried out when the oven is cool.**

**The appliance should be disconnected from your mains supply before commencing any cleaning process.**

- The oven should be thoroughly cleaned before it is operated for the first time and after each use. This will avoid residual food stuffs becoming baked on the oven cavity. After residues have been baked on several times, they are far more difficult to remove.
- **Never** clean the oven surfaces by steam cleaning.
- The oven cavity should only be cleaned with warm soapy water, using either a sponge or soft cloth. No abrasive cleaners should be used.
- Any stains that may appear on the bottom of the oven will have originated from food splashes or spilt food, these splashes occur during the cooking process. These could possibly be a result of the food being cooked at an excessively high temperature or being placed in cookware that is too small.
- You should select a cooking temperature and function that is appropriate for the food that you are cooking. You should also ensure that the food is placed in an adequately sized dish and that you use the drip tray where appropriate.
- Outer parts of the oven should only be cleaned with warm soapy water, using either a sponge or soft cloth. No abrasive cleaners should be used.
- If you use any form of oven cleaner on your appliance, then you must check with the manufacturer of the cleaner that it is suitable for use on your appliance.
- Do not use harsh abrasive cleaners or metal scrapers to clean the oven door glass as this can scratch the surface, which may result in the oven glass shattering.
- **Any damage that is caused to the appliance by a cleaning product will not be fixed by Baumatic free of charge, even if the appliance is within the guarantee period.**

## Removable oven roof liner

- Your appliance is supplied with a roof liner, which should be slid over the top of the grill element.
- Once you have finished cooking, the liner should be removed and thoroughly cleaned after each use of the appliance.
- **Do not** allow fat and grease to build up on the oven liner, as this could cause a fire hazard.

## Replacing the oven bulb



**IMPORTANT: The oven must be disconnected from your mains supply before you attempt to either remove or replace the oven bulb.**

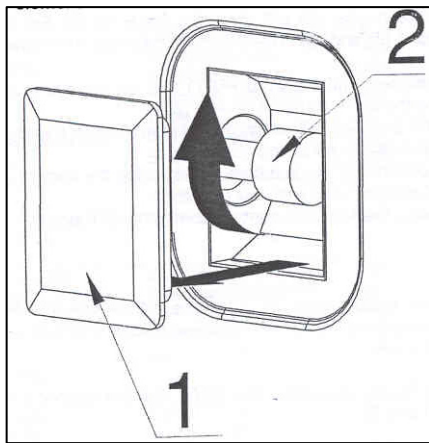

- Remove all oven shelves, the drip tray and the side rack that is on the same side as the oven light.
  - Using a screwdriver, remove the lamp cover (1).
  - Unscrew the bulb (2) clockwise and remove it from its holder.
- 
- Replace the bulb with a 25 W/300°C, screw type pigmy.
  - **Do not** use any other type of bulb.
  - Place the lamp cover back into position. There is a curve on one side of the cover; this should be on the right hand side as the cover goes back into place.

## Removing the oven door for cleaning

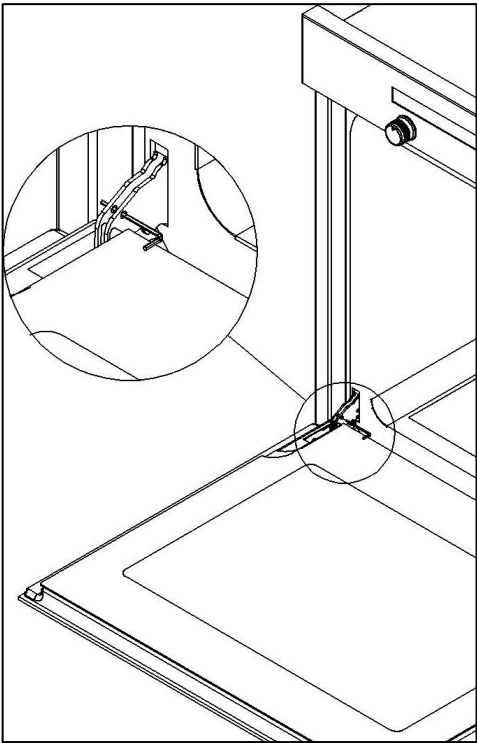

To facilitate the cleaning of the inside of the oven and the outer frame of the oven, the door can be removed as follows:-

- Open the oven door completely.
  - Insert an allen key into the hinge holes in the left hand hinge. This stops it from rotating as you remove the door.
  - Make sure that the allen key is fully inserted through both of the holes in the left hand hinge before attempting to remove the door.
- 
- You should grip the sides of the door at the centre and then incline it towards the oven cavity until you feel resistance. Then you should lift the door gently away until the hinge disengages from the oven cavity.
  - **IMPORTANT:** You should make sure that the door is supported at all times and that you place the door on some padded material whilst cleaning it.
  - The oven door and door glass should only be cleaned using a damp cloth and a small amount of detergent. The cloth **MUST NOT** have come into contact with any form of cleaning product or chemical previously.
  - To refit the door you should follow the procedure given above in reverse.
  - **IMPORTANT:** You should ensure that the oven door opens and shuts correctly before using the oven again.



**Do not immerse the door in water at any time.**

## INSTALLATION



**The installation must be carried out by a suitably qualified person, in accordance with the current version of the following.**

- UK Regulations and Safety Standards or their European Norm Replacements.
- **Building Regulations** (issued by the Department of the Environment).
- **Building Standards** (issued by the Scottish Development Department).
- **IEE Wiring Regulations.**
- **Electricity At Work Regulations.**

Before connecting the appliance, make sure that the supply voltage marked on the Rating Plate corresponds with your mains supply voltage.

### **WARNING: THIS APPLIANCE MUST BE EARTHED.**

- This appliance should be wired into a 16 A double pole switched fused spur outlet, having 3 mm contact separation and placed in an easily accessible position adjacent to the appliance. The spur outlet must still be accessible even when your oven is located in its housing.

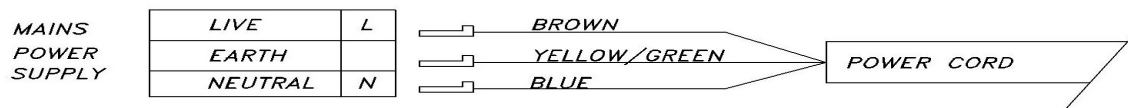

- To connect the oven power cord, loosen and remove the cover on the terminal block, in order to gain access to the contacts inside. Make the connection, securing the cord in place with the cable clamp provided and then immediately close the terminal block cover again.
- If you have to change the oven power cord, the earthing (yellow/green) conductor must always be 10 mm longer than the line conductors.
- Care must be taken to ensure that the temperature of the mains supply cable does not exceed 50°C.
- If the mains supply cable is damaged, then it must be replaced by an appropriate replacement which can be obtained from the Baumatic Spares Department.

## Installing the oven into the kitchen cabinet

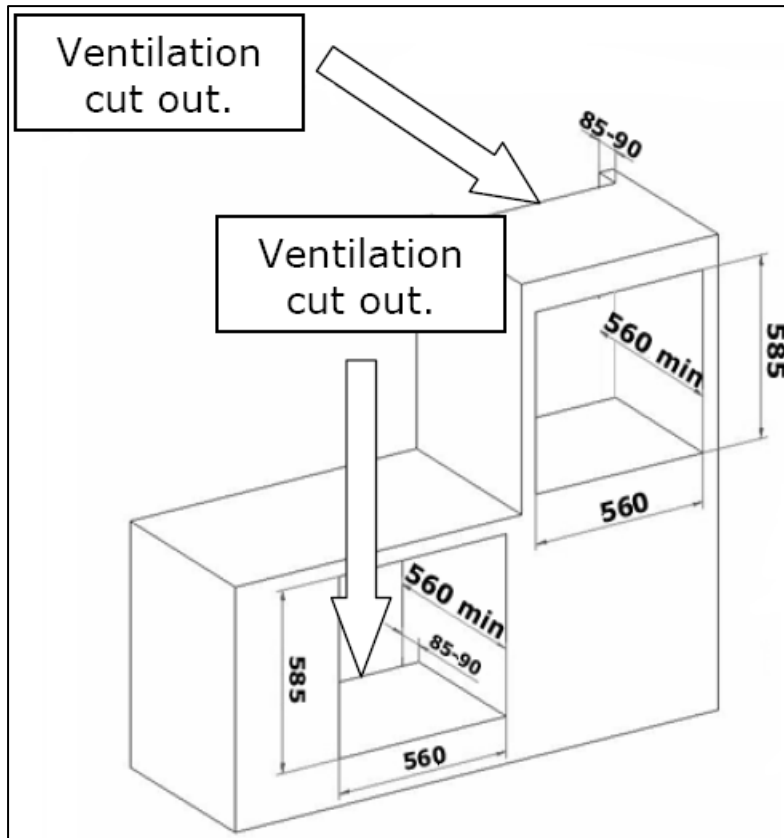

### Fixing the oven into a cabinet.

- Ensure that the aperture that you will be fitting the oven into is of the size given in the above diagram.
- Ensure that the rear panel of the furniture housing unit has been removed.
- This oven may be installed without any additional ventilation cut outs being made in the housing unit. However the ventilation cut out indicated by the arrow in the above picture **MUST** be present, otherwise the oven may overheat. This applies to a built in or built under installation.



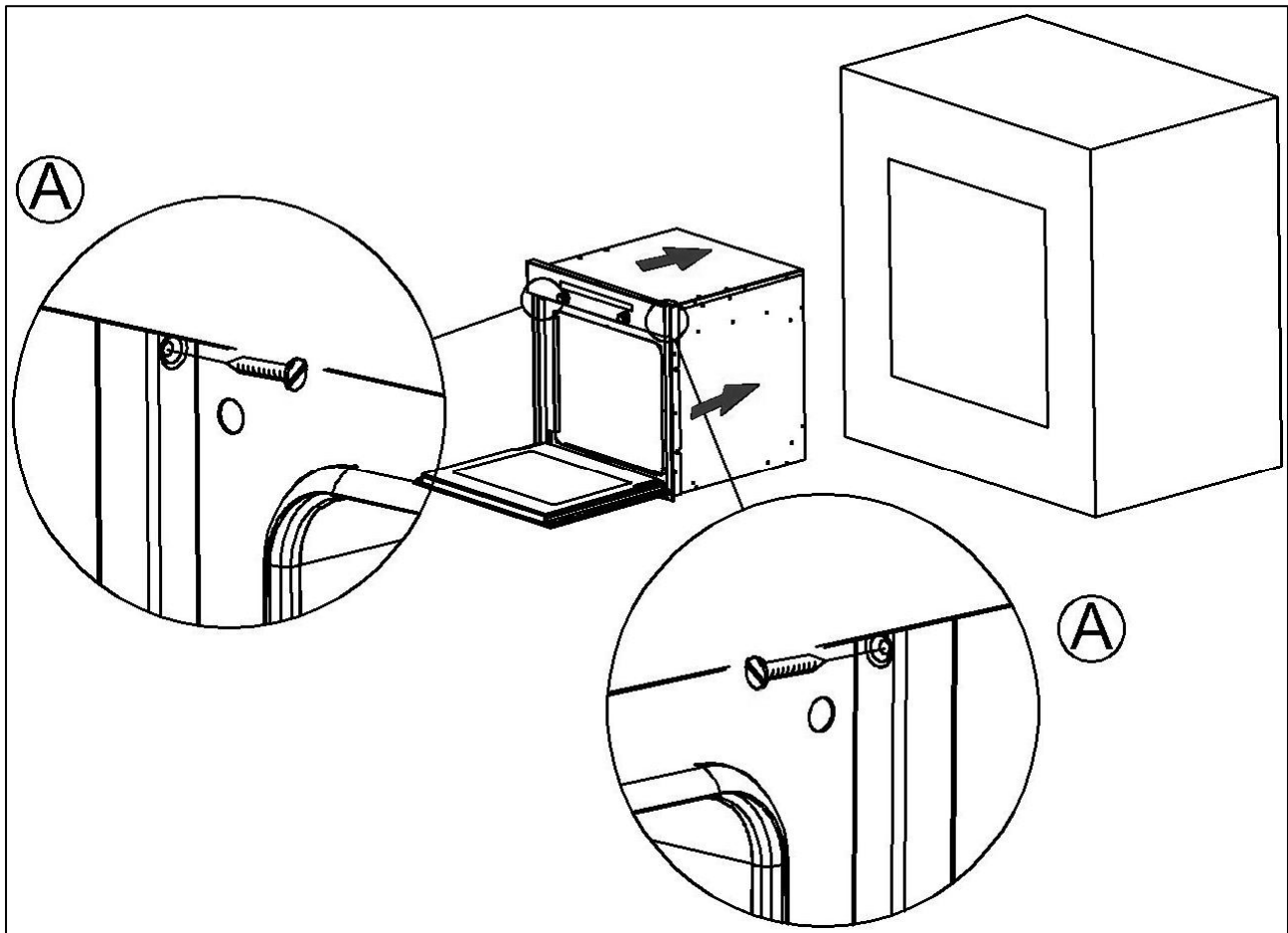

- Ensure that the oven has been securely fixed into the housing unit. The fixing of the oven into the housing is made by using four screws. These should be screwed through the oven cabinet and into the housing unit.

### My appliance isn't working correctly

- **The oven isn't coming on.**
  - \* Check that the oven is in manual operation mode.
  - \* Check that you have selected a cooking function and a cooking temperature.
- **There appears to be no power to the oven and grill.**
  - \* Check that the appliance has been connected to the electrical mains supply correctly.
  - \* Check that the mains fuses are in working order.

- \* Check that the operating instructions for setting the time of day and putting the appliance into manual operation mode have been followed.
- **The grill function works but the main oven does not.**
- \* Check that you have selected the correct cooking function.
- **The grill and top oven element is not working, or cuts out for long periods of time during use.**
- \* Allow the oven to cool for approximately 2 hours. Once cool, check whether the appliance is again working properly.
- **My food is not cooking properly**
- \* Ensure that you are selecting the correct temperature and the correct cooking function for the food that you are cooking. It may be appropriate to adjust your cooking temperature by plus or minus 10°C, to achieve the best cooking results.
- **My food is not cooking evenly**
- \* Check that the oven has been installed correctly and is level.
- \* Check that the correct temperatures and shelf positions are being used.
- **The oven light is not working**
- \* Refer to page 21 and follow the "Replacing the oven bulb" section.
- **I am getting condensation in my oven**
- \* Steam and condensation is a natural by product of cooking any food with high water content, such as frozen food, chicken etc.
- \* You may get condensation in the oven cavity and forming between the oven door glasses. This is not necessarily a sign that the oven is not working correctly.
- \* Do not leave food in the oven to cool after it has been cooked and the oven has been switched off.
- \* Use a covered container, where practical, when cooking to reduce the amount of condensation that forms.



**IMPORTANT: If your appliance appears not to be operating correctly, then you should disconnect it from your mains supply and then contact the Baumatic Service Department on telephone number (0118) 933 6911.**

**DO NOT ATTEMPT TO REPAIR THE APPLIANCE YOURSELF.**

Please note that if an engineer is asked to attend whilst the product is under guarantee and finds that the problem is not the result of an appliance fault, then you may be liable for the cost of the call out charge.

**The appliance must be accessible for the engineer to perform any necessary repair. If your appliance is installed in such a way that an engineer is concerned that damage will be caused to the appliance or your kitchen, then he will not complete a repair.**

**This includes situations where appliances have been tiled in, sealed in with sealant, have wooden obstructions placed in front of the appliance, like plinths. Or any installation other than the one specified by Baumatic Ltd. has been completed.**

Please refer to the conditions of guarantee that appear on the warranty card that you receive with the appliance.



*You will be mine ...*

**United Kingdom**

Baumatic Ltd.,  
Baumatic Buildings,  
6 Bennet Road,  
Reading, Berkshire  
RG2 0QX  
United Kingdom

**Sales Telephone**

(0118) 933 6900

**Sales Fax**

(0118) 931 0035

**Service Telephone**

(0118) 933 6911

**Service Fax**

(0118) 986 9124

**Spares Telephone**

(01235) 437244

**Technical Advice Telephone**

(0118) 933 6933

**E-mail:**

sales@baumatic.co.uk  
technical@baumatic.co.uk

**Website:**

www.baumatic.co.uk

**Republic of Ireland**

01- 6266 798

**Czech Republic**

Baumatic CR spol s.r.o.  
Amperova 495  
46215, Librec  
Czech Republic

+420 800 185 263

www.baumatic.cz

**Slovak Republic**

Baumatic Slovakia, s.r.o.  
Skultetyho 1  
831 04 Bratislava 3  
Slovakia

+421 255 640 618

**Germany**

Baumatic Gmbh  
Janderstrasse 9  
Mannheim, 68199  
Germany

+4962 112 9190

www.baumatic.de

**Italy**

Baumatic Italia S.R.L.  
Via Caltana 129  
Campodarsego (Padova), 35011  
Italy

+3904 9920 2297

www.baumatic.it

**Holland**

Baumatic Benelux B.V.  
Grindzuigerstraat 22  
1333 MS ALMERE  
The Netherlands

+3136 549 1555

www.baumatic.nl









**Baumatic®**

[www.baumatic.com](http://www.baumatic.com)