

BHC606BE
60cm touch control
ceramic hob

Instruction manual



User Manual for your Baumatic

BHC606BE

60 cm Front touch control
4 zone ceramic hob.



Baumatic®

You will be mine ...

NOTE: This User Instruction Manual contains important information, including safety & installation points, which will enable you to get the most out of your appliance. Please keep it in a safe place so that it is easily available for future reference; for you or any person not familiar with the operation of the appliance.

DD 11/11/08

Contents

Environmental note	4
Important safety information	5 – 8
Specifications	8 – 10
Ceramic hob layout	9
Control panel layout	10
Using the ceramic hob	10 - 16
Before first use	10
Touch controls	10
Switching the hob top on	11
Switching on a zone and setting a power level	11
Switching off a zone	11
Switching off the hob	12
Residual heat indicator	12
Switching on the dual cooking zone	12 - 13
Locking the hob top	14
The hob timer	14 – 15
Setting a countdown time	15
Safety cut-off	16
Hob guidelines	16 – 17
Cleaning and maintenance	18 - 19
Cleaning the ceramic hob top	18
After each use	18
Cleaning table	18
Using a ceramic hob scraper	19
Using a specialist ceramic hob cleaner	19
Installation	19 - 25
Positioning	20
Unpacking the appliance	20
Installing the appliance	21 – 22
Electrical connection	23
Connecting the mains supply cable	23 - 24
Replacing the mains supply cable	25
My appliance isn't working correctly	25 - 26
Contact details	27

This appliance is marked according to the European directive 2002/96/EC on Waste electrical and Electronic Equipment (WEEE). By ensuring this product is disposed of correctly, you will help prevent potential negative consequences for the environment and human health, which could otherwise be caused by inappropriate waste handling of this product.

The symbol  on the product, or on the documents accompanying the product, indicates that this appliance may not be treated as household waste. Instead it shall be handed over to the applicable collection point for the recycling of electrical and electronic equipment.

Disposal must be carried out in accordance with local environmental regulations for waste disposal.

For more detailed information about treatment, recovery and recycling of this product, please contact your local city office, your household waste disposal service or the shop where you purchased the product.



- The packaging materials that Baumatic uses are environmentally friendly and can be recycled.
- Please discard all packaging material with due regard for the environment.

Important safety information



Your safety is of the utmost importance to Baumatic. Please make sure that you read this instruction booklet **before** attempting to install or use the appliance. If you are unsure of any of the information contained in this booklet, please contact the Baumatic Advice Line.

General Information

- This appliance is designed for domestic household use and for the cooking and frying of domestic foodstuffs.
- **IMPORTANT:** The adjacent furniture and all materials used in the installation **must** be able to withstand a minimum temperature of 85°C above the ambient temperature of the room it is located in, whilst in use.
- Certain types of vinyl or laminate kitchen furniture are particularly prone to heat damage or discolouration at temperatures below the guidelines given above.
- Any damage caused by the appliance being installed in contravention of this temperature limit, **will be the liability of the owner.**
- Your new appliance is guaranteed against electrical or mechanical defects, subject to certain exclusions that are noted in Baumatic's Conditions Of Guarantee. The foregoing does not affect your statutory rights.
- The use of this appliance for any other purpose or in any other environment without the express agreement of Baumatic Ltd. will invalidate any warranty or liability claim.
- You should not use this appliance to store items on or as a work surface.
- No modifications to the appliance are permitted by Baumatic Ltd.
- You should not store or place flammable or highly flammable liquids/materials on top of or near the appliance. Items made from aluminium, plastic or plastic film should also be kept away from the appliance, as they may fuse to the surface.
- **Repairs may only be carried out by Baumatic Service Engineers or their authorised service agent.**

Child Safety

- Baumatic strongly recommend that babies and young children are prevented from being near to the appliance and not allowed to touch the appliance **at any time**. During and after use, all surfaces will become hot.
- If it is necessary for younger family members to be in the kitchen, please ensure that they are kept under close supervision at all times.
- Older children should only be allowed to utilise the appliance when supervised.

General Safety

- ✓ The appliance should only be installed and connected by a suitably qualified person.
- ✓ Care should be taken to ensure that the units and work surfaces that you build the appliance into, meet with the relevant standards.
- ✓ If you notice any scratches, splits or cracks in the ceramic glass, you should immediately switch off the appliance and disconnect it from your mains supply. Otherwise there is the risk of electric shock occurring.

During use

- ✓ Any film or stickers that are present on the hob surface when it is delivered should be removed before use.
- ✓ Care should be used when utilising the appliance, otherwise there is a risk of burns being caused.
- You should not allow the electrical connection cables to come into contact with the hob surface when it is hot or any hot cookware.
- If fat and oil overheats, then it can ignite extremely quickly. For this reason, when cooking with fat and oil the appliance should not be left unattended.
- ✓ Make sure that all of the cooking zones are switched off after use.

Cleaning

- Cleaning of the hob should be carried out on a regular basis.
- **IMPORTANT:** Before attempting to clean the appliance, it should be disconnected from the mains and allowed to cool.
- Great care should be taken whilst using this appliance and when following the cleaning procedure.
- You should not use a steam jet or any other high pressure cleaning equipment to clean the appliance.

Installation



This appliance must be correctly installed by a suitably qualified person, strictly in accordance with the manufacturer's instructions. Please see the specific section of this booklet that refers to installation.

- **Baumatic Ltd. declines any responsibility for injury or damage, to person or property, as a result of improper use or installation of this appliance.**

Declaration of conformity

This appliance complies with the following European Directives:

- 73/23/EEC dated 19/02/1973 Low Voltage Directive.
- 89/336/EEC dated 03/05/1989 EMC Directive inclusive of Amending Directive 92/31/EEC.
- 93/68/EEC dated 22/07/1993 CE Marking Directive.
- 89/109/EEC dated 25/01/1992 Materials that can touch food.
- The manufacturer declares that the hob is built using certified materials and requires the appliance to be installed in accordance with the standards currently in force. This appliance must be used by a trained person for domestic purposes only.

To avoid damaging your appliance

- The ceramic glass can be damaged by objects falling onto it.
- The ceramic glass edge can be damaged by knocks from cookware.
- Cast iron and cast aluminium cookware with damaged bases may scratch the ceramic surface if they are dragged across it.

- Pans should be lifted on and off the hob surface and not dragged.
- Cooking zones should not be switched on without cookware placed on it. Also the cookware should not be empty.

Specifications

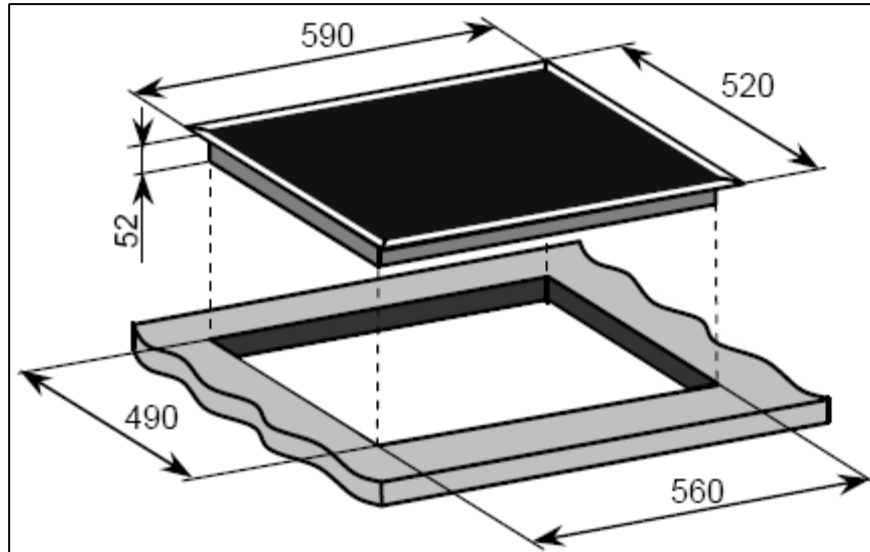

Product dimensions:

Height: 520 mm
 Width: 590 mm
 Depth: 52 mm

Aperture dimensions:

Height: 490 mm
 Width: 560 mm

Product specifications:

- 1 x 1.80 kW hyperspeed zone (diameter 180 mm)
- 2 x 1.20 kW hyperspeed zones (diameter 145 mm)
- 1 x 1.00/1.80 kW double hyperspeed zone (diameter 140/200 mm)
- Front touch control operation
- 4 individual residual heat indicators
- Safety lock
- Timer

Standard accessories

- Ceramic hob scraper

Electrical details

Rated Voltage:	230 Vac 50 Hz
Supply Connection:	30 A (double pole switched fused outlet with 3mm contact gap)
Max Rated Inputs:	6.4 kW
Mains Supply Lead:	3 core x 4 mm ² (not supplied)

For future reference please record the following information which can be found on the rating plate and the date of purchase which can be found on your sales invoice. The rating plate of your hob is located on the underneath of the appliance. Therefore it is a good idea to record this information before you install your appliance.

Model Number

Serial Number

Date of Purchase

Ceramic hob surface layout

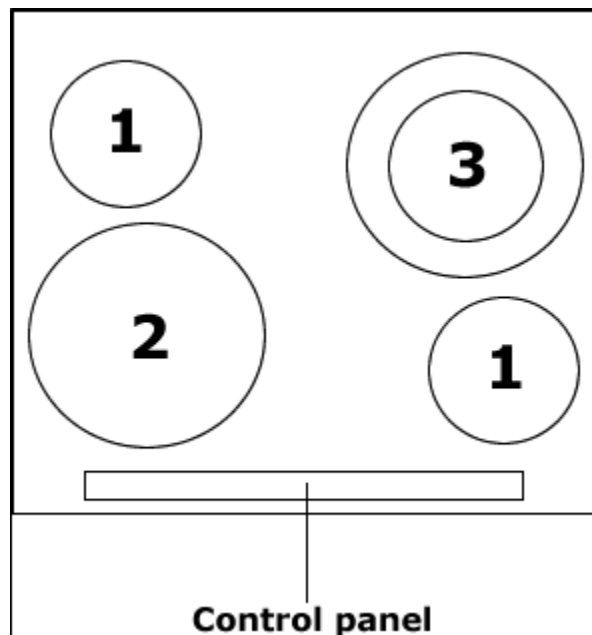

- 1) 1.20 kW hyperspeed zones (diameter 145 mm)
- 2) 1.80 kW hyperspeed zone (diameter 180 mm)
- 3) 1 x 1.00/1.80 kW double hyperspeed zone (diameter 140/200 mm)

Control panel layout

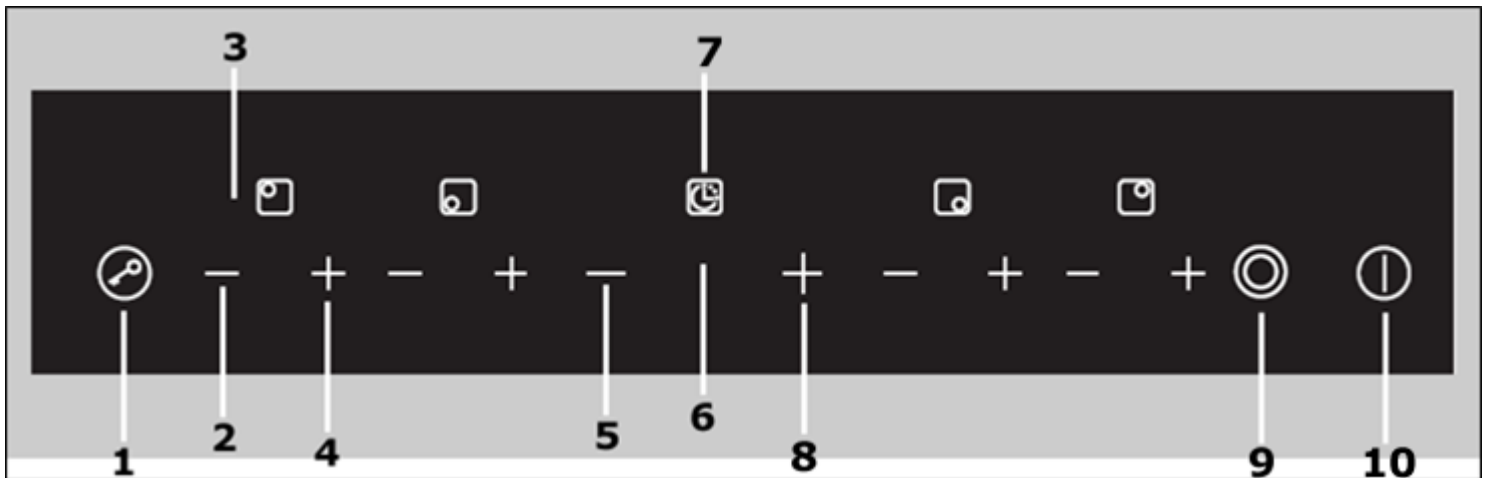

1. Safety lock button
2. Cooking zone minus button
3. Cooking zone indicator
4. Cooking zone plus button
5. Timer minus button
6. Timer display
7. Timer button
8. Timer plus button
9. Dual cooking zone ON/OFF button
10. ON/OFF button

Using the ceramic hob

Before first use



IMPORTANT: You should clean the ceramic hob surface (see "Cleaning and maintenance" section).

- You should switch on one cooking zone at a time, for 5 minutes at the maximum setting. This will help to eliminate any new smell that exists and evaporate any humidity that has formed on the heating elements during transit.
- Do not burn off more than one zone at once.
- **You must** place a saucepan filled half full with cold water on each zone as you burn it off.

Touch controls

- All operations are performed by means of the touch controls that can be found on the control panel.
- Each touch control has a visual display that corresponds to it.

Switching the hob top on

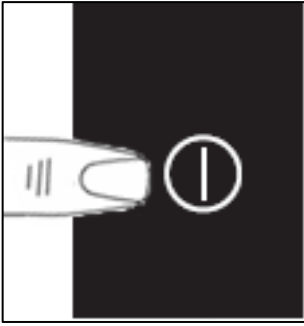

- Press the ON/OFF button **(10)** to switch on the appliance.
- The hob will beep once and all of the cooking zone indicators will light briefly then go out.

- This means that the hob has entered stand-by mode.

Switching on a zone and setting a power level

IMPORTANT: A zone must be selected within 2 minutes of switching the hob on.

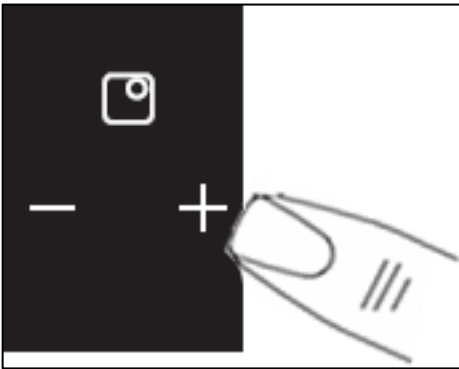

- Press the cooking zone plus button **(4)** of the zone that you want to use.

- Adjust the zone between power levels 1 and 9, using the plus **(4)** and minus **(2)** buttons. By holding down either of these buttons, the value on the zone indicator **(3)** will adjust up or down.

Switching off a zone

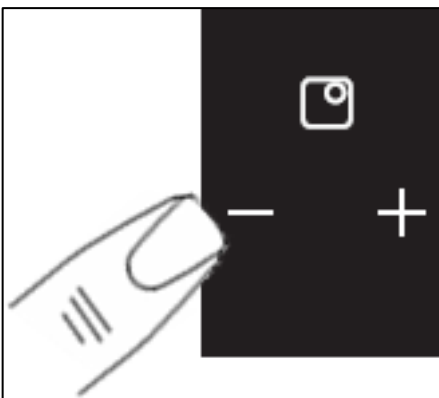

- Press the cooking zone minus button **(2)** of the zone that you want to switch off.
- Hold the button down until the number in the cooking zone indicator reaches "0". After a few seconds, the zone will switch off automatically.

- The letter "H" will show in the cooking zone indicator **(3)**, (see the section on the "residual heat indicator" on the next page).

Switching off the hob

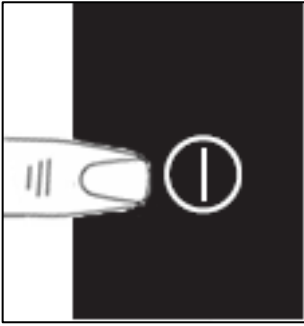

- Once you have switched off all of the cooking zones, you should turn off the hob.
- Press the ON/OFF button **(10)**.

- It is possible to turn the hob off at any time by pressing the ON/OFF button **(10)**.
- The hob will switch off automatically after 2 minutes, if none of the zones are in use.

Residual heat indicator

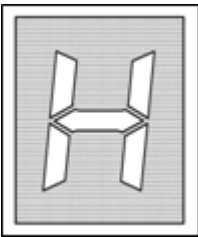

- After a zone is switched off, the corresponding cooking zone indicator **(3)** will show a flashing letter "H". This means that the temperature of the zone is over 60°C and is therefore still high enough to cause injury.
- When the temperature of the zone falls below 60°C, then the letter "H" will go out.
- **IMPORTANT:** The residual heat indicator will disappear if the mains supply to the product is cut.
- **IT IS STILL POSSIBLE TO BURN YOURSELF ON A HOB ZONE, EVEN WHEN THE TEMPERATURE OF IT HAS DROPPED BELOW 60°C.**

Switching on the dual cooking zone

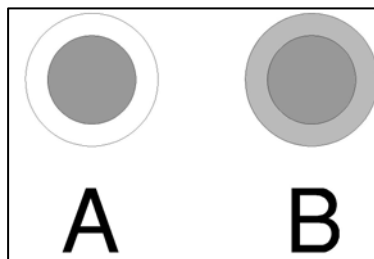

The dual cooking zone has two cooking areas that you can use a central section and an outer section. You can use the central section **(A)** independently or both sections **(B)** at once.

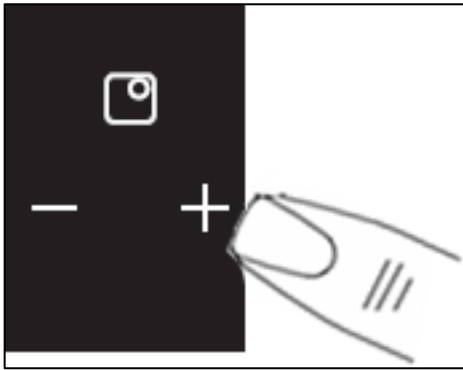

- Press the cooking zone plus button **(4)** for the dual circuit zone.

- Adjust the zone between power levels 1 and 9, using the plus **(4)** and minus **(2)** buttons. By holding down either of these buttons, the value on the zone indicator **(3)** will adjust up or down.
- The central section of the dual cooking zone will switch on.

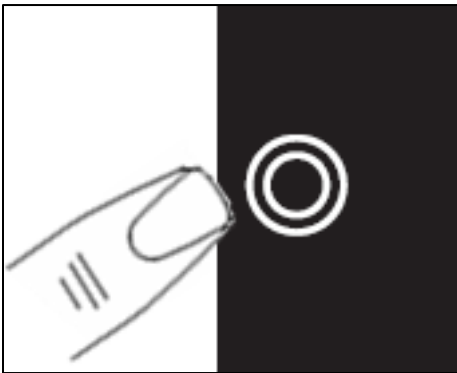

- If you wish to activate the outer section as well, you should press the dual cooking zone ON/OFF button **(9)**. A neon above the button will light.

- To switch the outer section off, you should press the dual cooking zone ON/Off button again. The neon above the button will go out and the outer section will go off.
- To switch off the zone after use, press the cooking zone minus button **(2)** of the dual cooking zone.
- Hold the button down until the number in the cooking zone indicator reaches "0". After a few seconds, the zone will switch off automatically.
- The letter "H" will show in the cooking zone indicator **(3)**.

Locking the hob top

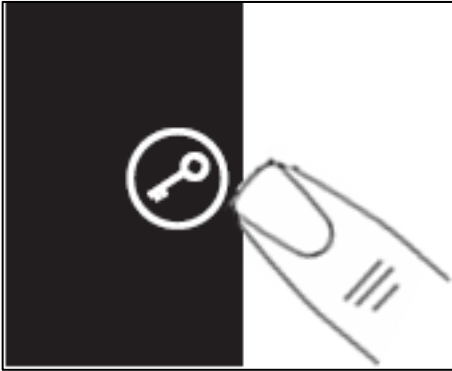

- The whole hob top can be locked by pressing the safety lock button **(1)** whilst the appliance is switched on.
- The timer display **(6)** will show "LO" to indicate that the safety lock feature has been activated.
- When the safety lock has been switched on, it will disable any of the other buttons on the control panel, apart from the ON/OFF button **(8)**.
- To disable the safety lock feature, you should press the safety lock button **(1)** again. The "LO" symbol will disappear from the timer display **(6)** and you are then able to adjust the power of any zone on the hob top.

The hob timer

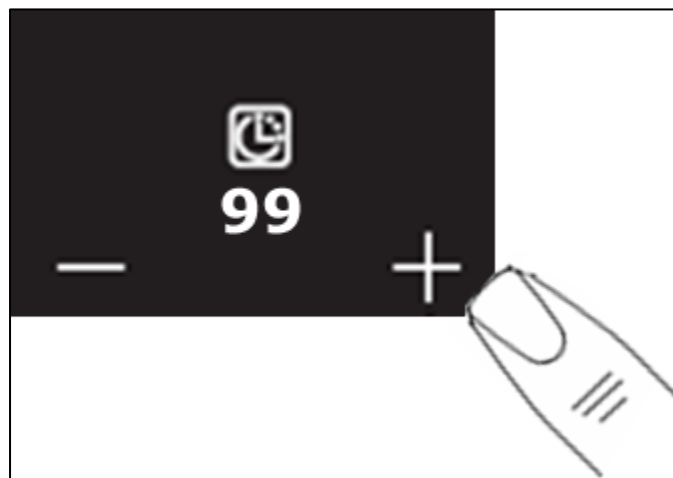

Your hob has a timer which will countdown a period of time between 1 and 99 minutes. At the end of the countdown period an audible signal will sound.

- Use the timer plus **(8)** and minus buttons **(5)** to set the countdown time.
- The timer display will show the countdown time that is being set.
- The timer display will increase in 1 minute intervals each time the timer plus button **(8)** is pressed.

- The timer display will decrease in 1 minute intervals each time the timer minus button **(5)** is pressed.
- If the set time exceeds 99 minutes, the timer display will return to showing 0.
- If you press the timer plus **(8)** and minus buttons **(5)** simultaneously, the timer display will reset to 0.

Setting a countdown time

- Press the ON/OFF button **(9)** to switch on the appliance.
- Press the cooking zone plus button **(4)** of the zone that you want to use.
- Adjust the zone between power levels 1 and 9, using the plus **(4)** and minus **(2)** buttons. By holding down either of these buttons, the value on the zone indicator **(3)** will adjust up or down.
- Press the timer button **(7)** and the timer display **(6)** will flash.
- Set the countdown time that you require, using the timer plus **(8)** and minus **(5)** buttons. Use the timer plus **(8)** and minus buttons **(5)** to set the countdown time.
- When the countdown time that you require appears on the timer, stop pressing the timer buttons.
- The timer display **(6)** will flash for 5 seconds, when it stops flashing; the countdown time will be set. Or you can press the timer button **(7)** again to confirm the countdown time.
- An audible signal will sound to advise you that the countdown period has elapsed.
- **WARNING: The zone will still remain active after the countdown period has elapsed. You will need to turn the hob zone off manually in the normal manner.**

Safety cut-off

- If one or more of the cooking zones are accidentally left on, a safety cut off will activate after a certain period of time. The length of time depends on the power level that a zone or zones have been set on.

LEVEL	TIME LIMIT (hours)
1	8
2	8
3	8
4	4
5	4
6	4
7	2
8	2
9	2

- If more than one zone is operating when one of the zones reaches its safety cut-off point, only the zone which has reached its safety cut off point will switch off.

Hob guidelines

- The first few times the hob top is used, it may give off an acrid, burning smell. This smell will disappear completely with repeated use.
- The worktop is fitted with cooking areas of different diameter and power.
- The positions where the heat will radiate from are clearly marked on the hob top. The saucepans must be positioned exactly on these zones for efficient heating to occur. Pans should have the same diameter as the cooking zone that they are being used on.
- You should not use saucepans with rough bottoms, as this can scratch the ceramic surface.
- Before use, make sure that the bottoms of the saucepans are clean and dry.
- When cold, the bottom of the pans should be slightly concave, as they expand when hot and lie flat on the surface of the hob. This will allow the heat to transfer more easily.

- The best thickness for the bottom of the pans is 2 – 3 mm of enamelled steel and 4 – 6 mm for stainless steel with sandwich type bottoms.
- If these rules are not followed, then there will be a great loss of heat and energy. Heat not absorbed by the saucepan, will spread to the hob, frame and surrounding cabinets.
- Preferably cover pans with a lid to permit cooking at a lower heat.
- Always cook vegetables and potatoes, etc. in as little water to reduce cooking times.
- Food or liquid that has high sugar content may damage the hob top if it comes into contact with the ceramic hob surface. Any spillages should be wiped up immediately, however this may not prevent the hob surface from becoming damaged.
- **IMPORTANT:** The ceramic hob surface is tough; however it is not unbreakable and can be damaged. Especially if pointed or hard objects are allowed to fall on it with some force.
- **DO NOT USE THE HOB IF THE SURFACE BECOMES BROKEN OR CRACKED. YOU SHOULD CONTACT THE BAUMATIC SERVICE DEPARTMENT IMMEDIATELY.**



Cleaning operations must only be carried out when the hob is cool.

The appliance should be disconnected from your mains supply before commencing any cleaning process.

Cleaning the ceramic hob top



Any residues that are left on the hob top surface from cleaning agents **will** damage it. You should remove any residues with warm water mixed with a little washing up liquid.



Abrasive cleaners or sharp objects will damage the hob surface; you should clean it using warm water mixed with a little washing up liquid.



You may find it easier to clean some deposits whilst the hob surface is still warm. However you should take care not to burn yourself if cleaning the hob surface when it is still warm.

After each use

- Wipe the appliance over with a damp cloth.
- Dry the appliance by rubbing the surface with a clean cloth.

Cleaning table

Type of deposit	Remove immediately?	Remove when the appliance has cooled down?	What should I use to remove the deposit?
Sugar or food/liquid containing sugar	Yes	No	Ceramic hob scraper
Tin foil or plastic	Yes	No	Ceramic hob scraper
Fat splashes	No	Yes	Ceramic hob cleaner
Metallic discolouration	No	Yes	Ceramic hob cleaner
Water splashes or water rings	No	Yes	Ceramic hob cleaner

Using a ceramic hob scraper

Your appliance will be provided with a hob scraper. The following guidelines should also be followed when using the ceramic hob scraper: -

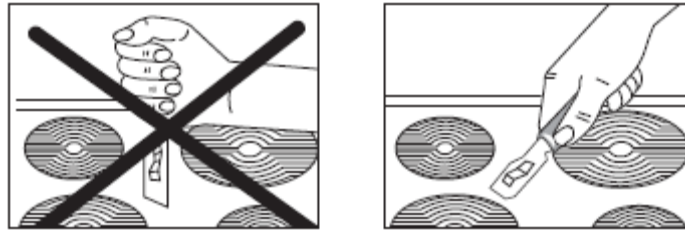

- The scraper should be placed on the ceramic surface at an angle.
- Residues should be removed by sliding the blade carefully over the ceramic surface.
- The ceramic surface should be wiped with a damp cloth that has been placed in warm water mixed with a small amount of washing up liquid.
- Dry the appliance by rubbing the surface with a clean cloth.

Using a specialist ceramic hob cleaner

It is possible to purchase a specialist ceramic hob cleaner/conditioner.

You should follow the instructions given by the manufacturer of the specialist ceramic hob cleaner. You should ensure that it is suitable for use on your appliance.

Installation



The installation must be carried out by a suitably qualified person, in accordance with the current version of the following.

- **UK Regulations and Safety Standards or their European Norm Replacements.**
- **Building Regulations** (issued by the Department of the Environment).
- **Building Standards** (issued by the Scottish Development Department).
- **IEE Wiring Regulations.**
- **Electricity At Work Regulations.**

Positioning



The adjacent furniture must be able to withstand a minimum temperature rise of 85°C above the ambient temperature of the room it is located in, during periods of use.

This appliance is classified as Class 3 and therefore is to be built into a kitchen unit (depending on size) or 600 mm worktop that is at least 30 mm thick. The following minimum clearance distances must be observed: -

- 700 mm between the hob surface and the underside of any horizontal surface above it.
- 50 mm clearance around the sides and front of the appliance.
- 55 mm clearance between the back of the hob surface and the wall behind it.
- If the hob is positioned so that the right or left hand side of the appliance will be near to the edge of a kitchen unit. There must be a gap of at least 150 mm between the side of the hob and the vertical surface of the kitchen unit.

Unpacking the appliance

When unpacking the appliance please check that the following items are contained within the packaging: -

- 1 Baumatic hob
- 1 Ceramic hob scraper
- 1 Installation and instruction manual
- 1 Baumatic guarantee card
- 4 Fixing brackets
- 4 Fixing screws
- 1 Sealing strip

Installing the appliance

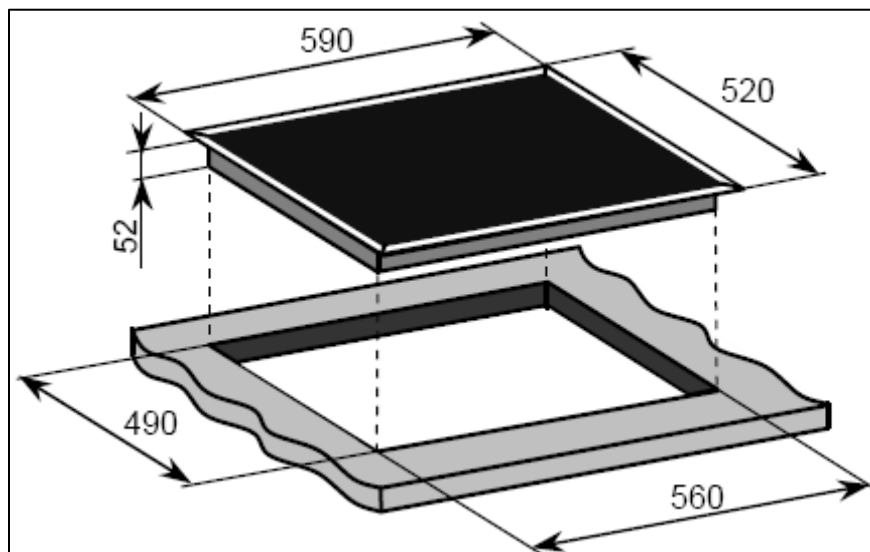

- Cut a hole in the worktop that corresponds with the drawing shown above.

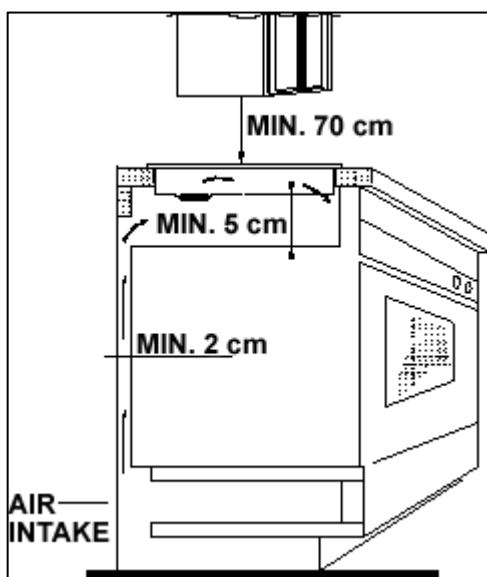

- **IMPORTANT:** You must observe the ventilation requirements shown in the drawing opposite.

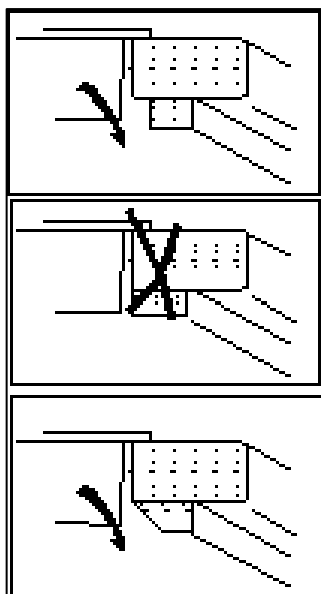

- **IMPORTANT:** There are ventilation holes around the outside of the hob. **YOU MUST** ensure that these holes are not blocked by the work top, when you put the hob into position (see drawing opposite).
- Carefully turn the hob upside down and place it on a cushioned mat.

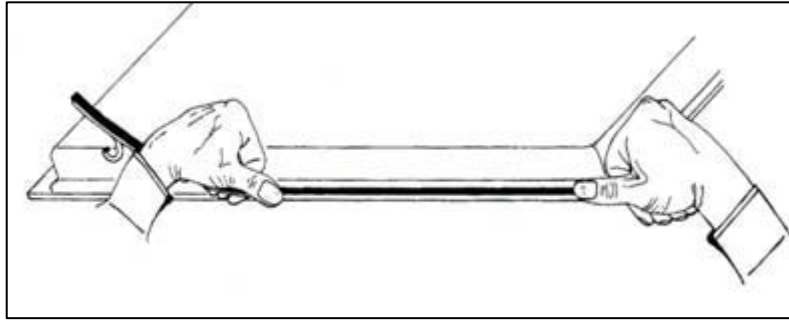

- Apply the sealing strip provided around the edge of the appliance.
- The protective covering must be removed from both sides.
- Do not leave a gap in the sealing agent or overlap the thickness.
- **IMPORTANT:** Do not use a silicon sealant to seal the appliance against the aperture. This will make it difficult to remove the hob from the aperture in future, particularly if it needs to be serviced.

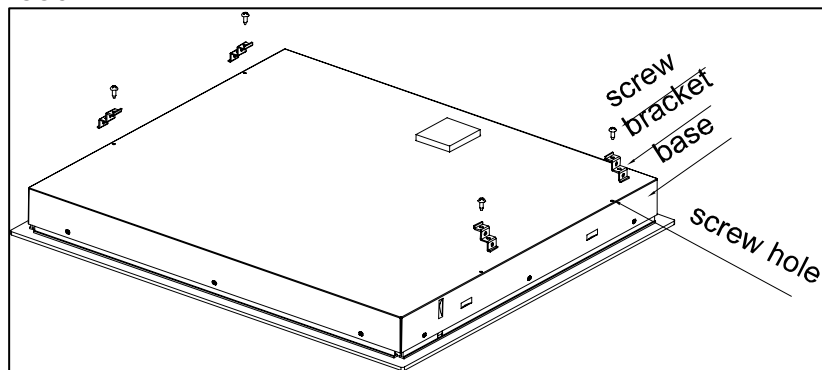

- Carefully turn the hob back over and then gently lower it into the aperture hole that you have cut out.
- There are holes on the base or the sides of the hob that you can fix the four brackets to. There are three holes in each one of the brackets.



- You should place the bracket on the underneath of the hob, in a position that is appropriate for the aperture that you have cut out. Using the screws provided, fix the bracket to the hob. These screws **MUST** be securely tightened.

Electrical connection



This appliance must be installed by a qualified person in accordance with the latest edition of the I.E.E. Regulations and in compliance with Baumatic's instructions.

Before connecting the appliance, make sure that the supply voltage marked on the rating plate corresponds with your mains supply voltage.

WARNING: THIS APPLIANCE MUST BE EARTHED.

- This appliance must be wired into a 30 A double pole switched fused spur outlet, having 3 mm contact separation and placed in an easily accessible position adjacent to the appliance. It should not be located above the appliance and no more than 1.25m away from it.
- The spur outlet must still be accessible even when your hob is located in its operating position.
- Cable type: H05 RRF 3 core x 4 mm²

Connecting the mains supply cable

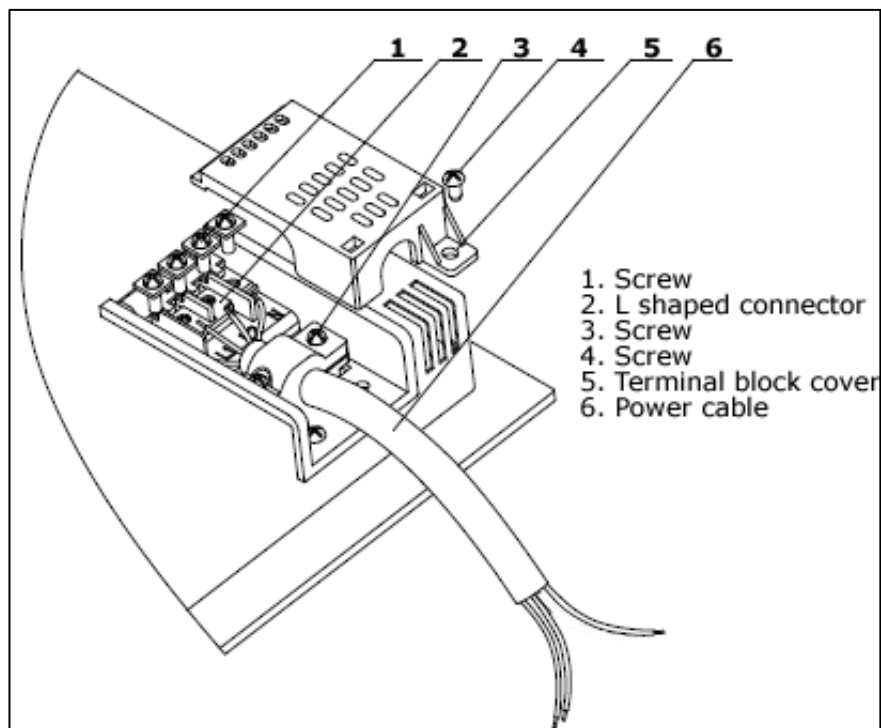

- The mains terminal block is located on the underside of the hob and the terminals are accessible by removing the terminal block cover by removing the cover screw.

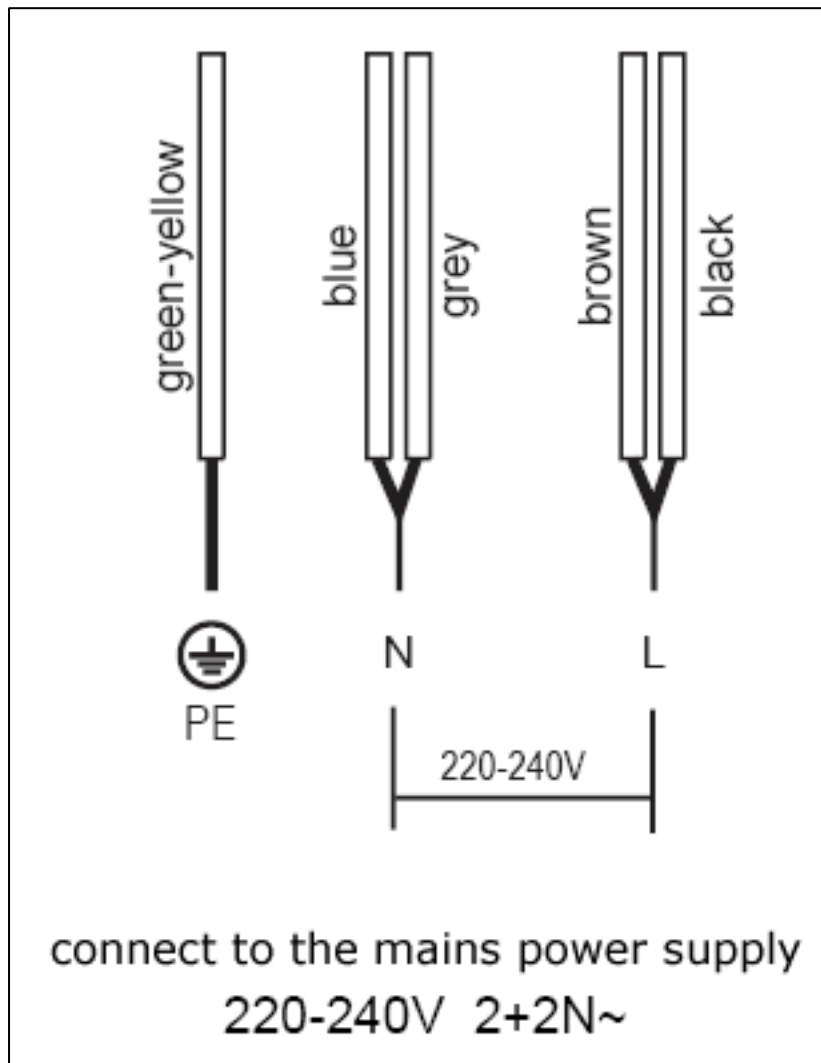

- The cable connections must be in accordance with the diagram located on the bottom of the hob (see above).
- You should use a good quality screwdriver to carefully, fully tighten ALL of the terminal screws.
- **If when the hob is first switched on, only two of the zones work, you should recheck that the terminal screws are all fully tightened. This should be done before contacting the Baumatic Service Department.**
- **IMPORTANT:** The appliance must NOT be connected to the mains supply by means of a 13A plug and socket.
- The cable can be looped if necessary, but make sure that is not kinked or trapped when the hob is in position. Care must be taken to avoid the cable being in contact with hot parts of the appliance.

Replacing the mains supply cable

If the mains supply cable is damaged, then it must be replaced by an appropriate replacement.

The mains supply cable should be replaced in accordance with the following instructions:

- **Switch the appliance off at the control switch.**
- Open the terminal block on the underside of the hob.
- Unscrew the terminal screws fixing the cable.
- Replace the cable with one of the same length and in accordance with the specification given on page 23.
- The “green-yellow” earth wire must be connected to the terminal marked \perp . It must be about 10 mm longer than the live and neutral wires.
- The “blue” neutral wire must be connected to the terminal marked with letter (N) - the live wire must be connected to the terminal marked with letter (L).

My appliance isn't working correctly

- **The cooking zones are not functioning or will not switch on.**
- * It has been more than 2 minutes since the appliance was switched on. You should switch the appliance back on again, using the ON/OFF button and then switch on a cooking zone.
- * The safety lock has been switched on (see the “Locking the hob top” section for information on how to turn off the safety lock).
- * Several cooking zone selection buttons have been pressed at once. You should only try to switch on one cooking zone at once.
- * The safety cut out has been triggered. Press the ON/OFF button to reset the hob.
- * Check that the mains electrical supply to the appliance is correct and working. Check the mains fuse.

- **The residual heat indicator has not come on after I have switched a cooking zone off.**
- * The cooking zone has only been turned on for a short period of time; therefore it did not go above 60°C.
- * **IMPORTANT:** If the cooking zone does appear to be hotter than 60°C and the residual heat indicator has not come on, you should call the Baumatic Service Department.
- **A humming sound is heard when a cooking zone is selected.**
- * This is normal; the sound will disappear when the zone heats up.
- **The cooking zones have become discoloured.**
- * This maybe caused by burnt on remnants of food. This will not affect the working of the appliance. However you should make sure that the cleaning instructions are being followed regularly.



IMPORTANT: If your appliance appears not to be operating correctly, then you should disconnect it from your mains supply and then contact the Baumatic Service Department on telephone number (0118) 933 6911.

DO NOT ATTEMPT TO REPAIR THE APPLIANCE YOURSELF.

Please note that if an engineer is asked to attend whilst the product is under guarantee and finds that the problem is not the result of an appliance fault, then you may be liable for the cost of the call out charge.

The appliance must be accessible for the engineer to perform any necessary repair. If your appliance is installed in such a way that an engineer is concerned that damage will be caused to the appliance or your kitchen, then he will not complete a repair.

This includes situations where appliances have been tiled in, sealed in with sealant, have wooden obstructions placed in front of the appliance, like plinths. Or any installation other than the one specified by Baumatic Ltd. has been completed.

Please refer to the conditions of guarantee that appear on the warranty card that you receive with the appliance.



You will be mine ...

United Kingdom

Baumatic Ltd.,
Baumatic Buildings,
6 Bennet Road,
Reading, Berkshire
RG2 0QX
United Kingdom

Sales Telephone

(0118) 933 6900

Sales Fax

(0118) 931 0035

Service Telephone

(0118) 933 6911

Service Fax

(0118) 986 9124

Spares Telephone

(01235) 437244

Baumatic Advice Line

(0118) 933 6933

E-mail:

sales@baumatic.co.uk
technical@baumatic.co.uk

Website:

www.baumatic.co.uk

Republic of Ireland

01- 6266 798

Czech Republic

Baumatic CR spol s.r.o.
Amperova 495
46215, Librec
Czech Republic

+420 800 185 263

www.baumatic.cz

Slovak Republic

Baumatic Slovakia, s.r.o.
Skultetyho 1
831 04 Bratislava 3
Slovakia

+421 255 640 618

Germany

Baumatic Gmbh
Janderstrasse 9
Mannheim, 68199
Germany

+4962 112 9190

www.baumatic.de

Italy

Baumatic Italia S.R.L.
Via Caltana 129
Campodarsego (Padova), 35011
Italy

+3904 9920 2297

www.baumatic.it

Holland

Baumatic Benelux B.V.
Grindzuigerstraat 22
1333 MS ALMERE
The Netherlands

+3136 549 1555

www.baumatic.nl

