

**PO900SS**  
**60 cm Built in multifunction**  
**self cleaning pyrolytic**  
**double oven.**

**Instruction manual**

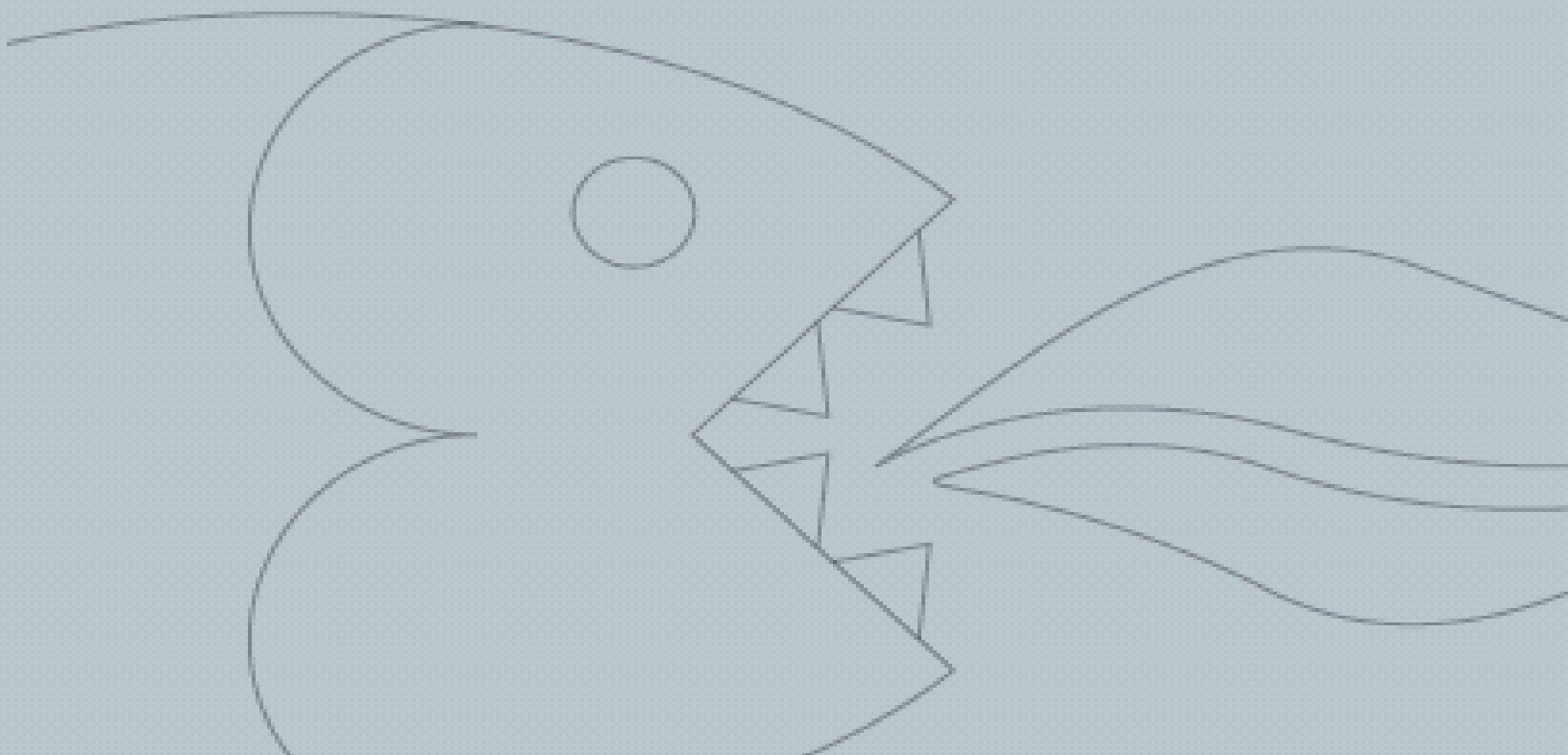

  
**Baumatic®**

# User Manual for your Baumatic

## PO900SS 60 cm Built in multifunction self cleaning pyrolytic double oven



***NOTE: This User Instruction Manual contains important information, including safety & installation points, which will enable you to get the most out of your appliance. Please keep it in a safe place so that it is easily available for future reference; for you or any person not familiar with the operation of the appliance.***

# Contents

<b>Environmental note</b>	4
<b>Important safety information</b>	5 – 7
<b>Specifications</b>	8 - 11
Product and aperture dimensions	8
Product specifications	9
Standard accessories	9
Optional extras	9
Electrical details	9
Control panel	10
Oven programmer/timer buttons	10
Oven programmer/timer display	11
<b>Setting and using the oven programmer/timer</b>	11 -17
Selecting manual operation mode	11
Setting the time of day	11
Before first use	12
Setting the minute minder function (main and bottom oven)	13
Setting the duration function (main oven only)	14
Selecting the end cook function (main oven only)	15
Setting the start and end time function (main oven only)	16
Adjusting the audible signal	17
<b>Selecting a cooking function and temperature</b>	17 - 21
Selecting manual operation mode	17
Selecting a main oven function	17 - 18
Main oven thermostat control knob	18
Selecting a lower oven function	19
Lower oven thermostat control knob	19
Oven operating lights (main and lower oven)	19
Cooking guidelines	20
Warnings	20 - 21
<b>Cleaning and maintenance</b>	21 – 25
Pyrolytic cleaning (main oven only)	21 – 22
General cleaning instructions	23
Replacing the oven bulb (main oven)	24
Replacing the oven bulb (lower oven)	24
Removing the oven door for cleaning	25
<b>Installation</b>	26 – 30
Electrical connection	26
Connecting the mains supply cable	27 - 28
Replacing the mains supply cable	28
Installing the oven into the kitchen cabinet	29
Positioning the appliance	29
Ventilation requirements	30
<b>My appliance isn't working correctly</b>	31 – 32
<b>Contact details</b>	33

**This appliance is marked according to the European directive 2002/96/EC on Waste electrical and Electronic Equipment (WEEE). By ensuring this product is disposed of correctly, you will help prevent potential negative consequences for the environment and human health, which could otherwise be caused by inappropriate waste handling of this product.**

The symbol  on the product, or on the documents accompanying the product, indicates that this appliance may not be treated as household waste. Instead it shall be handed over to the applicable collection point for the recycling of electrical and electronic equipment.

**Disposal must be carried out in accordance with local environmental regulations for waste disposal.**

**For more detailed information about treatment, recovery and recycling of this product, please contact your local city office, your household waste disposal service or the shop where you purchased the product.**



- The packaging materials that Baumatic uses are environmentally friendly and can be recycled.
- Please discard all packaging material with due regard for the environment.

## IMPORTANT SAFETY INFORMATION



Your safety is of the utmost importance to Baumatic. Please make sure that you read this instruction booklet **before** attempting to install or use the appliance. If you are unsure of any of the information contained in this booklet, please contact the Baumatic Advice Line.

### General Information

- This appliance is designed for domestic household use and can be built into a standard kitchen cabinet or housing unit.
- **IMPORTANT:** The adjacent furniture or housing and all materials used in the installation **must** be able to withstand a minimum temperature of 85°C above the ambient temperature of the room it is located in, whilst in use.
- Certain types of vinyl or laminate kitchen furniture are particularly prone to heat damage or discolouration at temperatures below the guidelines given above.
- Any damage caused by the appliance being installed in contravention of this temperature limit, or by placing adjacent cabinet materials closer than 4mm to the appliance, **will be the liability of the owner.**
- The use of this appliance for any other purpose or in any other environment without the express agreement of Baumatic Ltd. will invalidate any warranty or liability claim.
- Your new appliance is guaranteed against electrical or mechanical defects, subject to certain exclusions that are noted in Baumatic's Conditions Of Guarantee. The foregoing does not affect your statutory rights.
- **Repairs may only be carried out by Baumatic service engineers or their authorised service agent.**

### Warning and safety instructions

- This appliance complies with all current European safety legislation. Baumatic do wish to emphasise that this compliance does not remove the fact that the appliance surfaces **will become hot during use and retain heat after operation.**

## Child Safety

- Baumatic strongly recommend that babies and young children are prevented from being near to the appliance and not allowed to touch the appliance **at any time**.
- If it is necessary for younger family members to be in the kitchen, please ensure that they are kept under close supervision at all times.

## General Safety

- **Do not** place heavy objects on the oven door or lean on the oven door when it is open, as this can cause damage to the oven door hinges.
- **Do not** leave heated oil or fat unattended, as this is a fire risk.
- **Do not** place pans or baking trays directly on the base of the oven cavity, or line it with aluminium foil.
- **Do not** allow electrical fittings or cables to come into contact with areas on the appliance that get hot.
- **Do not** use the appliance to heat the room it is located in or to dry clothing.
- **Do not** install the appliance next to curtains or soft furnishings.
- **Do not** attempt to lift or move cooking appliances by using the oven door or handle, as this may cause damage to the appliance or result in injury to the person lifting the appliance.

## Cleaning

- Cleaning of the oven should be carried out on a regular basis.
- Great care should be taken whilst using this appliance and when following the cleaning procedure.
- **IMPORTANT:** The appliance must be disconnected from the mains before following the cleaning procedure.

## Installation



**This appliance must be correctly installed by a suitably qualified person, strictly in accordance with the manufacturer's instructions.**

- **Baumatic Ltd. declines any responsibility for injury or damage, to person or property, as a result of improper use or installation of this appliance.**
- Heat, steam and moisture will be created during use of the appliance, take care to avoid injury and ensure that the room is adequately ventilated. If the appliance is going to be used for prolonged periods of time, then additional ventilation may be required.
- Please consult with your qualified installer if you are in any doubt about the amount of ventilation that you will require.

### **Declaration of conformity**

- In the parts destined to come into contact with foodstuffs, this appliance is in accordance with the requirements of the EC directive 89/109 transposed in the Italian Legislative Decree No. 108 of 25/01/92.
- **CE:** Appliance conforming to the European directives 89/336/EEC, 93/68/EEC, 73/23/EEC and subsequent revisions and "RoHS" directive 2002/95/CE.\*
- The manufacturer declares that the oven is built using certified materials and requires the appliance to be installed in accordance with the standards currently in force. This appliance must be used by a trained person for domestic purposes only.

- \* The RoHS directive stands for "the restriction of the use of certain hazardous substances in electrical and electronic equipment". This directive bans the placing on the EU market of new electrical and electronic equipment containing more than the agreed levels of lead, cadmium, mercury, hexavalent chromium, polybrominated biphenyl (PBB) and polybrominated diphenyl ether (PBDE) flame retardants.

## Specifications

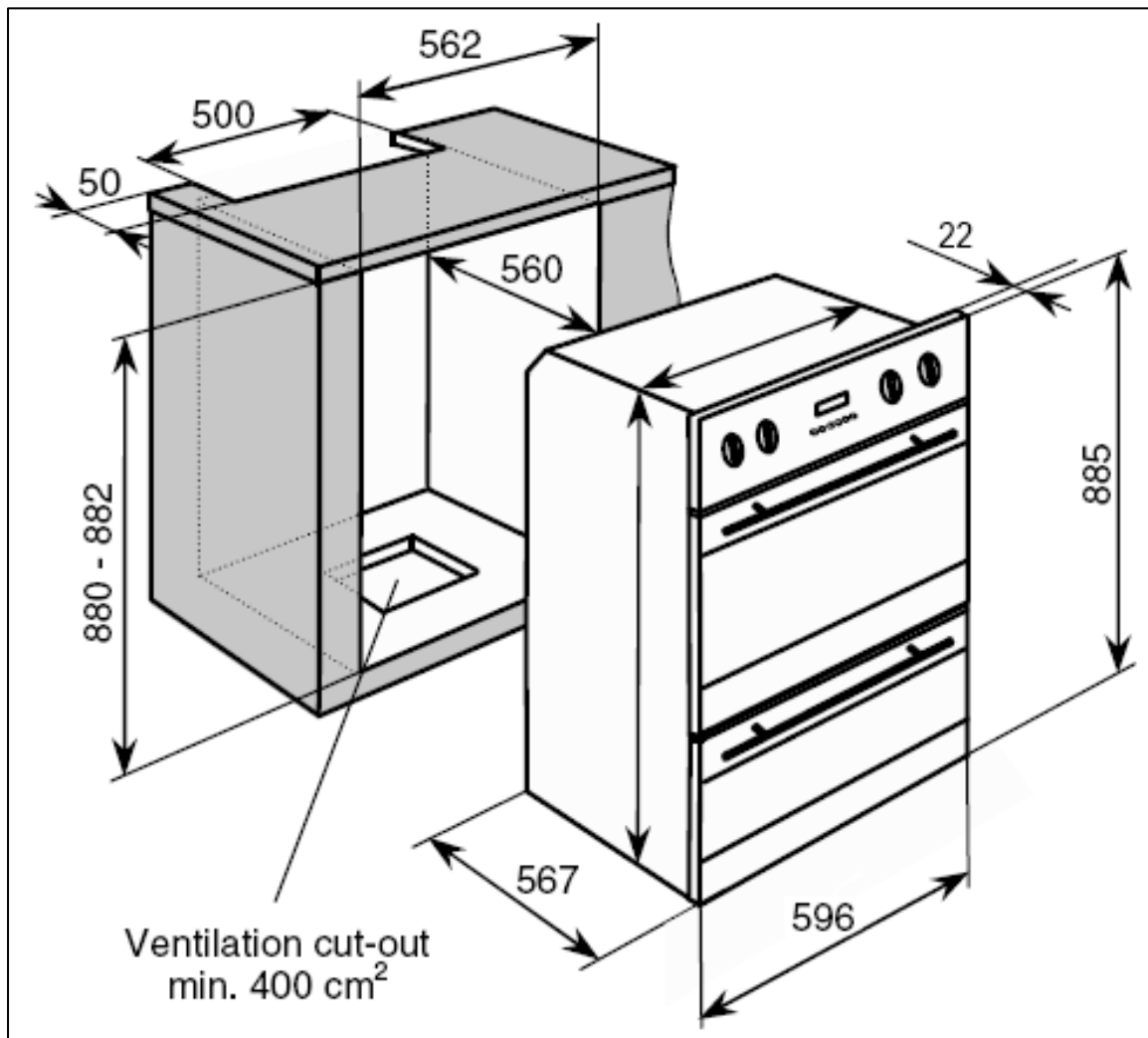

### Product Dimensions

Height: 885 mm  
Width: 596 mm  
Depth: 567 mm

### Aperture dimensions

880 mm – 882 mm  
562 mm  
560 mm (min)

### Cooling fans

- Two tangential cooling fans are fitted inside of this appliance, to make the internal temperature of the oven stable and the external surface temperature lower.



## Product specifications:

- Energy efficiency class: A
- LED full programmer
- 2 Cooling fans
- Thermostatically controlled grills
- Electronically controlled thermostat (main oven only)
- Triple-glazed removable doors
  
- **Main oven: multifunction self-cleaning pyrolytic oven**
- 9 functions
- Capacity: 59 litres
- Triple-glazed removable door
- Automatic safety door-lock when in pyrolytic mode
- Catalytic exhaust
  
- **Lower oven: static oven and grill**
- 4 functions
- Capacity: 37 litres

## Standard accessories:

- Removable side racks (lower oven only)
- 2 x Safety shelves
- 2 x Enamelled baking trays with handle
- 2 x Trivets

## Optional extra:

- BPS2 Pizza stone

## Electrical details:

Rated Voltage:	230 Vac 50 Hz
Supply Connection:	30 A (double pole switched fused outlet with 3mm contact gap)
Max Rated Inputs:	5.05 kW
Mains Supply Lead:	3 x 2.5 mm <sup>2</sup>

## Oven Light Bulb:

**Main oven:** 25 W 500°C screw type pigmy

**Bottom oven:** 25 W 300°C screw type pigmy

For future reference please record the following information which can be found on the rating plate and the date of purchase which can be found on your sales invoice. The rating plate for your oven can be located by opening the bottom oven door and looking on the front frame of the oven chassis.

**Model Number** .....

**Serial Number** .....

**Date of Purchase** .....

**Control Panel**

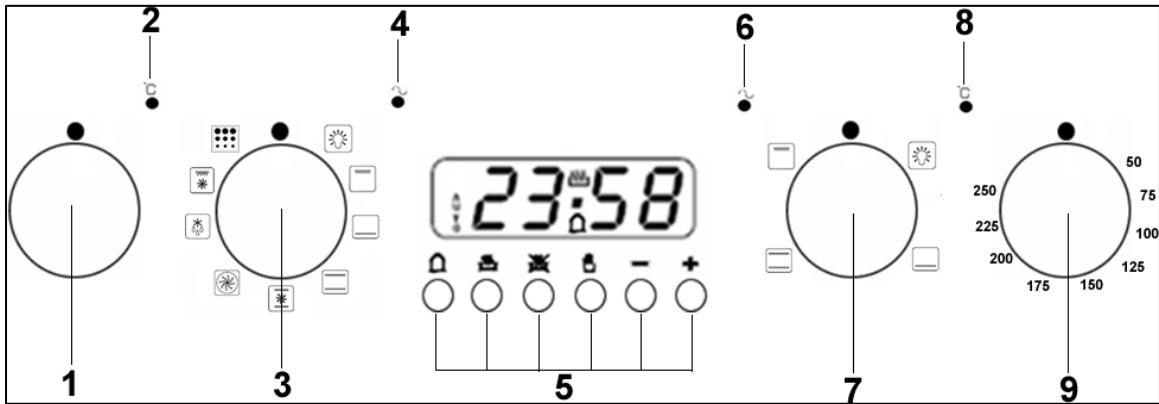

- 1) Main oven thermostat knob
- 2) Main oven operating light
- 3) Main oven function selection knob
- 4) Main oven power indicator light
- 5) Oven programmer/timer buttons
- 6) Lower oven power indicator light
- 7) Lower oven function selection knob
- 8) Lower oven operating light
- 9) Lower oven thermostat knob

**Oven programmer/timer buttons**

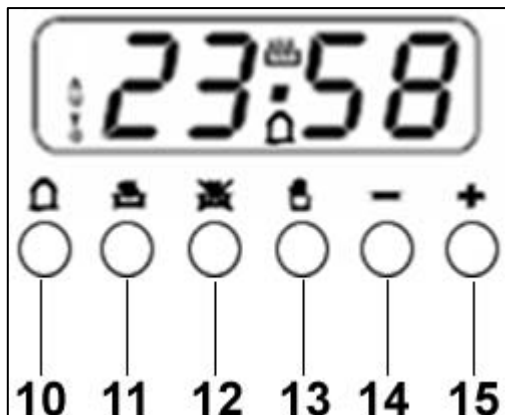

- 10) Minute minder button
- 11) Duration button
- 12) End cook button
- 13) Manual operation button
- 14) Minus button
- 15) Plus button

## Oven programmer/timer display

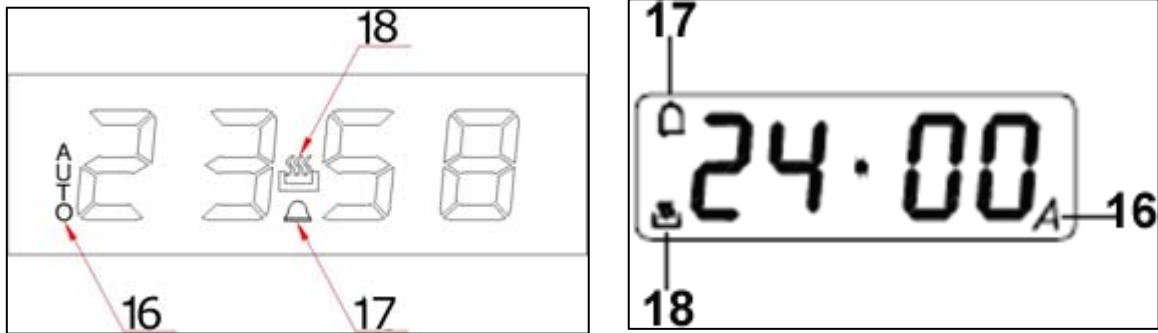

- 16) Auto function symbol
- 17) Minute minder symbol
- 18) Manual operation symbol.

## Setting and using the oven programmer/timer

### Selecting manual operation mode

After your appliance is connected to your mains supply for the first time, the numbers on the timer display will flash. Before you can select a cooking function or set a temperature, you must set the appliance into manual operation mode.

- To select manual operation mode, press the manual operation button (13) on the oven programmer/timer.

### Setting the time of day

*After setting your oven for manual operation, you should also set the time of day.*

- Use the minus button (14) and plus button (15) to adjust the time that appears in the display. After getting the display to the correct time, release the minus and plus buttons. After five seconds the time will fix in the display and you will be able to use your oven.
- The manual operation symbol (18) will light on the oven programmer/timer display.

## Before first use

- To remove any residue from the oven cavities that may have been left from the manufacturing process, you should select the fan oven function for the main oven and the conventional oven function for the secondary oven. Separately set each oven to its maximum temperature setting.
- It is perfectly normal for a smell to be produced during this process.
- You should make sure that any windows in the room are left open during this process.
- It is advisable for you not to remain in the room whilst the burning off process is taking place.
- You should leave each oven on maximum setting for 30 – 40 minutes.
- **IMPORTANT: You should not burn off both ovens simultaneously.**
- After the oven cavities have cooled, they should then be cleaned with warm soapy water, using either a sponge or soft cloth. No abrasive cleaners should be used.
- Outer parts of the oven should be cleaned with warm soapy water, using either a sponge or soft cloth. No abrasive cleaners should be used.
- We would recommend that an appropriate stainless steel cleaner and polish is regularly used on the stainless steel surfaces of this appliance.

## Setting the minute minder function (main and bottom oven)

*You are able to set the minute minder at any time, regardless of whether an oven function has been selected. You can set a countdown period using the minute minder function and an alarm will sound when this period of time has elapsed.*

- Press the minute minder button **(10)**, the display will show a value of 00:00. Set the period of time that you wish the minute minder to countdown for, by using the minus **(14)** and plus **(15)** buttons.
- Once the display has got to your desired countdown time, let go of the minus and plus buttons. The minute minder symbol **(17)** will appear on the timer display.
- Once a countdown time has been set, it is possible to shorten or lengthen the time by using the minus or plus buttons.
- An alarm will sound when the countdown time has elapsed. The alarm can be silenced by pressing the minute minder button **(10)** or manual operation button **(13)**.
- **Important:** The oven will continue to heat once the alarm has been silenced. If you have finished cooking, then you should turn the relevant oven function selector and thermostat control knob to the off position.

## Setting the duration function (main oven only)

*This function will allow you to set a countdown time similar to the minute minder function. However the oven will no longer continue to heat, once the countdown period has elapsed.*

- Use the main oven thermostat control knob **(1)** to set the temperature that you require. The manual operation symbol **(18)** will appear on the display.
- Use the main oven function selection knob **(3)** to select the mode of cooking that you require.
- It is then possible to set the duration of the cooking time that you require.
- Press the duration button **(11)** and the display will show a value of 00:00. Set the period of time that you wish the duration function to countdown for, by using the minus **(14)** and plus **(15)** buttons.
- Once the display has got to your desired countdown time, let go of the minus and plus buttons. The countdown will start immediately and the word AUTO (or A symbol) **(16)** will appear on the timer display.
- Once a countdown time has been set, it is possible to shorten or lengthen the time by using the minus or plus buttons.
- An alarm will sound when the countdown time has elapsed and the oven will switch off. The word AUTO (or A symbol) will flash and the manual operation symbol will disappear.
- To silence the audible signal and return the oven to manual operation mode, you should press the manual operation button. The word AUTO (or A symbol) will disappear from the display and the manual operation symbol will appear instead.
- **Important:** If you do not turn the thermostat control knob and main oven function selection knob to the off position. then the appliance will continue to operate as soon as you press the manual operation button.

## Setting the end cook function (main oven only)

*This function is similar to the duration function, however instead of selecting a period of time that you wish the oven to switch off after. You select the time of day that you wish the oven to switch off at.*

- Use the main oven thermostat control knob **(1)** to set the temperature that you require. The manual operation symbol **(18)** will appear on the display.
- Use the main oven function selection knob **(3)** to select the mode of cooking that you require.
- Press the end cook button **(12)** and the display will show a value of 00:00. Set the time of day that you wish the oven to stop cooking at by using the minus **(14)** and plus **(15)** buttons. The timer will calculate how long the cooking time will be, based on the time of day that you have selected and show it on the display.
- Once the display has got to the time of day that you want the oven to stop cooking at, let go of the minus and plus buttons. The countdown will start immediately and the word AUTO (or A symbol) **(16)** will appear on the timer display.
- When the time is set, it can be modified by pressing the minus and plus buttons.
- When the time of day reaches the end of the cooking time that you have set, the oven will switch off and an alarm will sound. The word AUTO (or A symbol) will flash and the manual operation symbol will disappear.
- To silence the audible signal and return the oven to manual operation mode, you should press the manual operation button. The word AUTO (or A symbol) will disappear from the display and the manual operation symbol will appear instead.
- **Important:** If you do not turn the thermostat control knob and oven function selection knob to the off position, then the appliance will continue to operate as soon as you press the manual operation button.

## Setting the start and end time function (main oven only)

***This function will allow you to set a time in the future that the oven switches on at and a time that the oven will switch off at.***

- Use the main oven thermostat control knob **(1)** to set the temperature that you require. The manual operation symbol **(18)** will appear on the display.
- Use the main oven function selection knob **(3)** to select the mode of cooking that you require.
- Press the duration button **(11)** and the display will show a value of 00:00. Set the period of time that you wish to cook for, by using the minus **(14)** and plus **(15)** buttons. The word AUTO (or A symbol) **(16)** will appear on the timer display.
- **Immediately** press the end cook button **(12)** and the timer display will show the value 00:00. Set the time of day that you want the oven to switch off at, using the minus and plus buttons.
- The oven will calculate what time it needs to switch on at, so that your food will cook for the length of time that you selected. It will automatically switch itself on, once it reaches the time of day that it has calculated.
- When the time of day reaches the end of cooking time that you set, the oven will switch off and an alarm will sound. The word AUTO (or A symbol) will flash and the manual operation symbol will disappear.
- To silence the audible signal and return the oven to manual operation mode, you should press the manual operation button. The word AUTO (or A symbol) will disappear from the display and the manual operation symbol will appear instead.
- **Important:** If you do not turn the thermostat control knob and oven function selection knob to the off position, then the appliance will continue to operate as soon as you press the manual operation button.



## Adjusting the audible signal

There are 3 levels of audible signal available; to adjust it you should do the following:

- When the time of day is shown on the timer display, press the minus button for approximately 2 seconds. You will then hear the current level of audible signal.
- Repeat this process until the audible signal reaches the level that you require, and then release the minus button.

## Selecting a cooking function and temperature

### Selecting manual operation mode

**After your appliance is connected to your mains supply for the first time, the numbers on the timer display will flash. Before you can select a cooking function or set a temperature, you must set the appliance into manual operation mode.**

- To select manual operation mode, press the manual operation button on the oven programmer.

### Selecting a main oven function

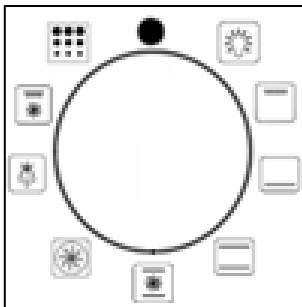

The main oven function selection knob should be used to select the particular mode of cooking that you require. The appliance will utilise different elements within the oven cavity, depending on the oven function that you select. When a function is selected, the main oven power indicator light will come on.



**OVEN LIGHT:** Separate light control which allows the light to be switched on, even when the oven not cooking.



**FULL GRILL:** This method of cooking utilises the inner and outer parts of the top element, which directs heat downwards onto the food. This function is suitable for grilling medium or large portions of sausages, bacon, steaks, fish etc.



**LOWER ELEMENT:** This method of cooking uses the lower element to direct heat upward to the food. For slow-cooking recipes or for warming up meals.



**CONVENTIONAL OVEN (top and lower element):** This method of cooking provides traditional cooking, with heat from the top and lower elements. This function is suitable for roasting and baking on one shelf only.



**CONVECTION OVEN AND FAN:** This method of cooking provides traditional cooking with heat from the top and the lower element, it also utilises the circulation fan. This ensures a fast and even distribution of the heat. Suitable for light and delicate baking, such as pastries.



**FAN OVEN:** This method of cooking uses the circular element while the heat is distributed by the fan. This results in a faster and more economical cooking process. The fan oven allows food to be cooked simultaneously on different shelves, preventing the transmission of smells and tastes from one dish onto another.



**DEFROST MODE:** The fan runs without heat to reduce the defrosting time of frozen foods. The time required to defrost the food will depend on the room temperature, the quantity and type of food. Always check food packaging for the defrosting instructions.



**FAN AND GRILL:** This method of cooking utilises the top element in conjunction with the fan, which helps to provide a quick circulation of heat. This function is suitable where quick browning is required and “sealing” the juices in, such as steaks, hamburgers, some vegetables etc.



**PYROLYTIC CLEANING:** This function cleans the oven cavity by raising the main oven temperature to approximately 500°C. The resultant ash deposits can be wiped away with a soft, damp cloth once the oven has cooled down.

### Main oven thermostat control knob

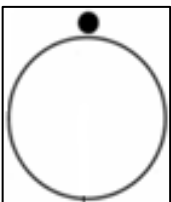

The oven thermostat control knob sets the required temperature of the oven. It is possible to regulate the temperature within a range of 50 - 250°C. The temperature that you have set will appear on the oven programmer/timer display. The control knob should be turned clockwise.

## Selecting a lower oven function

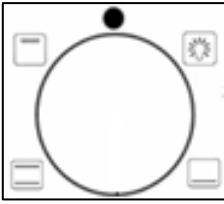

The lower oven function selection knob should be used to select the particular mode of cooking that you require. The appliance will utilise different elements within the oven cavity, depending on the oven function that you select. When a function is selected, the lower oven power indicator light will come on.



**OVEN LIGHT:** Separate light control which allows the light to be switched on, even when the oven not cooking.



**LOWER ELEMENT:** This method of cooking uses the lower element to direct heat upward to the food. For slow-cooking recipes or for warming up meals.



**CONVENTIONAL OVEN (top and lower element):** This method of cooking provides traditional cooking, with heat from the top and lower elements. This function is suitable for roasting and baking on one shelf only.



**FULL GRILL:** This method of cooking utilises the inner and outer parts of the top element, which directs heat downwards onto the food. This function is suitable for grilling medium or large portions of sausages, bacon, steaks, fish etc.

## Lower oven thermostat control knob

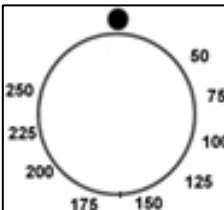

The oven thermostat control knob sets the required temperature of the oven. It is possible to regulate the temperature within a range of 50 - 250°C.

**Turn the control knob clockwise.**

## Oven operating lights (main and secondary oven)

These lights will come on to indicate that the oven's heating elements are in operation. The lights will switch off when the temperature set on the thermostat control knob has been reached. They will cycle on and off throughout the cooking time.

**You should not place food inside the cavity, until the correct cooking temperature has been reached.**

## Cooking guidelines

- Please refer to the information given on food packaging for guidance on cooking temperatures and times. Once familiar with the performance of your appliance, temperatures and times can be varied to suit personal preference.
- If you are using the fan oven function, then you should follow the information given on the food packaging for this particular mode of cooking.
- You should pre-heat the oven and not place food inside of it until the oven operating light has gone off. You can choose not to pre-heat when using the fan oven mode; however you should extend the cooking time given on the food packaging by at least ten minutes.
- **IMPORTANT:** You should pre-heat the oven if you are baking, regardless of whether you are using the main or secondary oven.
- If there is no guidance given on the food packaging specifically for cooking in fan oven mode, you can generally reduce the cooking time and temperature by 10% from the information given for conventional oven cooking.
- Make sure that frozen foods are thoroughly thawed before cooking, unless the instructions on the food packaging advise that you can “cook from frozen”.
- Before cooking, check that any accessories that are not required are removed from the oven.
- Place cooking trays in the centre of the oven and leave gaps between the trays to allow air to circulate.
- Try to open the door as little as possible to view the dishes.
- The oven light will remain on during cooking.

## Warnings

- Keep the oven door closed when using **any** of the cooking functions, **including** the grill functions.
- Do not use aluminium foil to cover the enamelled baking tray or heat items wrapped in aluminium foil under the grill. The high reflectivity of the foil could potentially damage the grill element.

- You should also never line the base of your oven with aluminium foil.
- During cooking, never place pans or cookware directly onto the bottom of your oven. They should always be placed on the shelves provided.
- The grill heating element and other internal components of the oven become extremely hot during operation, avoid touching them inadvertently when handling the food which you are grilling.
- **Important:** Be careful when opening the door, to avoid contact with hot parts of the oven and steam.
- **Warning:** Accessible parts may become hot during use. Young children should be kept well away from the oven when it is in use.
- The enamelled baking tray handle should only be used to reposition the tray and **NOT** for removing it from the oven cavity. When removing the enamelled baking tray, you should **ALWAYS** use an oven glove.
- The enamelled baking tray handle should not be left in position when the appliance is switched on.

## Cleaning and maintenance



### Pyrolytic cleaning (main oven only)

- **IMPORTANT: All accessories must be removed from inside the oven before commencing the pyrolytic cleaning function.**
- **The oven should not be left unattended when the pyrolytic cleaning cycle is in progress.**
- **All major food residues must be removed from the oven before starting this function.**
- Select the pyrolytic cleaning function by turning the main oven function selector knob to the cleaning symbol 
- After turning the selector knob to this function, a cleaning period of 90 minutes is automatically set. This should be sufficient if the pyrolytic cleaning cycle is completed on a weekly basis.

- The length of cleaning cycle can be increased by pressing the manual operation button and then pressing the timer plus button. This may be necessary if the oven is heavily soiled.
- On this oven function it is possible to increase the oven temperature to 475°C; you should do this by turning the thermostat control knob to its maximum setting.
- The oven door will automatically lock when the temperature inside the oven reaches 300°C. When this happens, the oven will give off an acoustic signal and a light on the control panel will light to indicate that the door is locked.
- During pyrolytic cleaning, the oven light will remain on.
- After the set time period has elapsed, the oven door will remain locked until the oven temperature has fallen below 300°C.
- When the oven has reached a warm temperature, you should use a soft damp cloth to wipe out the resultant ash deposits. For best cleaning results, you should not allow the oven to get completely cold before wiping away the ash deposits.
- When the pyrolytic cleaning cycle has completed, the oven will switch off and an alarm will sound. The word AUTO (or A symbol) will flash and the heating symbol will disappear.
- **DO NOT** attempt to open the oven door, until the door lock light has gone out.
- To silence the audible signal and return the oven to manual operation mode, you should press the manual operation button. The word AUTO (or A symbol) will disappear from the display and the manual operation symbol will appear instead.
- **Important:** If you do not turn the thermostat control knob and oven function selection knob to the off position, then the appliance will continue to operate as soon as you press the manual operation button.

## General cleaning instructions



**Cleaning operations must only be carried out when the oven is cool.**

**The appliance should be disconnected from your mains supply before commencing any cleaning process.**

- The oven should be thoroughly cleaned before it is operated for the first time and after each use. This will avoid residual food stuffs becoming baked on the oven cavity. After residues have been baked on several times, they are far more difficult to remove.
- **Never** clean the oven surfaces by steam cleaning.
- The lower oven cavity should only be cleaned with a damp cloth after each use of the oven. No abrasive cleaners should be used.
- The lower oven cavity should be cleaned regularly using warm, soapy water. No abrasive cleaners should be used.
- Any stains that may appear on the bottom of the oven will have originated from food splashes or spilt food, these splashes occur during the cooking process. These could possibly be a result of the food being cooked at an excessively high temperature or being placed in cookware that is too small.
- You should make sure that the cooking temperature that is selected is appropriate for the food that you are cooking. You should also ensure that the food is placed in an adequately sized dish and use the enamelled baking tray where appropriate.
- Outer parts of the oven should only be cleaned with warm soapy water, using either a sponge or soft cloth. No abrasive cleaners should be used.
- We would recommend that an appropriate stainless steel cleaner and polish is regularly used on the stainless steel surfaces of this appliance.
- If you use any form of oven cleaner on your appliance, then you must check with the manufacturer of the cleaner that it is suitable for use on your appliance.
- **Any damage that is caused to the appliance by a cleaning product will not be fixed by Baumatic free of charge, even if the appliance is within the guarantee period.**

## Replacing the oven bulb (main oven)



**IMPORTANT:** The oven must be disconnected from your mains supply before you attempt to either remove or replace the oven bulb.

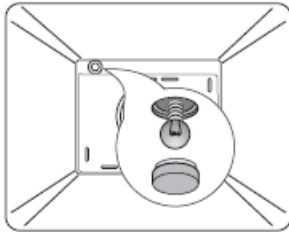

- Remove all oven shelves and the enamelled baking tray.
- Unscrew the lamp cover.
- Unscrew the bulb and remove it from its holder.
- Replace the bulb with a 25 W/500°C, screw type pigmy.
- **Do not** use any other type of bulb.
- Screw the lamp cover back into its original position.

## Replacing the oven bulb (lower oven)



**IMPORTANT:** The oven must be disconnected from your mains supply before you attempt to either remove or replace the oven bulb.

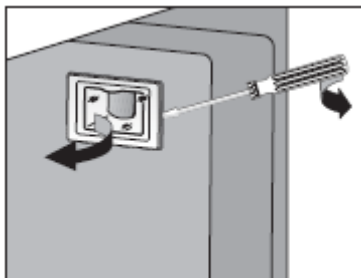

- Remove all oven shelves, the enamelled baking tray and the side rack that is on the same side as the oven light.
- Using a screwdriver, remove the lamp cover.
- Unscrew the bulb clockwise and remove it from its holder.
- Replace the bulb with a 25 W/300°C, screw type pigmy.
- **Do not** use any other type of bulb.
- Place the lamp cover back into position. There is a curve on one side of the cover; this should be on the right hand side as the cover goes back into place.



## Removing the oven door for cleaning

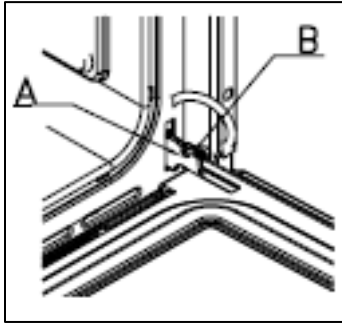

To facilitate the cleaning of the inside of the oven and the outer frame of the oven, the door can be removed as follows: -

- The hinges **(A)** have two movable bolts on them **(B)**.
- If you raise both of the movable bolts **(B)**, then the hinges **(A)** are released from the oven housing.
- You should grip the sides of the door at the centre and then incline it slightly towards the oven cavity and then by pulling it gently away from the oven cavity.
- **IMPORTANT:** You should make sure that the door is supported at all times and that you place the door on some padded material whilst cleaning it.
- The oven door and door glass should only be cleaned using a damp cloth and a small amount of detergent. The cloth **MUST NOT** have come into contact with any form of cleaning product or chemical previously.
- To refit the door you should slide the hinges back into their slots and open the door fully.
- **IMPORTANT:** The movable bolts **(B)** must be closed back into their original positions before closing the door.



- **Take care not to dislodge the hinge locking system when removing the door, as the hinge mechanism has a strong spring.**
- **Do not immerse the door in water at any time.**

## INSTALLATION



The installation must be carried out by a suitably qualified person, in accordance with the current version of the following.

- UK Regulations and Safety Standards or their European Norm Replacements.
- **Building Regulations** (issued by the Department of the Environment).
- **Building Standards** (issued by the Scottish Development Department).
- **IEE Wiring Regulations.**
- **Electricity At Work Regulations.**

Before connecting the appliance, make sure that the supply voltage marked on the rating plate corresponds with your mains supply voltage.

### **WARNING: THIS APPLIANCE MUST BE EARTHED.**

- This appliance should be wired into a 30 A double pole switched fused spur outlet, having 3 mm contact separation and placed in an easily accessible position adjacent to the appliance. The spur outlet must still be accessible even when your oven is located in its housing.

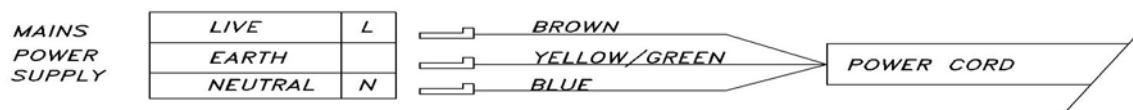

- To connect the oven power cord, loosen and remove the cover on the terminal block, in order to gain access to the contacts inside. Make the connection, securing the cord in place with the cable clamp provided and then immediately close the terminal block cover again.
- If you have to change the oven power cord, the earthing (yellow/green) conductor must always be 10 mm longer than the line conductors.
- Care must be taken to ensure that the temperature of the mains supply cable does not exceed 50°C.
- If the mains supply cable is damaged, then it must be replaced by an appropriate replacement.
- Cable type: H05 RRF 3 core x 2.5 mm<sup>2</sup>

## Connecting the mains supply cable

- The mains terminal block is located on the rear of the oven and the terminals are accessible by removing the terminal block cover. You should remove the cover screw to access this.
- The cable connections must be made in accordance with the diagram below: -

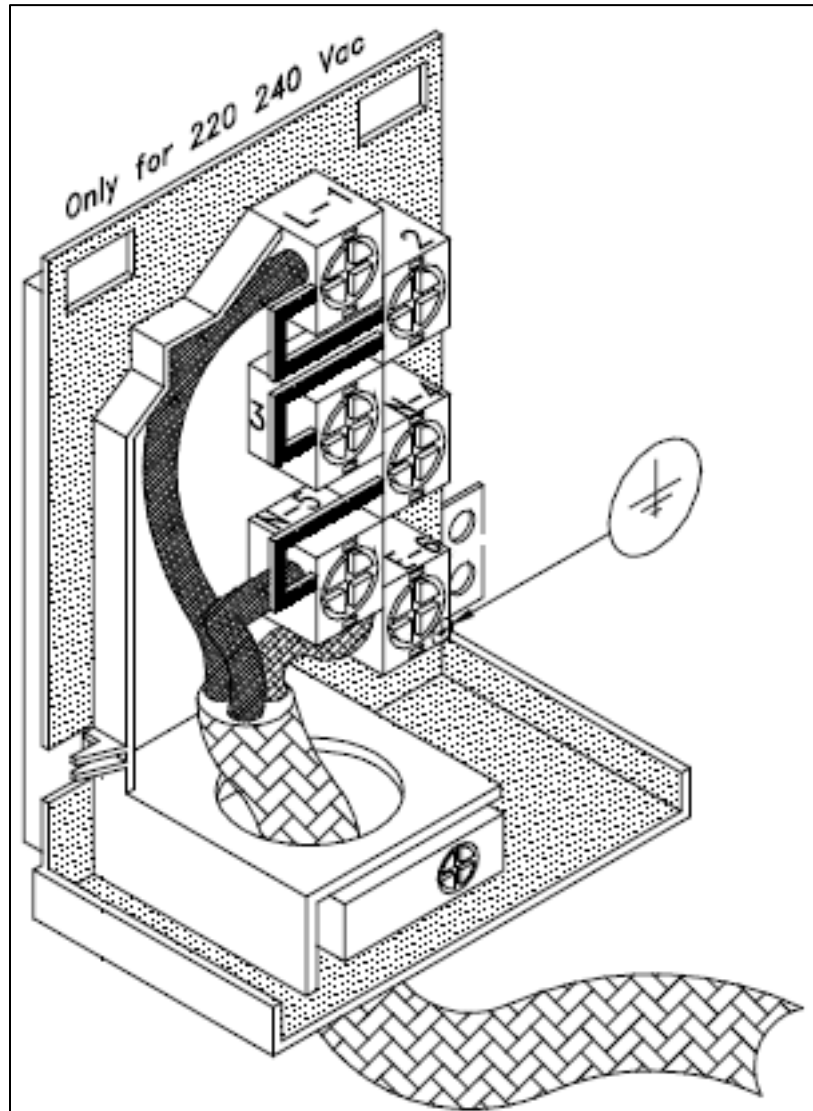

- 1, 2 and 3 are the live connection, 4 and 5 are the neutral connection and the remaining one is the earth connection.
- The live wire **MUST** be placed in connection number 1.  
The neutral wire **MUST** be placed in connection number 4.  
The earth wire **MUST** be placed in the connection marked with the  symbol.
- The brass links must be positioned as marked in the diagram above and once established **ALL** terminal screws must be tightened down firmly.

- **If when the oven is first switched on, it does not function correctly, you should recheck that the terminal screws are all fully tightened between the links. This should be done before contacting the Customer Care Department.**
- **IMPORTANT:** The appliance must NOT be connected to the mains supply by means of a 13A plug and socket.
- The cable can be looped if necessary, but make sure that is not kinked or trapped when the oven is in position. Care must be taken to avoid the cable being in contact with hot parts of the appliance.

### **Replacing the mains supply cable**

If the mains supply cable is damaged, then it must be replaced with a suitable replacement.

The mains supply cable should be replaced in accordance with the following instructions:

- **Switch the appliance off at the socket.**
- Open the terminal block on the back of the oven.
- Unscrew the terminal screws fixing the cable.
- Replace the cable with one of the same length and in accordance with the specification given on page 26.
- The "green-yellow" earth wire must be connected to the terminal marked  $\perp$ . It must be about 10 mm longer than the live and neutral wires.
- The "blue" neutral wire must be connected to the terminal marked with letter (N) - the live wire must be connected to the terminal marked with letter (L).

### Positioning the appliance

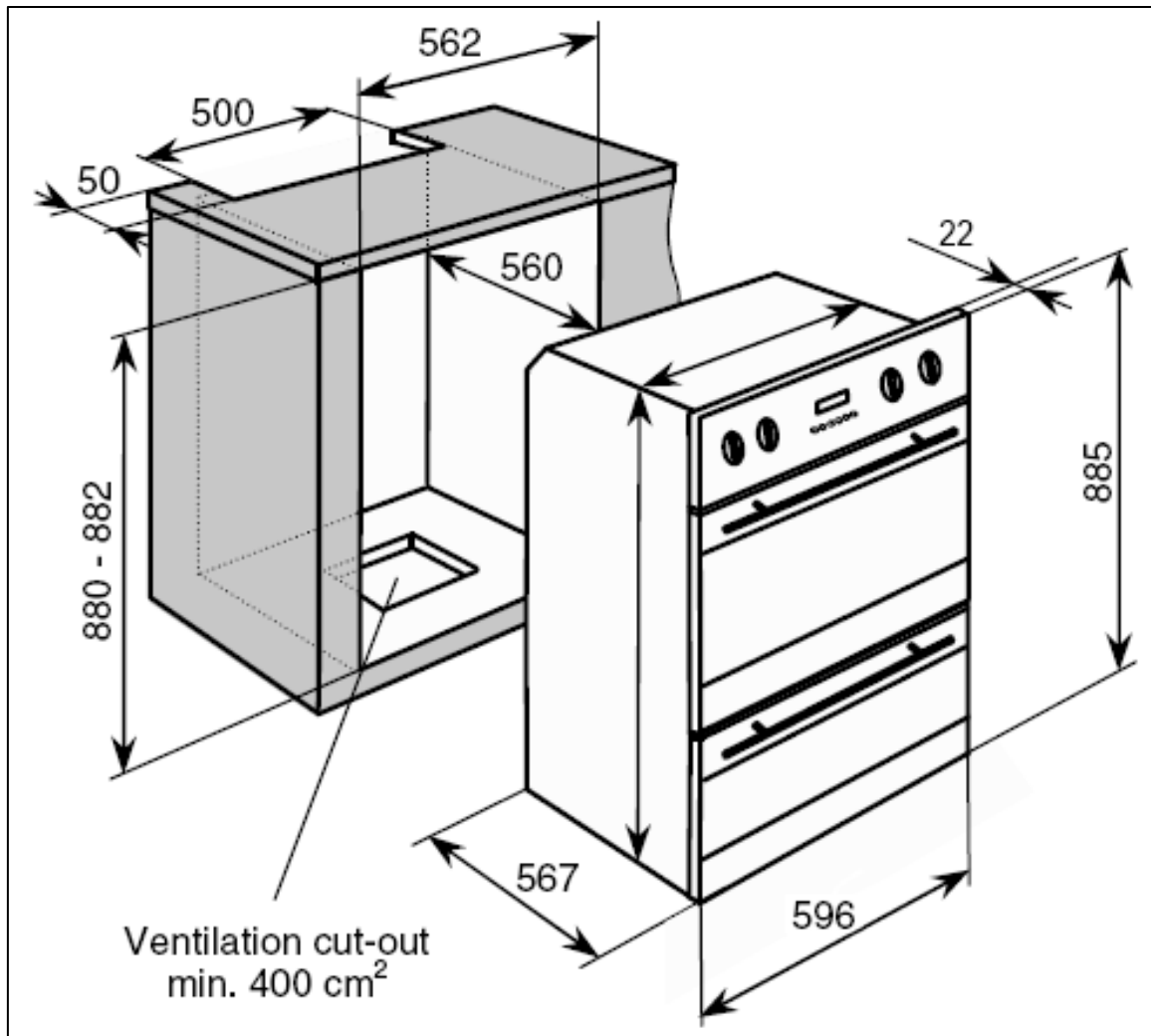

- Ensure that the aperture that you will be fitting the oven into is of the size given in the above diagram.
- The oven must be fitted into a housing unit with the ventilation cut-outs shown in the “Ventilation requirements” section on the next page.
- Ensure that the rear panel of the furniture housing unit has been removed.

## Ventilation requirements

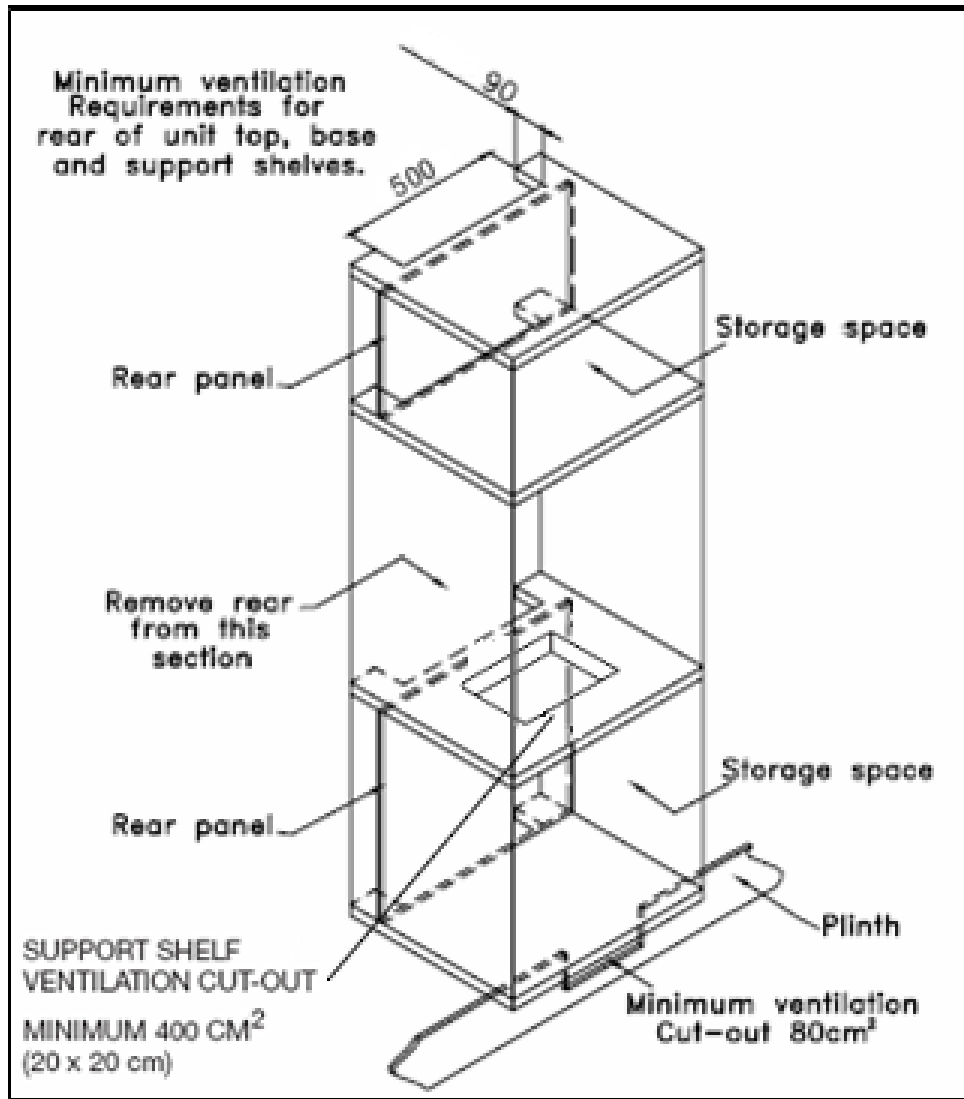

(Figure shows the ventilation and cut-out requirements for the installation of the appliance into a tall housing unit).

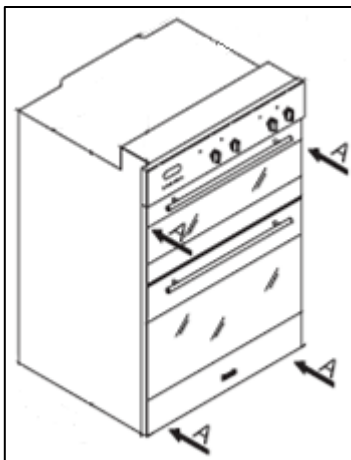

- Ensure that the oven has been securely fixed into the housing unit. The fixing of the oven into the housing is made by using four screws. These should be screwed through the oven cabinet and into the housing unit.

## **My appliance isn't working correctly**

- **The ovens aren't coming on.**
  - \* Check that the oven is in manual operation mode.
  - \* Check that you have selected a cooking function and a cooking temperature.
- **There appears to be no power to the ovens.**
  - \* Check that the appliance has been connected to the electrical mains supply correctly.
  - \* Check that the mains fuses are in working order.
  - \* Check that the operating instructions for setting the time of day and putting the appliance into manual operation mode have been followed.
- **The grill function works but the main oven does not.**
  - \* Check that you have selected the correct cooking function.
- **The grill and top oven element is not working, or cuts out for long periods of time during use.**
  - \* Allow the oven to cool for approximately 2 hours. Once cool, check whether the appliance is again working properly.
- **My food is not cooking properly**
  - \* Ensure that you are selecting the correct temperature and the correct cooking function for the food that you are cooking. It may be appropriate to adjust your cooking temperature by plus or minus 10°C, to achieve the best cooking results.
- **My food is not cooking evenly**
  - \* Check that the oven has been installed correctly and is level.
  - \* Check that the correct temperatures and shelf positions are being used.

- **The oven light is not working**
  - \* Refer to page 24 and follow the “Replacing the oven bulb” section.
- **I am getting condensation in my oven**
  - \* Steam and condensation is a natural by product of cooking any food with high water content, such as frozen food, chicken etc.
  - \* You may get condensation in the oven cavity and forming between the oven door glasses. This is not necessarily a sign that the oven is not working correctly.
  - \* Do not leave food in the oven to cool after it has been cooked and the oven has been switched off.
  - \* Use a covered container, where practical, when cooking to reduce the amount of condensation that forms.



**IMPORTANT: If your appliance appears not to be operating correctly, then you should disconnect it from your mains supply and then contact Baumatic Customer Care on telephone number (0118) 933 6911.**

**DO NOT ATTEMPT TO REPAIR THE APPLIANCE YOURSELF.**

Please note that if an engineer is asked to attend whilst the product is under guarantee and finds that the problem is not the result of an appliance fault, then you may be liable for the cost of the call out charge.

**The appliance must be accessible for the engineer to perform any necessary repair. If your appliance is installed in such a way that an engineer is concerned that damage will be caused to the appliance or your kitchen, then he will not complete a repair.**

**This includes situations where appliances have been tiled in, sealed in with sealant, have wooden obstructions placed in front of the appliance, like plinths. Or any installation other than the one specified by Baumatic Ltd. has been completed.**

Please refer to the conditions of guarantee that appear on the warranty card that you receive with the appliance.



**United Kingdom**

Baumatic Ltd.,  
Baumatic Buildings,  
6 Bennet Road,  
Reading, Berkshire  
RG2 0QX  
United Kingdom

**Sales Telephone**

(0118) 933 6900

**Sales Fax**

(0118) 931 0035

**Customer Care Telephone**

(0118) 933 6911

**Customer Care Fax**

(0118) 986 9124

**Spares Telephone**

(01235) 437244

**Advice Line Telephone**

(0118) 933 6933

**E-mail:**

sales@baumatic.co.uk  
customercare@baumatic.co.uk  
spares@baumatic.co.uk  
technical@baumatic.co.uk

**Website:**

www.baumatic.co.uk

**Republic of Ireland**

01- 6266 798

**Czech Republic**

Baumatic CR spol s.r.o.  
Amperova 495  
46215, Librec  
Czech Republic

+420 800 185 263

www.baumatic.cz

**Slovak Republic**

Baumatic Slovakia, s.r.o.  
Skultetyho 1  
831 04 Bratislava 3  
Slovakia

+421 255 640 618

**Germany**

Baumatic GmbH  
Janderstrasse 9  
Mannheim, 68199  
Germany

+4962 112 9190

www.baumatic.de

**Italy**

Baumatic Italia S.R.L.  
Via Caltana 129  
Campodarsego (Padova), 35011  
Italy

+3904 9920 2297

www.baumatic.it

**Holland**

Baumatic Benelux B.V.  
Grindzuigerstraat 22  
1333 MS ALMERE  
The Netherlands

+3136 549 1555

www.baumatic.nl





