

**BCS460SS 46 cm combi
steamer touch
control oven.**

INSTRUCTION MANUAL



User Manual for your Baumatic

BCS460SS

46 cm combi steamer touch control oven with personalised recipes.



NOTE: This User Instruction Manual contains important information, including safety & installation points, which will enable you to get the most out of your appliance. Please keep it in a safe place so that it is easily available for future reference; for you or any person not familiar with the operation of the appliance.

Contents

Environmental note	4
Important safety information	5-7
Specifications	8-9
Product and aperture dimensions	9
Cooling fan	9
Product specifications	9
Standard accessories	9
Electrical details	9
Description of the oven and accessories	10-11
Control panel	11
Using your oven for the first time	11-15
Before first use	11-12
Setting the time of day	12
Oven burn off	12
Setting the minute minder	13
Setting the duration function	13-14
Setting the start and end time function	14-15
Oven function and temperature selection	15-21
Oven functions	16-17
Water hardness	17-18
Cooking with steam	18
Adding hot air + steam cooking mode	18-19
Cooking guidelines	19
Warnings	20
Accessories	20-21
Cooking charts	21-27
Memorising cooking programmes	24
Recalling saved cooking programmes	24-25
Deleting saved cooking programmes	25
Cooking with the food probe	25-27
Menu options	27-30
Cleaning and maintenance	30-37
Oven cavity cleaning cycle	31-32
Boiler descaling	32-33
Boiler wash	33-34
Removing the side racks	34-35
Replacing the oven bulb	35
Removing the oven door for cleaning	36-37
Installation	37-39
Electrical connection	37-38
Installing the oven into the kitchen cabinet	38-39
Ventilation requirements	39
My appliance isn't working correctly	40-42
Contact details	43

Environmental note

This appliance is marked according to the European directive 2002/96/EC on Waste electrical and Electronic Equipment (WEEE). By ensuring this product is disposed of correctly, you will help prevent potential negative consequences for the environment and human health, which could otherwise be caused by inappropriate waste handling of this product.

The symbol  on the product, or on the documents accompanying the product, indicates that this appliance may not be treated as household waste. Instead it shall be handed over to the applicable collection point for the recycling of electrical and electronic equipment.

Disposal must be carried out in accordance with local environmental regulations for waste disposal.

For more detailed information about treatment, recovery and recycling of this product, please contact your local city office, your household waste disposal service or the shop where you purchased the product.



- The packaging materials that Baumatic uses are environmentally friendly and can be recycled.
- Please discard all packaging material with due regard for the environment.

IMPORTANT SAFETY INFORMATION



Your safety is of the utmost importance to Baumatic. Please make sure that you read this instruction booklet **before** attempting to install or use the appliance. If you are unsure of any of the information contained in this booklet, please contact the Baumatic Technical Department.

General Information

- This appliance is designed for domestic household use and can be built into a standard kitchen cabinet or housing unit.
- **IMPORTANT:** You **must not** install the appliance in a location where the ambient temperature will fall below 5°C.
- **IMPORTANT:** The adjacent furniture or housing and all materials used in the installation **must** be able to withstand a minimum temperature of 85°C above the ambient temperature of the room it is located in, whilst in use.
- Certain types of vinyl or laminate kitchen furniture are particularly prone to heat damage or discolouration at temperatures below the guidelines given above.
- Any damage caused by the appliance being installed in contravention of this temperature limit, or by placing adjacent cabinet materials closer than 4mm to the appliance, **will be the liability of the owner.**
- For use in **leisure accommodation vehicles**, please refer to the appropriate information given in the installation instructions for this appliance.
- The use of this appliance for any other purpose or in any other environment without the express agreement of Baumatic Ltd. will invalidate any warranty or liability claim.
- Your new appliance is guaranteed against electrical or mechanical defects, subject to certain exclusions that are noted in Baumatic's Conditions Of Guarantee. The foregoing does not affect your statutory rights.
- **Repairs may only be carried out by Baumatic Service Engineers or their authorised service agent.**

Warning and safety instructions

- This appliance complies with all current European safety legislation. Baumatic do wish to emphasise that this compliance does not remove the fact that the appliance surfaces ***will become hot during use and retain heat after operation.***

Child Safety

- Baumatic strongly recommend that babies and young children are prevented from being near to the appliance and not allowed to touch the appliance ***at any time.***
- If it is necessary for younger family members to be in the kitchen, please ensure that they are kept under close supervision at all times.

General Safety

- ***Do not*** place heavy objects on the oven door or lean on the oven door when it is open, as this can cause damage to the oven door hinges.
- ***Do not*** leave heated oil or fat unattended, as this is a fire risk.
- ***Do not*** place pans or baking trays directly on the base of the oven cavity, or line it with aluminium foil.
- ***Do not*** allow electrical fittings or cables to come into contact with areas on the appliance that get hot.
- ***Do not*** use the appliance to heat the room it is located in or to dry clothing.
- ***Do not*** install the appliance next to curtains or soft furnishings.
- ***Do not*** attempt to lift or move cooking appliances by using the oven door or handle, as this may cause damage to the appliance or result in injury to the person lifting the appliance.

Cleaning

- Cleaning of the oven should be carried out on a regular basis.
- Great care should be taken whilst using this appliance and when following the cleaning procedure.

- **IMPORTANT:** The appliance must be disconnected from the mains before following the cleaning procedure.

Installation



This appliance must be correctly installed by a suitably qualified person, strictly in accordance with the manufacturer's instructions.

- ***Baumatic Ltd. declines any responsibility for injury or damage, to person or property, as a result of improper use or installation of this appliance.***
- Heat, steam and moisture will be created during use of the appliance, take care to avoid injury and ensure that the room is adequately ventilated. If the appliance is going to be used for prolonged periods of time, then additional ventilation may be required.
- Please consult with your qualified installer if you are in any doubt about the amount of ventilation that you will require.

Declaration of conformity

- In the parts destined to come into contact with foodstuffs, this appliance is in accordance with the requirements of the EC directive 89/109 transposed in the Italian Legislative Decree No. 108 of 25/01/92.
 - **CE:** Appliance conforming to the European directives 89/336/EEC, 93/68/EEC, 73/23/EEC and subsequent revisions and "RoHS" directive 2002/95/CE.*
 - The manufacturer declares that the oven is built using certified materials and requires the appliance to be installed in accordance with the standards currently in force. This appliance must be used by a trained person for domestic purposes only.
- * The RoHS directive stands for "the restriction of the use of certain hazardous substances in electrical and electronic equipment". This directive bans the placing on the EU market of new electrical and electronic equipment containing more than the agreed levels of lead, cadmium, mercury, hexavalent chromium, polybrominated biphenyl (PBB) and polybrominated diphenyl ether (PBDE) flame retardants.

Specifications

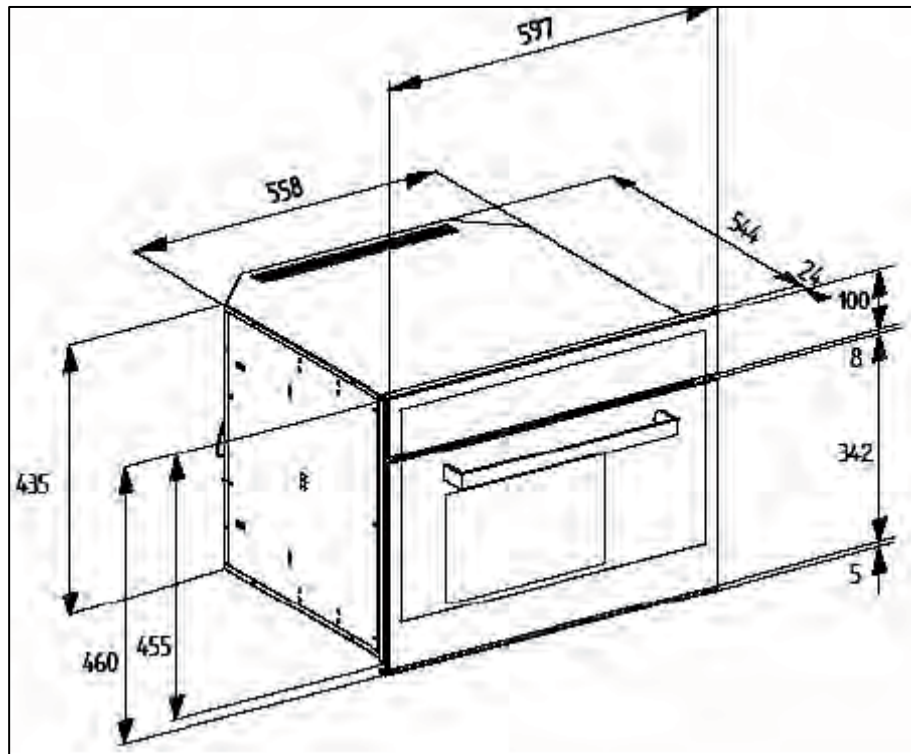
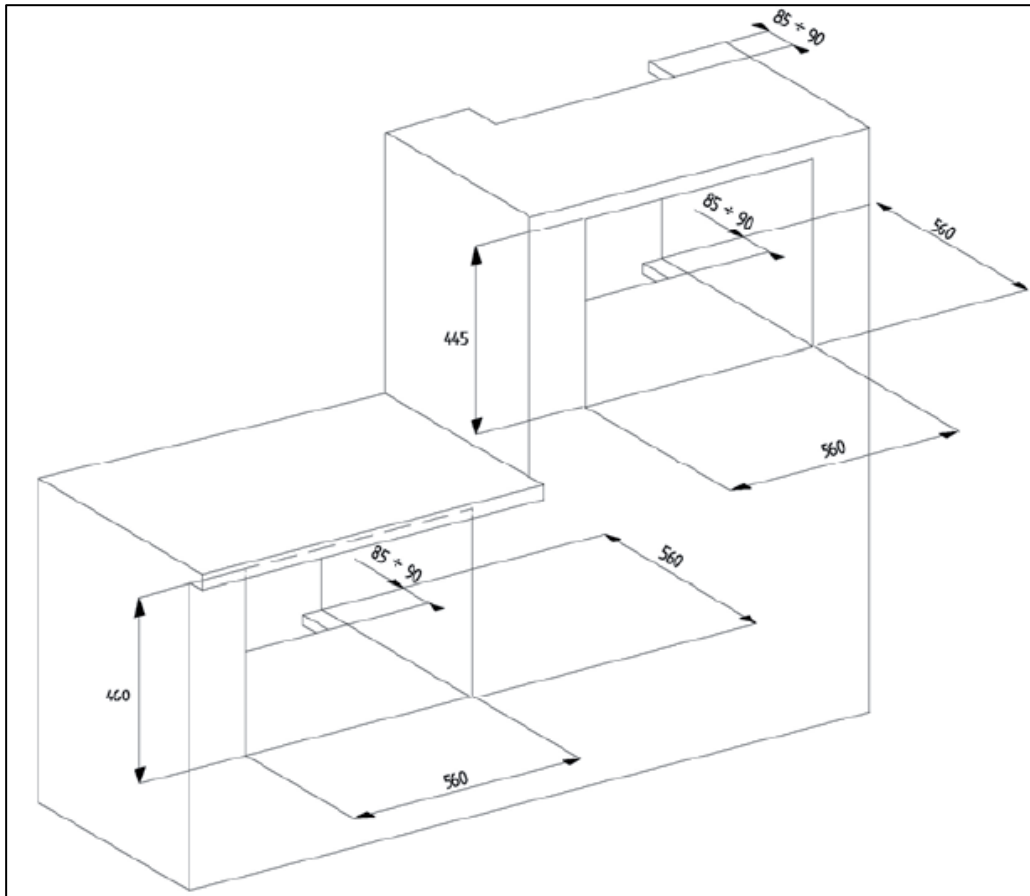

Product dimensions

Height: 460 mm
Width: 597 mm
Depth: 544

Aperture dimensions

Height: 460 mm (built under) / 445 mm (built in)
Width: 560 mm
Depth: 560 mm

Cooling fan

- A tangential cooling fan is fitted inside of this appliance, to make the internal temperature of the oven stable and the external surface temperature lower.

Product specifications

- Energy efficiency class: A
- Gross oven capacity: 31litres
- Net oven capacity: 27 litres
- Touch control operation
- Multi language text display (English, French, Italian, Spanish, Portuguese, Czech, Dutch, Danish, Russian and German)
- **50 preset recipes**
- Electronically controlled thermostat
- Cooling fan
- Safety lock
- Triple-glazed removable door

Standard accessories

- 1 x Removable side racks
- Safety shelf
- 2 x Inox perforated deep trays
- Food probe

Electrical details

Rated Voltage:	220 - 240 Vac 50 - 60 Hz
Supply Connection:	13 A (double pole switched fused outlet with 3mm contact gap)
Max Rated Inputs:	2.2 kW
Mains Supply Lead:	3 x 1.5mm ²
Oven Light Bulb:	25 W/ E14 300°C screw type pigmy

For future reference please record the following information which can be found on the Rating Plate and the date of purchase which can be found on your sales invoice. The rating plate for your oven can be located by opening the oven door and looking on the right hand side of the oven chassis.

Model Number

Serial Number

Date of Purchase

Description of the oven and accessories

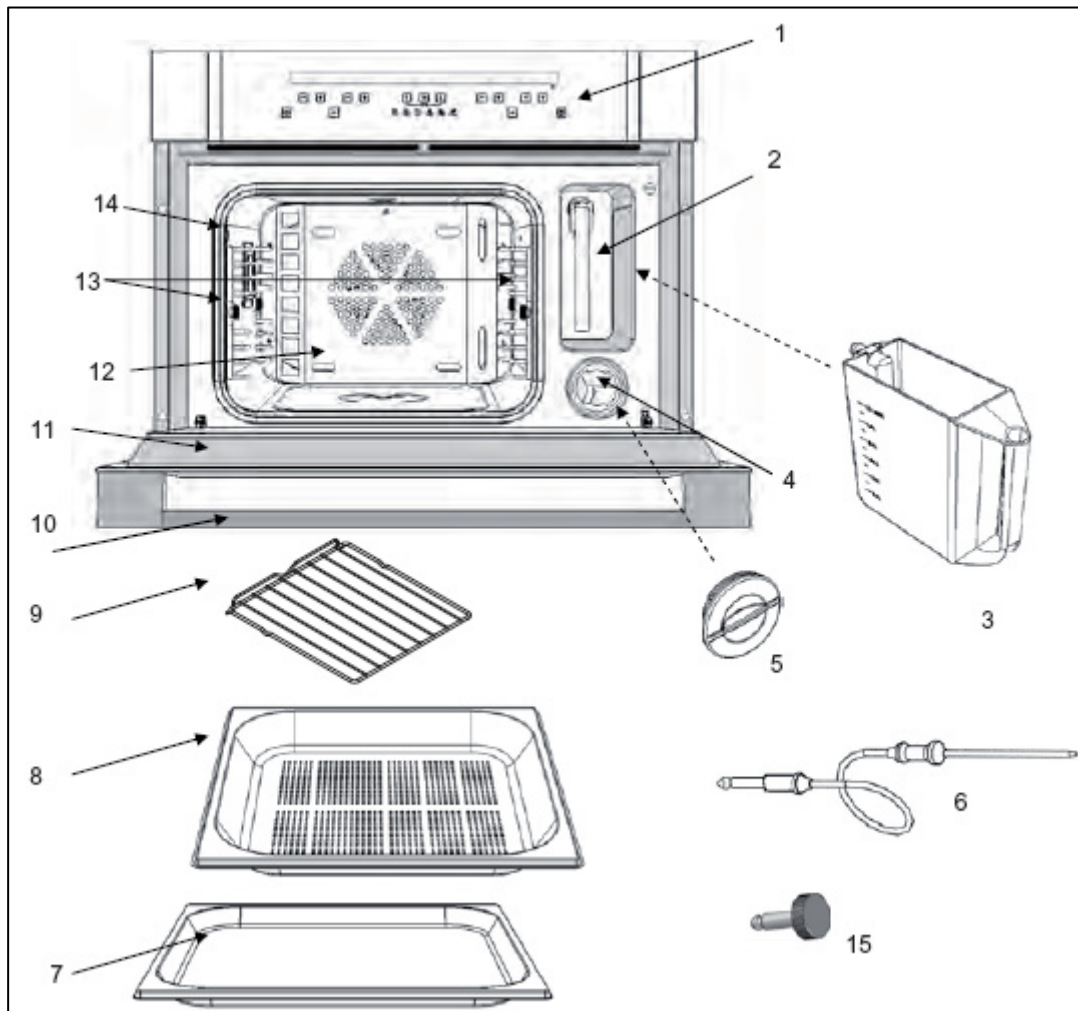

- 1) Control panel
- 2) Water jug compartment
- 3) Water jug
- 4) Filter compartment
- 5) Filter cap
- 6) Food / temperature probe
- 7) Solid drip tray
- 8) Perforated tray

- 9) Grill
- 10) Handle
- 11) Door
- 12) Oven cavity
- 13) Side racks
- 14) Food probe connector
- 15) Connector cap (to be inserted on the connector when probe is not in use).

Control Panel

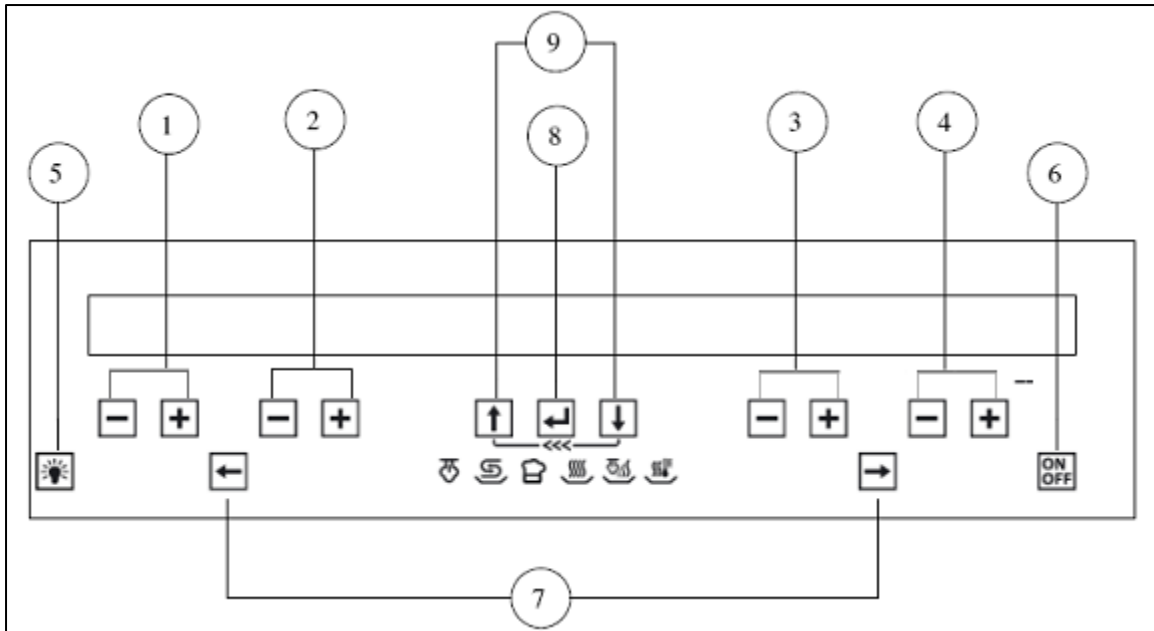

1. Oven function thermostat buttons
2. Food probe thermostat buttons
3. Programmed cooking time selection buttons
4. Timer/language selection buttons
5. Oven light ON/OFF button
6. Oven ON/OFF button
7. Oven function selection buttons
8. Confirmation button
9. Oven setting selection buttons

Using your oven for the first time

Before first use

- ***The appliance should be disconnected from your mains supply before commencing any cleaning process.***
- Thoroughly clean the oven cavity with warm soapy water, using either a sponge or soft cloth. No abrasive cleaners should be used. You should then dry the oven cavity before connecting your appliance to your mains supply.

- Before switching on the oven, check that the connector cap is inserted in the right place for cooking with or without the probe. **The oven does not start cooking if any of the two accessories are not inserted.**
- **IMPORTANT:** The installation instructions contained in this booklet **MUST** be followed. The installation **MUST** be completed by a qualified installer.

Setting the time of day

- When the appliance is initially connected to the power supply, the display will light up and will show the message "WAIT". **DO NOT** touch any other button until the time selection menu appears. **It is normal for the tangential fan to turn on and then shut off for a few moments.**
- Use the timer selection buttons **(4)** to set the time of day. If you hold down these buttons, then the timer will scroll more rapidly.
- Once the display shows the correct time of day, press the confirmation button **(8)** to confirm your choice.
- Once you have set the time of day, press the oven ON/OFF button **(6)** again. The display will show **← → COOKING SELECTION** and **↑ ↓ MENU**.

Oven burn off

- To remove any residue from the oven that may have been left from the manufacturing process, you should select the Professional Cooking function and set the temperature to 230°C. You should read page 16 to see how to set a cooking function and temperature.
- It is perfectly normal for a smell to be produced during this process.
- You should make sure that any windows in the room are left open during this process.
- It is advisable for you not to remain in the room whilst the burning off process is taking place.
- You should leave the oven on maximum setting for 30 – 40 minutes.

Setting the minute minder

You are able to set the minute minder, regardless of whether an oven function has been selected. You can set a period of time using the minute minder and an alarm will sound when this period of time has elapsed.

- Press the oven ON/OFF button **(6)**.
- Use the timer selection buttons **(4)** to switch on the timer.
- A 🔔 symbol will begin to flash, the display will show the word ALARM and the digits 00.00 will appear.
- Use the timer selection buttons **(4)** to adjust the countdown time between 00h01m and 23h59m.
- Release the timer selection buttons **(4)** and after a few moments, the countdown will begin.
- Whilst the countdown time is in operation, the display will continue to show the 🔔 symbol, the oven will return to showing the time of day.
- It is possible to adjust the countdown time whilst it is in progress. To do this press one of the timer selection buttons **(4)**, the 🔔 will begin to flash. Use the timer selection buttons **(4)** to adjust the countdown time and then release them.
- When the countdown is complete, the oven will emit an acoustic signal for 5 minutes. The display will show the word ALARM, 00.00 and the 🔔 symbol will flash. To silence the acoustic signal, press any key apart from the oven ON/OFF button **(9)**.
- **Important:** *If you have an oven function in progress, the oven will continue to heat when the audible signal sounds you will need to switch the oven off manually, using the ON/OFF button.*
- If you want to cancel the timer setting whilst the countdown is in progress, press the timer selection buttons **(4)** simultaneously. The 🔔 symbol will go out.

Setting the duration function

This function will allow you to set a countdown time similar to the minute minder function. However the oven will no longer continue to heat, once the countdown period has elapsed.

- Press the oven ON/OFF button **(6)**.

- Select an oven function by using the oven function selection buttons **(7)**.
- Once the display shows the oven function that you require, press the confirmation button **(8)** to confirm your choice.
- Each oven function has a preset temperature assigned to it; however it is possible to adjust this preset temperature using the oven function thermostat buttons **(1)**.
- Use the programmed cooking time selection buttons **(3)** to set the length of time that you want the oven to cook for.
- The timer will initially count in minutes and seconds, and then if you continue to increase the cooking time, it will then count in hours and minutes. The maximum cooking time that can be set is 10 hours.
- Press the confirmation button **(8)** to confirm your cooking time. After a few moments, the countdown will begin.
- When the countdown is complete, the oven will emit an acoustic signal for 5 minutes and show COOKING FINISHED on the display.
- Press the oven ON/OFF button **(6)** to cancel the audible signal and switch the oven off.

Setting the start and end time function

This function will allow you to set a time in the future that the oven will switch on at and a time that the oven will switch off at.

- Press the oven ON/OFF button **(6)**.
- Select an oven function by using the oven function selection buttons **(7)**.
- Once the display shows the oven function that you require, press the confirmation button **(8)** to confirm your choice.
- Each oven function has a preset temperature assigned to it; however it is possible to adjust this preset temperature using the oven function thermostat buttons **(1)**.
- Use the programmed cooking time selection buttons **(3)** to set the length of time that you want the oven to cook for.
- The timer will initially count in minutes and seconds, and then if you continue to increase the cooking time, it will then count in

hours and minutes. The maximum cooking time that can be set is 10 hours.

- Immediately press the oven setting selection buttons **(9)** until END OF COOKING appears on the display, press the confirmation button **(8)** to confirm your choice.
- When the message SET TIME appears on the display, use the programmed cooking time selection buttons **(3)** to set the time of day that you want the oven to switch off at. Press the confirmation button **(8)** to confirm your choice.
- A message will appear on the display every 15 seconds, showing the time remaining until the oven switches on.
- If you want to delete the programmed cooking time, press the programmed cooking time selection buttons **(3)** simultaneously.
- When the countdown is complete, the oven will emit an acoustic signal for 5 minutes and show COOKING FINISHED on the display.
- Press the oven ON/OFF button **(6)** to cancel the audible signal and switch the oven off.

Oven function and temperature selection





This option allows you to select the preset cooking functions that the oven offers and the temperature that the oven will cook at.



- Select an oven function by using the oven function selection buttons **(7)**.
- Once the display shows the oven function that you require, press the confirmation button **(8)** to confirm your choice.
- Each oven function has a preset temperature assigned to it; however it is possible to adjust this preset temperature using the oven function thermostat buttons **(1)**.
- Press the confirmation button **(8)** to commence the oven function that you selected previously. The phrase COOKING IN PROGRESS will appear on the display.
- If you do not press the confirmation button **(8)** within 5 minutes, then the oven will shut off.
- The degree symbol "°" will flash on the display; this indicates that the oven is heating to the temperature that has been set.

When the set temperature is reached, the degree symbol will remain fixed.

- You should not place food in the oven until the degree symbol “°” has stopped flashing.
- If you want to change the oven function, use the oven functions selection button **(7)**, and then press the confirmation button **(8)** to confirm your choice.
- Press the oven ON/OFF button **(6)** to switch the oven off.

Oven functions

Function name and symbol	Function description	Min. – max temp.	Default temp.	Food probe default temp.
STEAM COOKING 	Steam from the boiler flows into the oven cavity. The steam heats the oven cavity and cooks the food. This cooking mode is ideal for cooking any type of vegetables. It preserves the colour and taste of the food.	40 – 100°C	100°C	70°C
REGENERATION 	Steam and hot air heat the oven cavity. This allows the food to be cooked quickly but without becoming dried out. There is a circular heating element and a fan that distributes the heat evenly. This cooking mode is suitable for heating previously cooked food, pre-cooked food or frozen food. *	60 – 100°C	80°C	70°C
PROFESSIONAL COOKING 	The cooking is carried out in phases, with steam cooking being followed by hot air cooking. This cooking mode is suitable for raising any type of dough, or for cooking bread and focaccia bread. *	100 – 230°C	205°C	70°C
HOT AIR COOKING 	The air inside the oven cavity is heated by a circular heating element. A fan ensures that the hot air is distributed uniformly throughout the cavity.	40 – 230°C	175°C	70°C
HOT AIR + STEAM	The same as hot air cooking mode, but with the	80 – 230°C	175°C	70°C

	option of adding steam to the oven cavity manually by pressing the confirmation button (8) . You can stop the steam by pressing the same button again. **			
LOW TEMPERATURE 	Low temperature cooking, ideal for slow cooking over a relatively long period of time. Ideal for cooking meat tenderly and delicately. ***	60 - 100°C	90°C	70°C

* After using the appliance in these cooking modes, you must allow time for the oven cavity to cool properly before selecting these modes of cooking again. Otherwise the oven may not generate steam properly.

** After 15 minutes, the steam will be shut off automatically by the oven.

*** The meat probe must be used whilst using low temperature cooking mode.

Water hardness

- o Baumatic recommend that you fill the water jug with distilled water. If this is unavailable then cold drinking water should be used.
- o The oven can be adjusted to take into account the hardness of the water that you are filling the water jug with.

Water hardness °fH	Water hardness °dH
16 – 35 °fH Average water	0 – 8 °dH Average water
0- 15 °fH Very soft water	9 – 20 °dH Very soft water
36 – 50 °fH Very hard water	21 – 28 °dH Very hard water

- o The left hand column shows water hardness measured in French degrees. The right hand column shows water hardness measured in German degrees.
- o Your oven is automatically set to the AVERAGE WATER setting. If your water supply is harder or softer than the figures quoted for the AVERAGE WATER SETTING, then you must adjust the oven settings to take this into account.
- o To adjust the water hardness setting, switch the oven on using the oven ON/OFF button **(6)**. ← → SELECT COOKING ↓ MENU will appear on the display.

- Use the oven setting selection buttons **(9)** to select SETTINGS. Press the confirmation button **(8)** to confirm your choice.
- Use the oven setting selection buttons **(9)** to select WATER HARDNESS. Press the confirmation button **(8)** to confirm your choice.
- Use the oven setting selection buttons **(9)** to select VERY SOFT, AVERAGE or VERY HARD. Press the confirmation button **(8)** to confirm your choice.

Cooking with steam



IMPORTANT: This process **MUST** be followed when you are using a cooking function that involves steam.

- Fill the water jug with distilled water, or if this is unavailable cold drinking water.
- Fill the water jug up to the 1.2 litre mark. **DO NOT** fill the jug right to the top. Otherwise the water that is pumped back into the jug at the end of a cooking cycle may overflow.
- Insert the water jug into the water jug compartment.
- Push the water jug down completely, this ensures a perfect seal between the tube located in the jug and the hydraulic circuit inside of the oven.
- **ALWAYS** ensure that the **NON** perforated drip pan is inserted underneath the perforated drip pan. This will catch any condensation, juice or food that falls from the perforated drip pan.
- If you are using a cooking function that doesn't involve steam, then you can leave the water jug inside of the water jug compartment. It will not affect the cooking abilities of the oven.

Adding steam during hot air + steam cooking mode

The hot air + steam cooking mode allows you to add steam at any time during cooking. This allows you to maintain the right degree of humidity inside of the oven cavity.

- Once the hot air + steam cooking mode and a temperature has been selected, the message PRESS ↵ TO ADD STEAM will appear on the display.

- If you press the confirmation button **(8)** the  symbol will appear on the display, to indicate that the steam generator is active.
- After a few moments, steam will begin to flow into the oven cavity. The steam is introduced into the cavity periodically, with brief pauses in between for up to 15 minutes.
- When the  symbol goes out, the steam generator is no longer in operation.
- It is possible to switch off the steam generator before the 15 minute period has elapsed, by pressing the confirmation button **(8)** again. PRESS  TO STOP STEAM will appear on the display to remind you that it is possible to do this.

Cooking guidelines

- Please refer to the information given on food packaging for guidance on cooking temperatures and times. Once familiar with the performance of your appliance, temperatures and times can be varied to suit personal preference.
- If you are using the hot air cooking function, then you should follow the information given on the food packaging for this particular mode of cooking. It may be listed as fan oven cooking on the food packaging.
- Make sure that frozen foods are thoroughly thawed before cooking, unless the instructions on the food packaging advise that you can "cook from frozen".
- You should pre-heat the oven and not place food inside of it until the pre-heating period is over. You can choose not to pre-heat when using the hot air cooking function; however you should extend the cooking time given on the food packaging by approximately ten minutes.
- Before cooking, check that any unused accessories are removed from the oven.
- Place cooking trays in the centre of the oven and leave gaps between the trays to allow air to circulate.
- Try to open the door as little as possible to view the dishes.
- The oven light will remain on during cooking.

Warnings

- Keep the oven door closed when using any oven function.
- Do not use aluminium foil to cover the trays supplied with the oven.
- You should also never line the base of your oven with aluminium foil.
- During cooking, never place pans or cookware directly onto the bottom of your oven. They should always be placed on the shelves provided.
- **Important:** Be careful when opening the door, to avoid contact with hot parts and steam.
- The drip pan handle should only be used to reposition the drip tray and **NOT** for removing it from the oven cavity. When removing the drip tray, you should **ALWAYS** use an oven glove.
- The drip pan handle should not be left in position when the appliance is switched on.

Accessories

The accessories supplied with the oven, allow you to get the optimum performance from your appliance on the various cooking modes that are available.

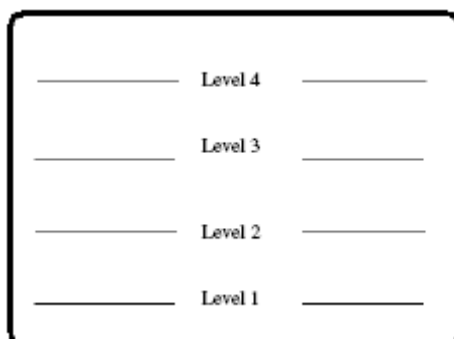

- The drip pan and shelf accessories can be placed on various levels by positioning them in the side racks located inside of the oven.
- This allows you to select the most suitable level for cooking, depending on what you are cooking and what cooking mode

you are using. The cooking charts will give some guidance on this.



- The drip pan is a tray with raised edges, which can be used as a support surface for any single level cooking container.

- It can also be used as a drip tray, for collecting cooking juices or fat that may be generated during the cooking process.
- When cooking fatty dishes, we recommend that you place some water in the drip pan, to prevent fat from burning and producing unpleasant odours or smoke.

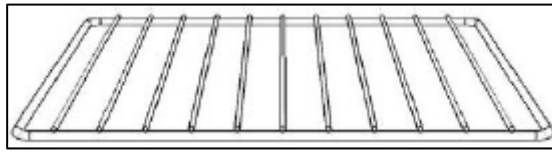

- The shelf should be used as a support surface; it should normally be placed in positions 2, 3 or 4.

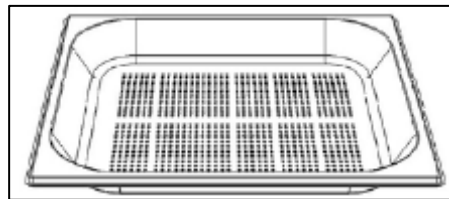



- The perforated drip pan is mainly used for steam cooking fresh or frozen vegetables, fish etc.
- Position the perforated drip pan on level 2 or 3. You must insert the drip pan below the perforated drip pan, to collect any liquid that is released from the food during the cooking process.

Cooking charts

The cooking times below are intended as a guide only; you must adjust them depending on your own personal preferences and the size of the dishes that you are cooking.





Bread/pizza recipe list

<i>Dish</i>	<i>Cooking chamber temperature °C</i>	<i>Cooking time (hr:min)</i>	<i>Level (from bottom)</i>	<i>Cooking cycle</i>
Savoury focaccia bread	220	00:25	3	
Bread	220	00:35	3	
Pizza	230	00:25	3	

Timbales recipe list

Dish	Cooking chamber temperature °C	Cooking time (hr:min)	Level (from bottom)	Cooking cycle
Cannelloni	190	01:00	3	
Lasagne	180	01:20	3	
Asparagus timbale	180	01:10	3	
Potato timbale	180	01:20	3	
Courgette timbale	180	00:40	3	
Savoury tart	200	00:35	3	

Fish recipe list

Dish	Cooking chamber temperature °C	Cooking time (hr:min)	Level (from bottom)	Cooking cycle
Mussels and clams	100	00:30	3	
Plaice fillet	220	00:10	3	
Scorpion fish fillet	80	00:30	3	
Prawns and flat lobster	100	00:30	3	
Trout	100	00:35	3	

Desserts recipe list

Dish	Cooking chamber temperature °C	Cooking time (hr:min)	Level (from bottom)	Cooking cycle
Biscuits	150	00:35	3	
Yoghurt biscuits	170	00:15	3	
Plum cake	170	01:00	3	
Soufflés	200	00:35	3	
Apple pie	170	01:00	3	
Sponge	170	00:40	3	

cake				
------	--	--	--	--

Meat recipe list

The cooking modes listed have been determined for pieces of meat weighing about 1 kg.

Dish	Cooking chamber temperature °C	Food probe temperature °C	Level (from bottom)	Cooking cycle
Haunch of pork	90	70	3	
Beef rump	90	70	3	
Veal rump	90	68	3	
Roast pork	90	72	3	
Pork neck	100	75	3	
Medium chop	75	62	3	
Rare chop	70	55	3	
Medium beef filet	75	62	3	
Rare beef filet	70	57	3	
Beef roll	80	65	3	
Turkey breast	90	70	3	
Roast beef	80	62	3	
Rare roast beef	70	57	3	
Beef shoulder	85	70	3	
Veal shoulder	90	72	3	

Vegetables recipe list

Dish	Cooking chamber temperature °C	Cooking time (hr:min)	Level (from bottom)	Cooking cycle
Asparagus	100	00:35	3	
Broccoli	100	00:30	3	
Carrots	100	00:35	3	
Brussels	100	00:35	3	

sprouts				
Cauliflower	100	00:40	3	
Swiss chard stalks	100	00:35	3	
Green beans	100	00:40	3	
Fennel	100	00:40	3	
Potatoes	100	00:50	3	
Peppers	100	00:25	3	
Leeks	100	00:40	3	
Rice	100	00:35	3	
Celery	100	00:35	3	
Spinach	100	00:20	3	
Zucchini	100	00:30	3	

Memorising cooking programmes

Your oven can memorise oven functions, temperatures and timings that you have used previously.

- After you have set a cooking function and temperature, it is possible to get the oven to memorise this setting. You can also memorise a food probe temperature or the cooking time.
- After setting the oven function and temperature, use the oven setting selection buttons **(9)** to scroll through the oven options, until you reach "SAVE COOKING CYCLE". Press the confirmation button **(8)** to confirm your choice.
- Use the oven setting selection buttons **(9)** to scroll through the available memory slots for saving a cooking programme. You will see the text COOKING CYCLE NO. appear on the display. Press the confirmation button **(8)** to confirm your choice.
- The word DONE will appear on the display to advise that you have successfully memorised a cooking programme.
- If the word DONE does not appear on the display, then this means that all of the available memory slots are full. You will need to delete a saved cooking programme before you can save a new one.

Recalling saved cooking programmes

- To recall a saved cooking programme, switch the oven on using the oven ON/OFF button **(6)**. ← → SELECT COOKING ↓ MENU will appear on the display.
- Use the oven setting selection buttons **(9)** until RECIPES appears on the display. Press the confirmation button **(8)** to confirm your choice.

- Use the oven setting selection buttons **(9)** until YOUR OWN RECIPES appears on the display. Press the confirmation button **(8)** to confirm your choice.
- Use the oven setting selection buttons **(9)** until LOAD COOKING CYCLE appears on the display. Press the confirmation button **(8)** to confirm your choice.
- Use the oven setting selection buttons **(9)** until the cooking cycle number that you want to select appears on the display. Press the confirmation button **(8)** to confirm your choice. If the word EXIT appears, it means that no personal recipes have been saved.

Deleting saved cooking programmes

- To delete a saved cooking programme, switch the oven on using the oven ON/OFF button **(6)**. ← → SELECT COOKING ↓ MENU will appear on the display.
- Use the oven setting selection buttons **(9)** until RECIPES appears on the display. Press the confirmation button **(8)** to confirm your choice.
- Use the oven setting selection buttons **(9)** until YOUR OWN RECIPES appears on the display. Press the confirmation button **(8)** to confirm your choice.
- Use the oven setting selection buttons **(9)** until DELETE COOKING CYCLE appears on the display. Press the confirmation button **(8)** to confirm your choice.
- Use the oven setting selection buttons **(9)** until the cooking cycle number that you want to delete appears on the display. Press the confirmation button **(8)** to confirm your choice.
- When the cooking programme has been deleted, the word DONE will appear on the display.

Cooking with the food probe

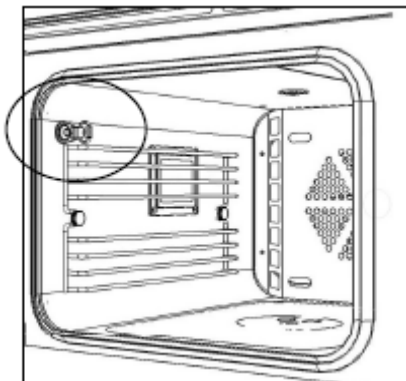

You can cook your favourite dishes using the food probe. The sensor in the probe detects the internal temperature of the food during cooking. It will indicate when the set core temperature has been reached and the meat has been cooked to satisfactorily.

- Insert the probe into the hole in the upper left hand corner of the oven.
- The temperature sensor should be inserted into the food that you are going to cook. It senses the internal temperature of the food during cooking.
- ***IMPORTANT: The temperature sensor must be fully inserted into the middle of the food that you are cooking.***
- When you turn the oven on with the food probe connected to the oven, the display shows a bar symbol and the probe temperature (this is preset to 70°C). If this information does not show, then the food probe is not connected properly.

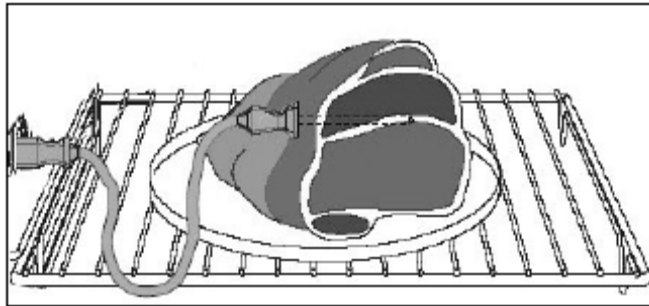

- Insert the tip of the food probe into the middle of the food, at its thickest point. In the case of poultry, it should not be placed into the middle area, as this is hollow. It should be placed between the belly and thigh.
- The temperature sensor must not touch any bones or inserted into any fatty tissue.
- Close the oven door.
- Use the oven function selection buttons **(7)** to select from the available cooking functions.
- Use the oven function thermostat buttons **(1)** to adjust the oven temperature.
- If you wish, use the food probe thermostat buttons **(2)** to modify the core temperature of the probe. You should use the table below as a guide to the temperature that you should set the food probe to.

Recommended core temperature values (°C)		
Beef	Roast beef / fillet of beef rare	45 – 50
	Medium – rare	55 – 65
	Well – done	70 – 80
	Beef roast	80 – 85
	Boiled fillet of beef 90 °C/195°F	90
Pork	Roast pork	80 – 85
	Back of pork	65 – 70
	Meat loaf	85
Veal	Roast veal	75 – 80
	Breast of veal, stuffed	75 – 80
	Back of veal, medium - rare	65 - 70
Venison	Leg of venison	75 – 80
	Back of hare / venison	65 - 70
Poultry	Chicken	85
	Goose	85 – 90
	Turkey / duck	80 – 85
	Duck breast	70
Lamb	Leg of lamb, medium – rare	55 – 65
	Lamb, well - done	75 - 80
Mutton	Leg of mutton, medium – rare	75 – 80
	Back of lamb, well - done	80
Bread	All types	90

- When the temperature that you have set using the food probe thermostat buttons **(2)** has been reached an audible signal will sound.
- It is possible to extend the cooking time at this point; however you must increase the core temperature of the food probe, using the food probe thermostat buttons **(2)**.
- Using an oven glove, you should carefully remove the food probe from the food that you are cooking and then check that the food is cooked to your satisfaction.
- **IMPORTANT: Before serving food, you must ensure that it is cooked all the way through.**
- To clean the food probe, simply wipe it over using a damp cloth.

Menu options

- To access the menu options, switch the oven on using the oven ON/OFF button **(6)**. ← → SELECT COOKING ↓ MENU will appear on the display.

- Use the oven setting selection buttons **(9)** to access the menu options; RECIPES, SETTINGS and EXIT. Press the confirmation button **(8)** to choose the menu option that you want to select.
- To exit menu options, you should use the oven setting selection buttons **(9)** until "Exit" appears on the display, and then press the confirmation button **(8)**.

Recipes

- Select the Recipes menu option using the confirmation button **(8)**. If you use the oven setting selection buttons **(9)**, a list of various types of food will appear on the display; meat, bread/pizza, fish, desserts, timbales, personal recipes and exit.
- A timbale is a layered dish cooked in a tall mould and then turned out onto a serving plate.
- Select the food type that you want by pressing the confirmation button **(8)**.
- Each food type has a sub-group of suggested recipes; you can cycle through these using the oven setting selection buttons **(9)**. When you get to the one that you desire, press the confirmation button **(8)** again to select this recipe.
- The recipe will activate the oven setting, a predetermined time and temperature. It is possible to modify the cooking time by using the programmed cooking time selection buttons **(3)** and the temperature using the oven function thermostat buttons **(1)**.

Settings

- Select the Settings menu option using the confirmation button **(8)**, Use the oven setting selection buttons **(9)** to cycle through various options.
- You should press the confirmation button **(8)** again to select the option that you want.

Language:

Lets you modify the language that the oven display shows.

- When the display shows the message "LANGUAGE", select the language that you wish the oven to operate in by using the language selection buttons **(4)**.

- Once the display shows your desired choice of language, press the confirmation button **(8)** to confirm your choice.

Setting the clock:

SET TIME- time of day adjustment.

DISPLAY CLOCK- show clock on the display (YES/NO selection).

NIGHT MODE- if selected the display is lit at a lower intensity between 10.00 pm until 7.00 am (YES/NO selection).

Setting keypad lock:

AUTOMATIC KEYPAD LOCK (YES/NO selection)

Buzzer:

You can select a LOW, MEDIUM or HIGH volume setting.

Illumination:

You can choose whether to shut off the light in the oven automatically or manually (YES/NO selection).

Water hardness:

You can select VERY SOFT, AVERAGE or VERY HARD, depending on the hardness of the water that you are filling the water jug with.

Start the cleaning cycle:

COOKING CHAMBER- will start the cleaning process for the oven cavity.

BOILER DESCALING- will start the limescale removal process from the steam boiler.

Reset settings:

You can restore all settings (language, time and programme) to their default settings. To do this you will need to press the confirmation button **(8)** twice.

Locking the keypad

- If you have switched on the automatic lock setting through the menu, then the keypad will lock after it has been inactive for one minute.

- If you want to lock the keypad manually, then you should press the minus button of the oven function thermostat buttons **(1)** and the plus button of the timer/language selection buttons **(4)** simultaneously.
- If the oven is switched on, then the display will briefly show KEYPAD LOCK ACTIVATED before returning the display to the information it was showing before.
- If the oven is switched off, then a π symbol will appear on the display.
- If an adjustment is attempted whilst the keypad is locked, then the π symbol or the message UNLOCK KEYS will show on the display.
- To release the lock, press the minus button of the oven function thermostat buttons **(1)** and the plus button of the timer/language selection buttons **(4)** simultaneously. The display will show KEYPAD LOCK DEACTIVATED to confirm that the keypad lock has been switched off.

The oven light

- You can choose whether the oven light shuts off automatically or if this has to be done manually, through the SETTINGS menu.
- Switch the oven light on using the oven light ON/OFF button **(5)**. In automatic mode, the oven light will switch off after 5 minutes. In manual mode, you will need to turn the light off manually, using the oven light ON/OFF button **(5)**.

Cleaning and maintenance



Cleaning operations must only be carried out when the oven is cool.

The appliance should be disconnected from your mains supply before commencing any cleaning process.

- The oven should be thoroughly cleaned before it is operated for the first time and after each use. This will avoid residual food stuffs becoming baked on the oven cavity. After residues have been baked on several times, they are far more difficult to remove.

- The oven cavity should only be cleaned using a damp soft cloth or damp non-abrasive sponge. No abrasive cleaners should be used. You should only clean the cavity after the cooking chamber cleaning cycle has been completed (see next page).
- Any stains that may appear on the bottom of the oven will have originated from food splashes or spilt food, these splashes occur during the cooking process. These could possibly be a result of the food being cooked at an excessively high temperature or being placed in cookware that is too small.
- You should make sure that the cooking temperature that is selected is appropriate for the food that you are cooking. You should also ensure that the food is placed in an adequately sized dish and use the drip trays where appropriate.
- Outer parts of the oven should only be cleaned with warm soapy water, using either a sponge or soft cloth. No abrasive cleaners should be used.
- If you use any form of oven cleaner on your appliance, then you must check with the manufacturer of the cleaner that it is suitable for use on your appliance.
- ***Any damage that is caused to the appliance by a cleaning product will not be fixed by Baumatic free of charge, even if the appliance is within the guarantee period.***

Oven cavity cleaning cycle

The purpose of this feature is to facilitate the removal of food and grease from the oven cavity after cooking.

- Fill the water jug with distilled water, or if this is unavailable cold drinking water.
- Fill the water jug up to the 1.2 litre mark. DO NOT fill the jug right to the top. Otherwise the water that is pumped back into the jug at the end of the cleaning cycle may overflow.
- Insert the jug into the water jug compartment.
- Push the jug down completely, this ensures a perfect seal between the tube located in the jug and the hydraulic circuit inside of the oven.
- Switch the oven on using the oven ON/OFF button **(6)**. ← →
SELECT COOKING ↓ MENU will appear on the display.

- Use the oven setting selection buttons **(9)** until SETTINGS appears on the display. Press the confirmation button **(8)** to confirm your choice.
- Use the oven setting selection buttons **(9)** until START THE CLEANING CYCLE appears on the display. Press the confirmation button **(8)** to confirm your choice.
- Use the oven setting selection buttons **(9)** until COOKING CHAMBER appears on the display. Press the confirmation button **(8)** to confirm your choice.
- Follow the instructions that appear on the display. The cavity will be filled with a quantity of steam for approximately 10 minutes.
- When the cleaning cycle is finished, use a damp soft cloth or damp non-abrasive sponge to wipe over the cavity of the oven.

Boiler descaling

The purpose of this feature is to remove any limescale that may have built up in the steam boiler.

- **IMPORTANT:** *We recommend that you use distilled water in the water jug, this will minimise the chances of limescale building in the first place.*
- If you do use your household water supply to fill the water jug with, then over a period of time, limescale will start to build in the steam boiler.
- Eventually if limescale builds to a particular level, when you switch on the oven, the message DESCALING CYCLE RECOMMENDED FOR BOILER will appear on the display.
- The boiler descaling cycle has a fixed duration of 12 hours, therefore we suggest that you run it overnight.
- Fill the water jug up to the 1.2 litre mark. DO NOT fill the jug right to the top. Otherwise the water that is pumped back into the jug at the end of a cooking cycle may overflow.
- Add 5 teaspoons of citric acid monohydrate (available from a pharmacy) to the water jug and stir it until it dissolves.
- **IMPORTANT:** *Do not use vinegar or any vinegar based products to descale the boiler.*
- Insert the water jug into the water jug compartment.

- Push the water jug down completely, this ensures a perfect seal between the tube located in the jug and the hydraulic circuit inside of the oven.
- Switch the oven on using the oven ON/OFF button **(6)**. ← →
SELECT COOKING ↓↓ MENU will appear on the display.
- Use the oven setting selection buttons **(9)** until SETTINGS appears on the display. Press the confirmation button **(8)** to confirm your choice.
- Use the oven setting selection buttons **(9)** until BOILER DESCALING appears on the display. Press the confirmation button **(8)** to confirm your choice.
- The display will show how long remains until the end of the descaling process.
- When the descaling process is complete, a boiler wash and rinsing process will need to be followed (see next page).

Boiler wash

IMPORTANT: After completing boiler descaling, this process **MUST** be followed. You should switch off the appliance at your mains supply before attempting the following procedure.

- After boiler has been descaled, dirty water will be emptied into the water jug.
- ***YOU MUST*** empty the water jug, then rinse it out and fill it with clean water. This should be done several times to make sure that there is no residue left inside of the water jug.
- If water drips from the filter container, you should unscrew the cap, filter and gaskets from it. Dry all of these parts and the filter container thoroughly with a cloth or small sponge, before replacing them.

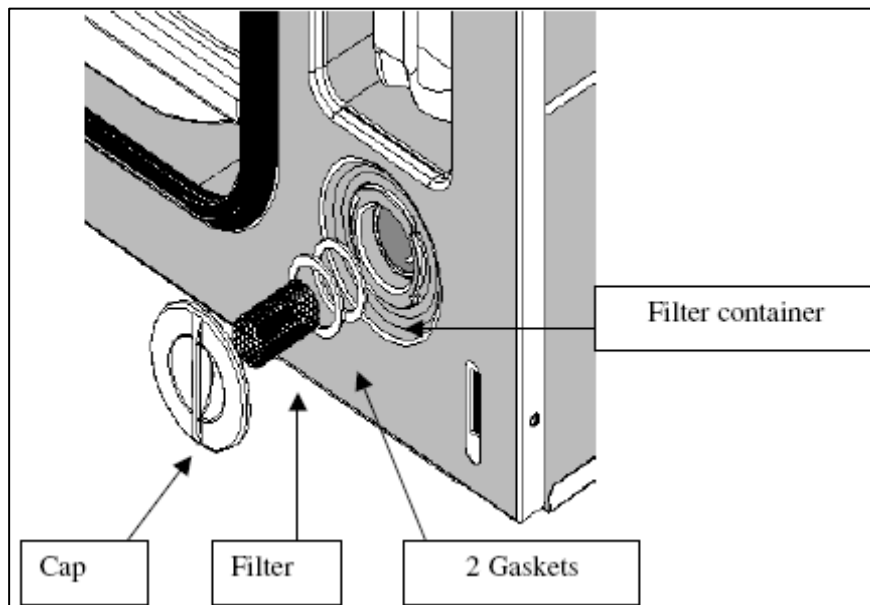

- **IMPORTANT:** YOU MUST replace the two white gaskets when reinserting the filter, ensuring that they are in the position shown in the above diagram. You should also make sure that the cap is turned until it is fully tightened inside of the filter container.

Removing the side racks

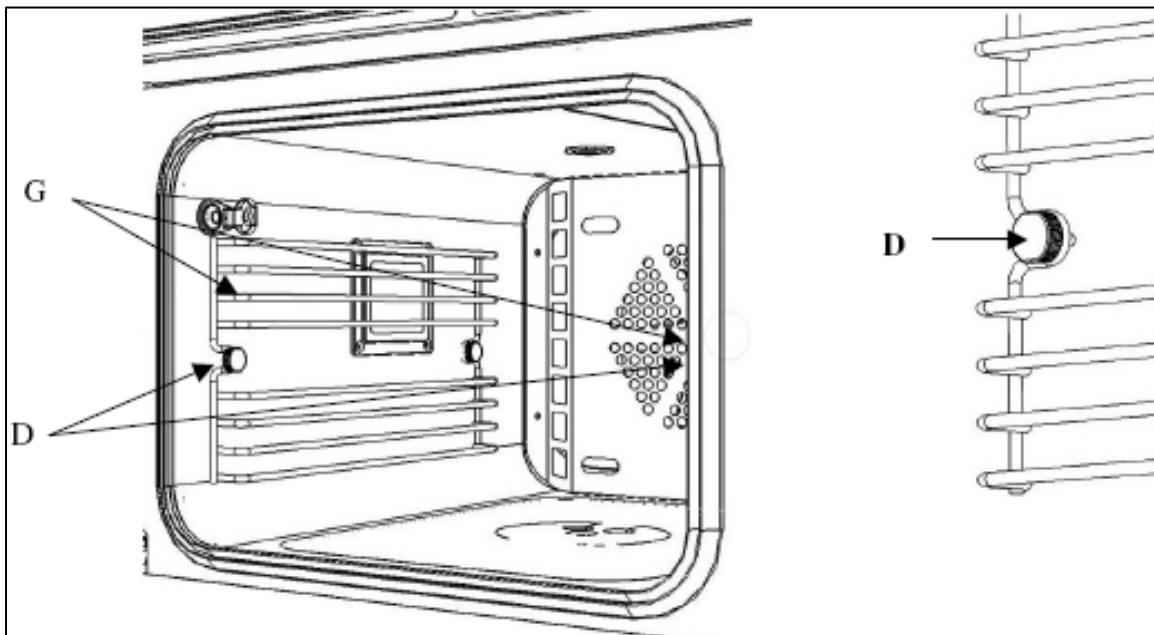

- Turn the front nut (**D**) anticlockwise and remove it from the oven cavity.
- Remove the side racks (**G**) one at a time by pulling them away from the oven cavity.
- To replace the side racks, insert them back into the oven cavity.

- **IMPORTANT:** The indent on one end of the side racks, must be positioned at the front of the oven cavity (as shown in the above picture).
- Fully retighten the front nuts **(D)**.

Replacing the oven bulb



IMPORTANT: The oven must be disconnected from your mains supply before you attempt to either remove or replace the oven bulb.

- Remove all oven shelves, drip trays and the side rack that is on the same side as the oven light.

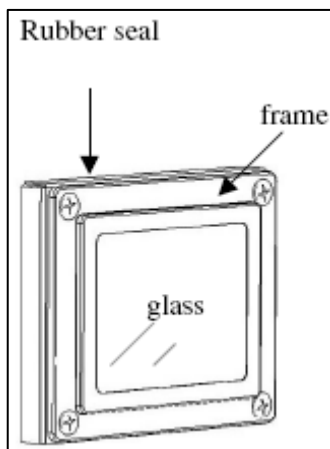

- Remove the light cover by removing the 4 screws located in the corners of the glass cover.
- Place the glass cover gently on a supported surface, so that damage is not caused to it whilst the bulb is being replaced.

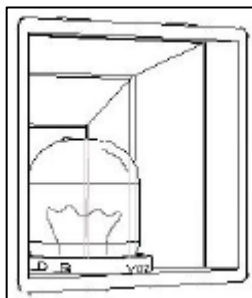

- Unscrew the bulb and remove it from its holder.
- Replace the bulb with a 25 W/300°C, E14 screw type pigmy.
- **Do not** use any other type of bulb.

- Place the lamp cover back into position and fully tighten the 4 screws that were removed previously.
- Replace the side rack, drip trays and oven shelves.
- Restore power to the appliance.

Removing the oven door for cleaning

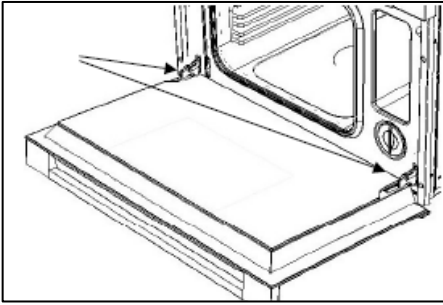

- Fully open the oven door.
- Locate the oven door hinges (see drawing above).

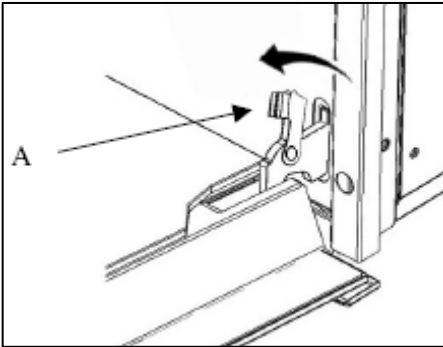

- Tip back the brackets **(A)** on both of the hinges.

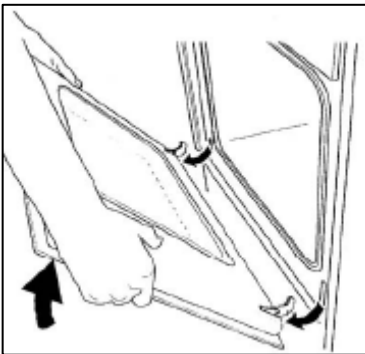

- You should grip the sides of the door at the centre and then incline it slightly towards the oven cavity. By pulling the lower part of the oven door away from the oven, the hinges will disengage from the holes that they are located in.

- **IMPORTANT:** You should make sure that the door is supported at all times and that you place the door on some padded material whilst cleaning it.
- The oven door and door glass should only be cleaned using a damp cloth and a small amount of detergent. The cloth **MUST NOT** have come into contact with any form of cleaning product or chemical previously.

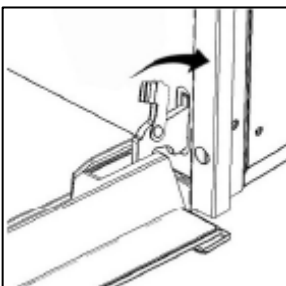

- To refit the door you should slide the hinges back into their slots and open the door fully.
- **IMPORTANT:** The brackets **(A)** must be closed back into their original positions before closing the door.



- **Take care not to dislodge the hinge locking system when removing the door, as the hinge mechanism has a strong spring.**
- **Do not immerse the door in water at any time.**

INSTALLATION



The installation must be carried out by a suitably qualified person, in accordance with the current version of the following.

- UK Regulations and Safety Standards or their European Norm Replacements.
- **Building Regulations** (issued by the Department of the Environment).
- **Building Standards** (issued by the Scottish Development Department).
- **IEE Wiring Regulations.**
- **Electricity At Work Regulations.**

Before connecting the appliance, make sure that the supply voltage marked on the Rating Plate corresponds with your mains supply voltage.

WARNING: THIS APPLIANCE MUST BE EARTHED.

- This appliance should be wired into a 13 A double pole switched fused spur outlet, having 3 mm contact separation and placed in an easily accessible position adjacent to the appliance. The spur outlet must still be accessible even when your oven is located in its housing.

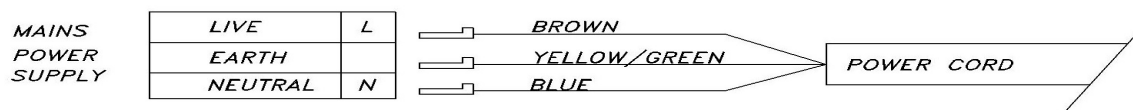

- To connect the oven power cord, loosen and remove the cover on the terminal block, in order to gain access to the contacts inside. Make the connection, securing the cord in place with the cable clamp provided and then immediately close the terminal block cover again.

- If you have to change the oven power cord, the earthing (yellow/green) conductor must always be 10 mm longer than the line conductors.
- Care must be taken to ensure that the temperature of the mains supply cable does not exceed 50°C.
- If the mains supply cable is damaged, then it must be replaced by an appropriate replacement which can be obtained from the Baumatic Spares Department.

Installing the oven into the kitchen cabinet

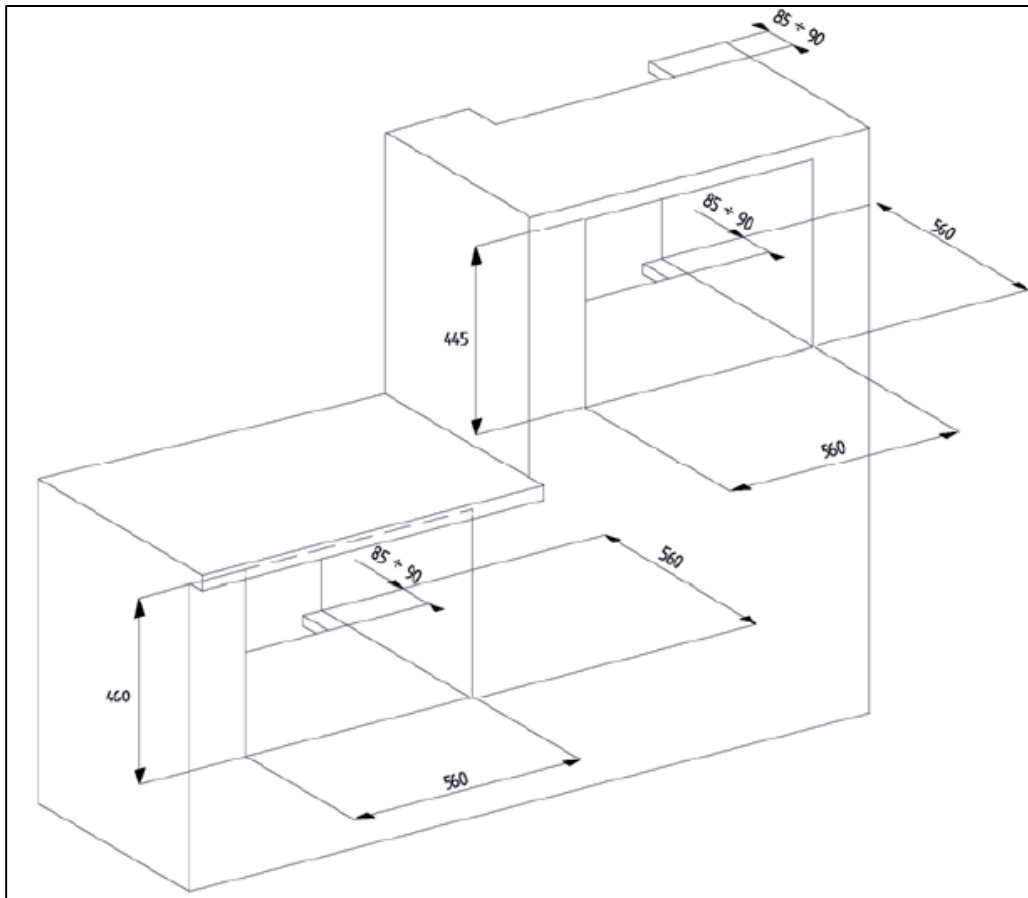

Positioning the appliance

- Ensure that the aperture that you will be fitting the oven into is of the size given in the above diagram.
- The oven must be fitted into an oven housing with the ventilation cut-outs shown in the "Ventilation requirements" section on the next page.
- Ensure that the rear panel of the furniture housing unit has been removed.

- **IMPORTANT:** You must not install the appliance in a location where the ambient temperature will fall below 5°C.

Ventilation requirements

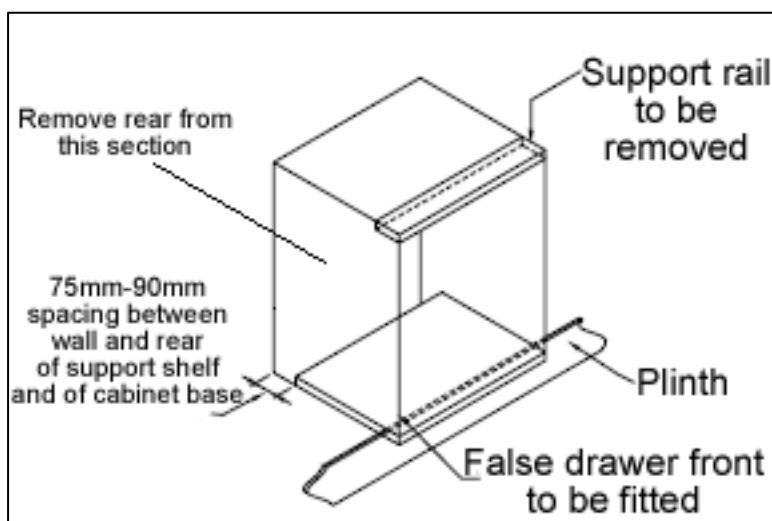

(Figure shows the ventilation and cut-out requirements for the installation of the appliance into a standard kitchen unit).

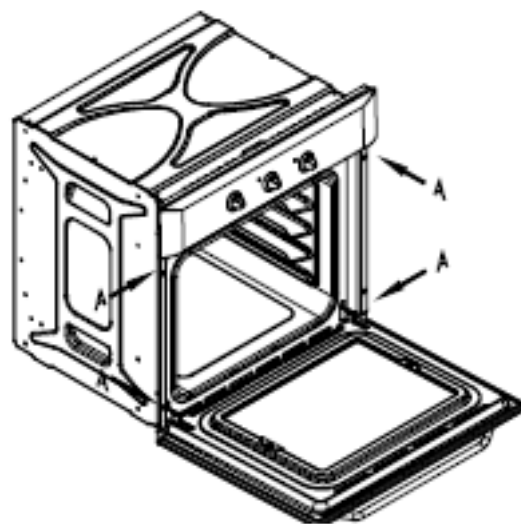
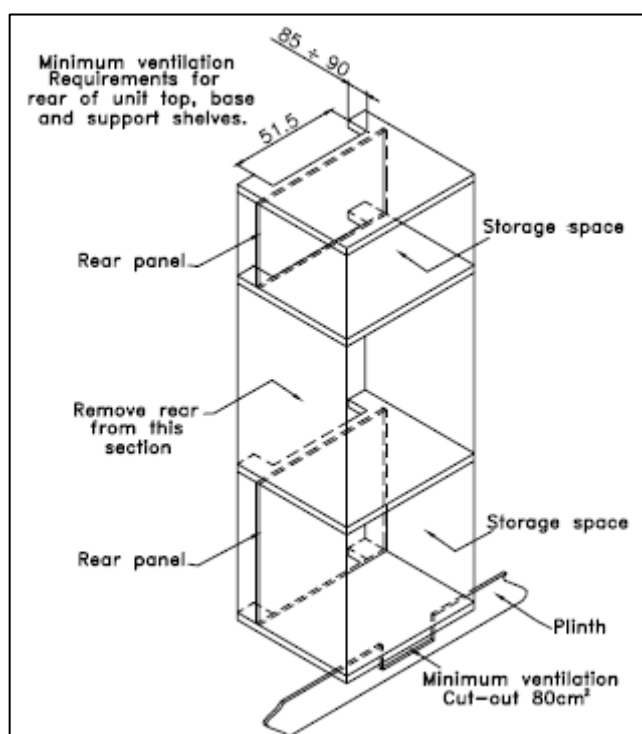

(Figure shows the ventilation and cut-out requirements for the installation of the appliance into a tall housing unit).

- Ensure that the oven has been securely fixed into the housing unit. The fixing of the oven into the housing is made by using four screws. These should be screwed through the oven cabinet and into the housing unit.

My appliance isn't working correctly

Error codes chart

Error code	Cause	Solution
ERR 001	<p>BOILER OVERHEAT This alarm is caused by the fill pump being unable to pump water from the water jug to the boiler.</p> <p>The causes may be:-</p> <ul style="list-style-type: none"> a) empty pitcher b) a leak in the hydraulic circuit c) a broken pump d) an electronic failure in the power circuit. 	<p>Check that there is water in the pitcher. Turn the oven off and then on again. If the failure occurs again, make a note of the error code and then contact the Baumatic Service Department, advising them of this code.</p>
ERR 002	BOILER PROTECTION ALARM	<p>Make a note of the error code and then contact the Baumatic Service Department, advising them of this code.</p>
ERR 003	POWER CARD OVERHEAT	<p>Check whether the ventilation requirements in the installation instructions have been followed.</p> <p>Make a note of the error code and then contact the Baumatic Service Department, advising them of this code.</p>
ERR 004	PT1000 oven cavity sensor fault	<p>Make a note of the error code and then contact the Baumatic Service Department, advising them of this code.</p>
ERR 005	Food sensor fault	<p>Make a note of the error code and then contact the Baumatic Service Department, advising them of this code.</p>
ERR 006	Boiler thermocouple fault	<p>Make a note of the error code and then contact the Baumatic Service Department, advising them of this code.</p>
ERR 007	Oven cavity steam presence thermocouple fault	<p>Make a note of the error code and then contact the Baumatic Service Department, advising them of this code.</p>
ERR 008	Oven cavity overheating	<p>Make a note of the error code and then contact the Baumatic Service Department, advising them of this code.</p>
ERR 009	NTC sensor fault	<p>Make a note of the error code and then contact the Baumatic Service Department, advising them of this code.</p>

- ***The oven isn't coming on.***
 - * Check that you have selected a cooking function and a cooking temperature.
- ***There appears to be no power to the oven.***
 - * Check that the appliance has been connected to the electrical mains supply correctly.
 - * Check that the mains fuses are in working order.
 - * Check that the operating instructions for setting the time of day have been followed.
- ***The oven light is not working***
 - * Refer to the "Replacing the oven bulb" section.
- ***The display shows ERR and a number***
 - * The appliance has generated an error code, see page 42 for more information on error codes and what they mean.
- ***Water takes a long time to drain from the boiler after you have finished cooking***
 - * For reasons of safety, the boiler will not drain until the temperature of the water has dropped below 90°C. It is perfectly normal for there to be a delay between the end of the cooking process and the water being pumped out. It is possible to start another cooking process during this time.
- ***Steam comes out of the oven during operation***
 - * Check that the oven door is completely shut.
 - * Check whether the oven door seal is damaged or cracked. If it is, then contact the Baumatic Service Department.
- ***What happens if power is cut to the appliance***
 - * It may be necessary to set the time of day again.
 - * The stored settings and recipes would not be lost.
 - * If the power cut occurred whilst the oven was cooking, then you will need to reselect the cooking function and temperature.

- * If you were descaling the boiler when the power cut occurred, you will need to drain the citric acid monohydrate solution contained in the boiler. See the section entitled "Boiler wash" on page 35.



IMPORTANT: If your appliance appears not to be operating correctly, then you should disconnect it from your mains supply and then contact the Baumatic Service Department on telephone number (0118) 933 6911.

DO NOT ATTEMPT TO REPAIR THE APPLIANCE YOURSELF.

Please note that if an engineer is asked to attend whilst the product is under guarantee and finds that the problem is not the result of an appliance fault, then you may be liable for the cost of the call out charge.

The appliance must be accessible for the engineer to perform any necessary repair. If your appliance is installed in such a way that an engineer is concerned that damage will be caused to the appliance or your kitchen, then he will not complete a repair.

This includes situations where appliances have been tiled in, sealed in with sealant, have wooden obstructions placed in front of the appliance, like plinths. Or any installation other than the one specified by Baumatic Ltd. has been completed.

Please refer to the conditions of guarantee that appear on the warranty card that you receive with the appliance.

**United Kingdom**

Baumatic Ltd.,
Baumatic Buildings,
6 Bennet Road,
Reading, Berkshire
RG2 0QX
United Kingdom

Sales Telephone

(0118) 933 6900

Sales Fax

(0118) 931 0035

Customer Care Telephone

(0118) 933 6911

Customer Care Fax

(0118) 986 9124

Spares Telephone

(01235) 437244

Advice Line Telephone

(0118) 933 6933

E-mail:

sales@baumatic.co.uk
customercare@baumatic.co.uk
spares@baumatic.co.uk
technical@baumatic.co.uk

Website:

www.baumatic.co.uk

Republic of Ireland**Service Telephone**

1-890 812 724

Spares Telephone

091 756 771

Czech Republic

Baumatic CR spol s.r.o.
Průmyslová zóna Sever 696
460 11 Liberec 11
Czech Republic

+420 483 577 200

www.baumatic.cz

Slovakia

Baumatic Slovakia, s.r.o.
Galvániho 7/D
Slovakia

+421 255 640 618

Germany

Baumatic Gmbh
Lilienthalstrasse 1
320 52 Herford
Deutschland

+49 5221 694 99-0

www.baumatic.de

Italy

Baumatic Italia S.R.L.
Via Galvani N.3
35011 Campodarsego (PD)

+3904 9920 2297

www.baumatic.it

Holland

Baumatic Benelux B.V.
Grindzuigerstraat 22
1333 MS ALMERE
Nederland

+3136 549 1555

www.baumatic.nl

