

**BHI631SS 60cm Front  
touch control  
induction zone hob**

**INSTRUCTION MANUAL**

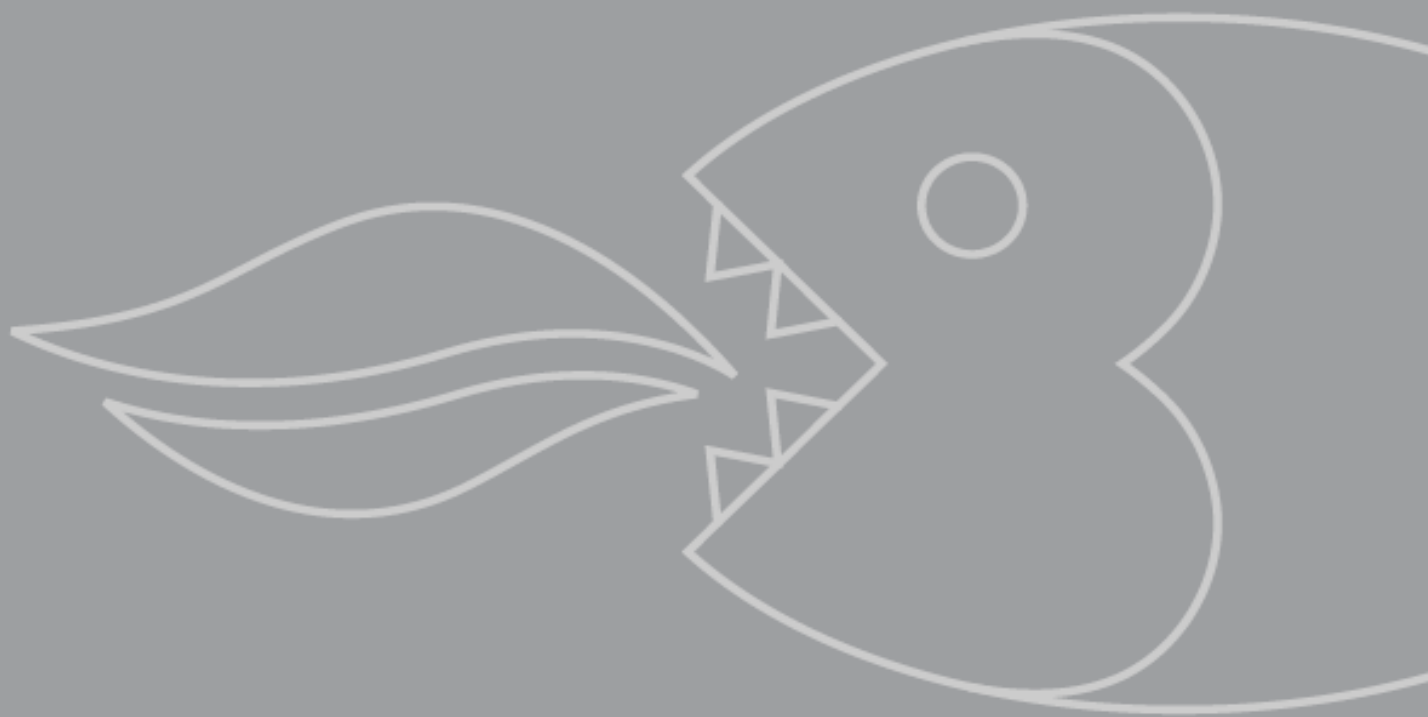

# User Manual for your Baumatic

## **BHI631SS**

**60 cm Touch control  
induction zone hob**



***NOTE: This User Instruction Manual contains important information, including safety & installation points, which will enable you to get the most out of your appliance. Please keep it in a safe place so that it is easily available for future reference; for you or any person not familiar with the operation of the appliance.***

# Contents

<b>Environmental note</b>	4
<b>Important safety information</b>	5 – 8
<b>Specifications</b>	9 – 11
Dimensions	9
Electrical details	10
Ceramic hob surface layout	10
Control panel layout	11
<b>Using the ceramic hob</b>	11 - 18
Before first use	11
Touch controls	11
Switching the hob on	12
Switching on a zone and setting a power level	12
Switching off a zone gradually	12
Switching off a zone instantly	12 - 13
Switching the hob off	13
Residual heat indicator	13
Pan sensor	13 - 14
Cookware that is suitable for an induction hob	14
The hob timer	14 - 15
The safety lock	15
Safety cut-off	16
Recall function	16
Fan control	16 - 17
Hob guidelines	17 - 18
<b>Cleaning and maintenance</b>	18 - 19
Cleaning the ceramic hob top	18
After each use	18
Cleaning table	19
Using a ceramic hob scraper	19
Using a specialist ceramic hob cleaner	19
<b>Installation</b>	20 - 25
Positioning	20 - 21
Unpacking the appliance	21
Installing the appliance	21- 23
Electrical connection	24
Connecting the mains supply cable	24- 25
Replacing the mains supply cable	25
<b>My appliance isn't working correctly</b>	26 - 28
Error codes	27
<b>Contact details</b>	29

## Environmental note

**This appliance is marked according to the European directive 2002/96/EC on Waste electrical and Electronic Equipment (WEEE). By ensuring this product is disposed of correctly, you will help prevent potential negative consequences for the environment and human health, which could otherwise be caused by inappropriate waste handling of this product.**

The symbol  on the product, or on the documents accompanying the product, indicates that this appliance may not be treated as household waste. Instead it shall be handed over to the applicable collection point for the recycling of electrical and electronic equipment.

**Disposal must be carried out in accordance with local environmental regulations for waste disposal.**

**For more detailed information about treatment, recovery and recycling of this product, please contact your local city office, your household waste disposal service or the shop where you purchased the product.**



- The packaging materials that Baumatic uses are environmentally friendly and can be recycled.
- Please discard all packaging material with due regard for the environment.

## Important safety information



Your safety is of the utmost importance to Baumatic. Please make sure that you read this instruction booklet **before** attempting to install or use the appliance. If you are unsure of any of the information contained in this booklet, please contact the Baumatic Advice Line.

### General Information

- This appliance is designed for domestic household use and for the cooking and frying of domestic foodstuffs.
- **IMPORTANT:** *The adjacent furniture and all materials used in the installation **must** be able to withstand a minimum temperature of 85°C above the ambient temperature of the room it is located in, whilst in use.*
- Certain types of vinyl or laminate kitchen furniture are particularly prone to heat damage or discolouration at temperatures below the guidelines given above.
- Any damage caused by the appliance being installed in contravention of this temperature limit, **will be the liability of the owner.**
- Your new appliance is guaranteed against electrical or mechanical defects, subject to certain exclusions that are noted in Baumatic's Conditions Of Guarantee. The foregoing does not affect your statutory rights.
- The use of this appliance for any other purpose or in any other environment without the express agreement of Baumatic Ltd. will invalidate any warranty or liability claim.
- You should not use this appliance to store items on or as a work surface.
- No modifications to the appliance are permitted by Baumatic Ltd.
- You should not store or place flammable or highly flammable liquids/materials on top of or near the appliance. Items made from aluminium, plastic or plastic film should also be kept away from the appliance, as they may fuse to the surface.
- **Repairs may only be carried out by Baumatic service engineers or their authorised service agent.**

## Child Safety

- Baumatic strongly recommend that babies and young children are prevented from being near to the appliance and not allowed to touch the appliance **at any time**. During and after use, all surfaces will be hot.
- If it is necessary for younger family members to be in the kitchen, please ensure that they are kept under close supervision at all times.
- Older children should only be allowed to utilise the appliance when supervised.

## General Safety

- The appliance should only be installed and connected by a suitably qualified person.
- Care should be taken to ensure that the units and work surfaces that you build the appliance into, meet with the relevant standards.
- If you notice any scratches, splits or cracks in the ceramic glass, you should immediately switch off the appliance and disconnect it from your mains supply. Otherwise there is the risk of electric shock occurring.

## During use

- Any film or stickers that are present on the hob surface when it is delivered should be removed before use.
- Care should be taken when utilising the appliance, otherwise there is a risk of burns being caused.
- You should not allow the electrical connection cables to come into contact with the hob surface when it is hot or any hot cookware.
- If fat and oil overheats, then it can ignite extremely quickly. For this reason, when cooking with fat and oil the appliance should not be left unattended.
- Make sure that all of the cooking zones are switched off after use.

- **IMPORTANT:** *This ceramic induction hob fully complies with current legislation regarding electro-magnetic interference and is designed not to interfere with other electronic appliances providing these comply with the same legislation.*
- *As the hob generates magnetic fields in its immediate vicinity, pacemakers and active heart implants must be designed to comply with relevant regulations. If in doubt, you should consult the manufacturer of your device or your doctor. In this respect, Baumatic can only guarantee the conformity of our own product.*
- *If an object made of metal, (e.g. saucepan lid, knife, fork or spoon) is placed on a cooking zone that is switched on, it can get hot.*

## **Cleaning**

- Cleaning of the hob should be carried out on a regular basis.
- **IMPORTANT:** *Before attempting to clean the appliance, it should be disconnected from the mains and allowed to cool.*
- Great care should be taken whilst using this appliance and when following the cleaning procedure.
- You should not use a steam jet or any other high pressure cleaning equipment to clean the appliance.

## **Installation**



***This appliance must be correctly installed by a suitably qualified person, strictly in accordance with the manufacturer's instructions. Please see the specific section of this booklet that refers to installation.***

***Baumatic Ltd. declines any responsibility for injury or damage, to person or property, as a result of improper use or incorrect installation of this appliance.***

## **Declaration of conformity**

This appliance complies with the following European Directives:

- 73/23/EEC dated 19/02/1973 Low Voltage Directive.
- 89/336/EEC dated 03/05/1989 EMC Directive inclusive of Amending Directive 92/31/EEC.
- 93/68/EEC dated 22/07/1993 CE Marking Directive.
- 89/109/EEC dated 25/01/1992 Materials that can touch food.

- The manufacturer declares that the hob is built using certified materials and requires the appliance to be installed in accordance with the standards currently in force. This appliance must be used by a trained person for domestic purposes only.

## **To avoid damaging your appliance**

- The ceramic glass can be damaged by objects falling onto it.
- The ceramic glass edge can be damaged by knocks from cookware.
- Cast iron and cast aluminium cookware with damaged bases may scratch the ceramic surface if they are dragged across it.
- Pans should be lifted on and off the hob surface and not dragged.
- Cooking zones should not be switched on without cookware placed on it. Also the cookware should not be empty.
- Food or liquid that has high sugar content may damage the hob top, if it comes into contact with the ceramic hob surface. Any spillages should be wiped up immediately, however this may not prevent the hob surface from becoming damaged.



## Specifications

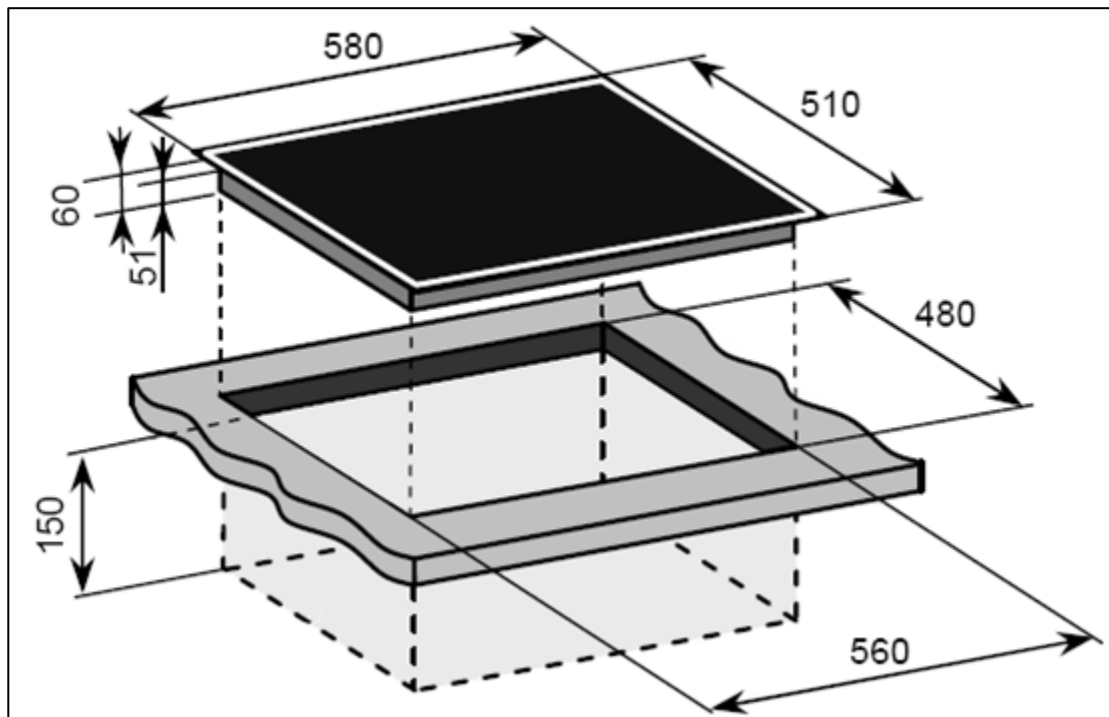

### Product dimensions:

Depth: 510 mm  
Width: 580 mm  
Height: 60 mm

### Aperture dimensions:

Depth: 480 mm  
Width: 560 mm  
Height: 150 mm

### Product specifications:

- 2 x 2.30 kW induction zone (Ø 200 mm)
- 2 x 1.40 kW induction zone (Ø 160 mm)
- Front touch control operation
- Separate timer for each zone
- Integrated pot detection
- 4 independent induction generators
- 4 individual residual heat indicators
- Recall function
- Safety lock

### Standard accessories

- Ceramic hob scraper

### Electrical details

**Rated Voltage:**

220 - 240 Vac 50 - 60 Hz

**Supply Connection:**

35 A (double pole switched fused outlet with 3mm contact gap)

**Max Rated Inputs:**  
**Mains Supply Lead:**

7.40 kW  
3 core x 6 mm<sup>2</sup> (not supplied)

For future reference please record the following information which can be found on the rating plate and the date of purchase which can be found on your sales invoice. The rating plate of your hob is located on the underneath of the appliance. Therefore it is a good idea to record this information before you install your appliance.

**Model Number** .....

**Serial Number** .....

**Date of Purchase** .....

**Ceramic hob surface layout**

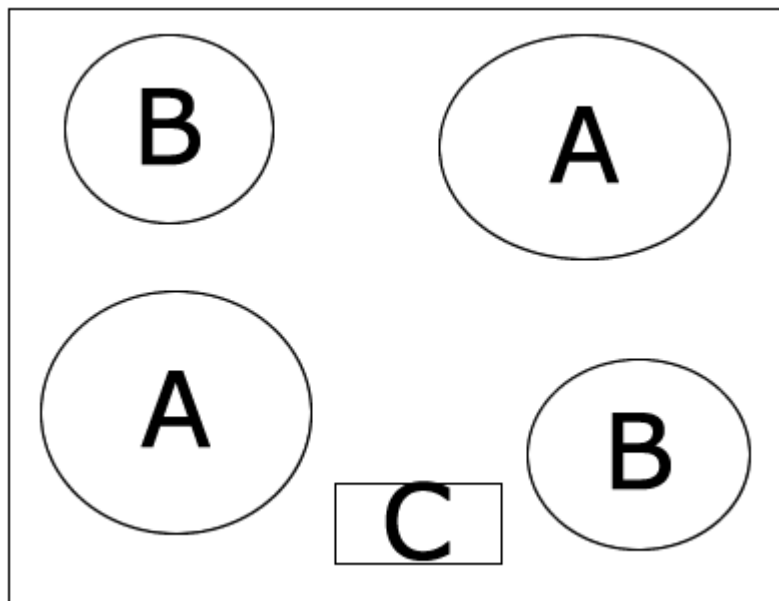

- A)** 2.30 kW induction zone (Ø 200 mm)
- B)** 1.40 kW induction zone (Ø 160 mm)
- C)** Control panel

## Control panel layout

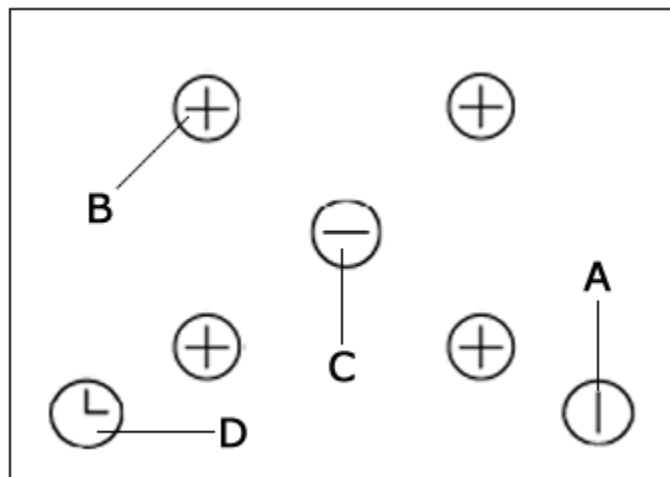

- A) ON / OFF button
- B) Cooking zone plus button
- C) Cooking zone minus button
- D) Timer button

## Using the ceramic hob

### Before first use



**IMPORTANT:** You should clean the ceramic hob surface (see "Cleaning and maintenance" section).

- You should switch on one cooking zone at a time for 5 minutes at the maximum setting. This will help to eliminate any new smell that exists and evaporate any humidity that has formed on the heating elements during transit.
- Do not burn off more than one zone at once.
- **You must** place a saucepan filled half full with cold water on each zone as you burn it off. Otherwise the induction zone will not operate.

### Touch controls

- All operations are performed by means of the touch controls that can be found on the control panel.
- Each touch control has a visual display that corresponds to it.

## Switching the hob on

- When the hob is connected to a power supply all of the cooking zone indicators will come on for 1 second and then go off. The hob has now entered stand-by mode.
- Press the ON/OFF button **(A)**.
- All of the cooking zone indicators will come on.

## Switching on a zone and setting a power level

- Press the cooking zone plus button **(B)** of the cooking zone that you want to use to.
- Select the power level for the cooking zone that you have selected, by using the plus **(B)** and minus **(C)** buttons.
- Starting from level 1, it is increased by one every 0.4 seconds. Upon reaching level 9 you cannot make any further increases.
- When the cooking zone indicator shows the power level that you require, release the plus and minus buttons and the cooking zone will start to heat up the pan.

***IMPORTANT: The cooking zone turns off automatically after a certain time when a cooking level is set but there is no pot placed on it.***

## Switching off a zone gradually

- Press the cooking zone plus button **(B)** of the cooking zone that you want to switch off.
- Press and hold down the minus button **(C)** until the number in the cooking zone indicator reaches "0".
- After a few seconds, the cooking zone will switch off.
- A flashing "H" symbol will show in the cooking zone indicator until the temperature of the zone falls below 60°C (see the section on the "residual heat indicator" for further information).

## Switching off a zone instantly

- Press the zone plus button **(B)** of the cooking zone that you want to switch off.
- Press the plus **(B)** and minus buttons **(C)** simultaneously.

- The zone will switch off immediately.
- A flashing “H” symbol will show in the cooking zone indicator until the temperature of the zone falls below 60°C (see the section on the “residual heat indicator” for further information).

### Switching the hob off

*Once you have switched off all of the cooking zones, you should switch the hob off.*

- Press the ON/OFF button **(A)**.
- It is possible to turn the hob off at any time by pressing the ON/OFF button.

### Residual heat indicator

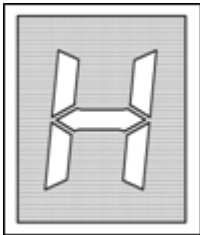

- After a zone is switched off, the corresponding cooking zone indicator will show a flashing letter “H”. This means that the temperature of the zone is over 60°C and is therefore still high enough to cause injury.
- **IMPORTANT:** *The residual heat indicator will disappear if your mains supply is cut.*

### Pan sensor

*Each zone has a sensor on it, so it can detect the presence of a pan.*

- The sensor is fine-tuned to detect a pan being placed on it. The pot detection prevents a cooking zone from turning on without a pot being put on it. The cooking zone turns off as soon as the pot is taken away from it.
- The best heat transfer is obtained when the saucepan and burner are the same size.
- The induction cooking method rapidly transfers the energy needed for cooking directly to the pan, so the cook top surface remains cold but the pan heats up. The result is a fast, cost-effective and accurate cooking method.
- You should check that your pans are suitable for use on an induction zone hob (see the pan manufacturer’s trademark or instructions).

## Cookware that is suitable for an induction hob

The table below shows cookware that is normally suitable for use on an induction zone hob:-

<b>Cookware</b>	<b>Suitable</b>
Steel, enamelled steel	Yes
Cast iron	Yes
Stainless steel	Yes (if stated by the pan manufacturer)
Aluminium, copper, brass	No
Glass, ceramic, porcelain	No

- The bottom of the pans should be as flat and thick as possible.
- Certain types of cookware may result in a noise being made when being used on an induction zone hob. This does not mean that there is an appliance fault.
- **IMPORTANT:** You should make sure that all pans are placed in the centre of the induction zone that you are using.

## The hob timer

Your hob has a timer which, when the programmed period is over, the timed heating element will switch itself off automatically.

- Press the cooking zone plus button **(B)** for the burner you wish to set a timer for. Use the plus and minus buttons to choose a power level for the cooking zone.
- Then press the timer button **(D)** and use the plus and minus buttons to choose a time period of between 1 to 99 minutes.
- When the programmed time is reached, the selected burner will switch off and an alarm will sound. Press any button to deactivate the alarm.
- This timer function can be applied to each burner separately by repeating the steps outlined above after setting the first timer.

**WARNING: It is vital that you do not leave the hob unattended while cooking.**

Your hob also has an alarm mode which is a count-down timer that does not control the heating elements.

- The timer alarm can be activated when the cooking zones are switched off by using the plus and minus buttons.
- You can set a count-down time between 1 – 99 minutes. An alarm will sound when this time is reached. Press any button to deactivate the alarm.
- If you press the power button **(A)** during a count-down duration, the alarm mode goes off automatically.

### **The safety lock**

- The whole hob top can be locked when it is not in use by pressing the cooking zone plus button of the front right burner, then the minus button followed by the cooking zone plus button again.
- All of the zone indicators will display an “L” for locked.
- This procedure must be carried out within 10 seconds and no other keys must be pressed. The hob will remain in the locked state until it is released even if the unit is switched off and on again in the meantime.
- To release the safety lock, press the cooking zone plus button of the front right burner and the minus button simultaneously. The “L” will disappear from the displays.
- After switching off the hob, the child-lock will be reactivated so to turn the safety lock off definitely, press the cooking zone plus button for the front right burner and the minus button simultaneously followed by the minus button again.
- After carrying out all the steps in the correct order and within 10 seconds, the safety lock will be cancelled.

## Safety cut-off

- Based on the power level, each cooking zone is shut off after a maximum preset time if no operations are performed such as a change of power level.
- In principle, the way induction works is intrinsically safe. The induction electronics provide temperature sensors at each cooking zone located below the glass ceramic surface to monitor the temperatures.
- Further temperature sensors along the heat sink protect the electronics against overheating. The software may reduce the power or switch off all cooking zones if a temperature which is too high is measured.
- In addition, when the control panel detects an ambient temperature greater than 95°C it shuts off all the elements. A heating element that is shut off by the thermal protection can only be turned back on when the ambient temperature drops below 95°C.

## Recall function

- The recall function enables settings to be recovered quickly when the control has been switched off by the mains switch by mistake.
- When the control has been switched off, you have 6 seconds to switch it back on again. The execution of this function is only available if at least one cooking zone was active and is confirmed with an acoustic signal.
- If the appliance is switched back on within 6 seconds, it will recall the power level of all cooking zones and the minutes and seconds of all programmed timers.

## Fan control (integrated cooling of the generator)

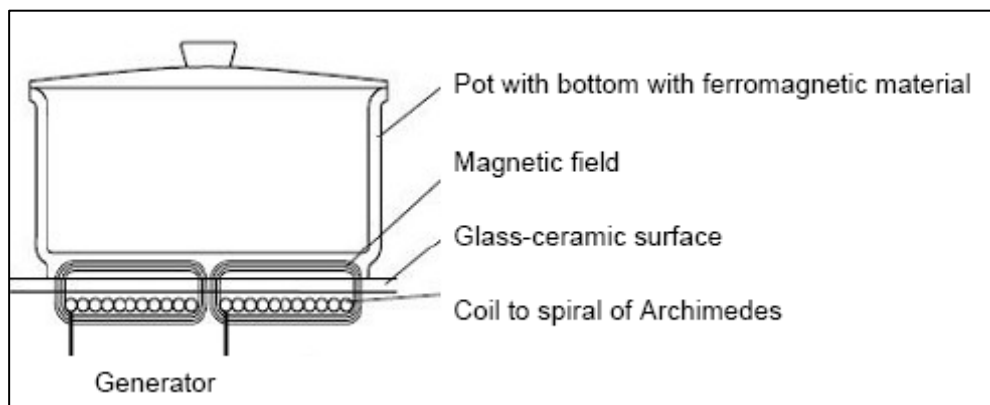



- The cooling of the hob is integrated within the plastic housing of the inductor heat element. The operation of the fan is controlled by the temperature which is measured at the heat sink.
- The fan switches on when a certain temperature is reached and switches to a higher speed when the second temperature limit is reached.
- The lower speed will begin at 45°C and the higher speed will begin at 55°C.

### **Hob guidelines**

- The first few times the hob top is used, it may give off an acrid, burning smell. This smell will disappear completely with repeated use.
- The worktop is fitted with cooking areas of different diameter and power.
- The positions where the heat will radiate from are clearly marked on the hob top. The saucepans must be positioned exactly on these zones for efficient heating to occur. Pans should have the same diameter as the cooking zone that they are being used on.
- You should not use saucepans with rough bottoms, as this can scratch the ceramic surface.
- Before use, make sure that the bottoms of the saucepans are clean and dry.
- When cold, the bottom of the pans should be slightly concave, as they expand when hot and lie flat on the surface of the hob. This will allow the heat to transfer more easily.
- The best thickness for the bottom of the pans is 2 – 3 mm of enamelled steel and 4 – 6 mm for stainless steel with sandwich type bottoms.
- If these rules are not followed, then there will be a great loss of heat and energy. Heat not absorbed by the saucepan, will spread to the hob, frame and surrounding cabinets.
- Preferably cover pans with a lid to permit cooking at a lower heat.
- Always cook vegetables and potatoes, etc. in as little water as possible to reduce cooking times.

- Food or liquid that has high sugar content may damage the hob top if it comes into contact with the ceramic hob surface. Any spillages should be wiped up immediately, however this may not prevent the hob surface from becoming damaged.
- **IMPORTANT:** *The ceramic hob surface is tough; however it is not unbreakable and can be damaged. Especially if pointed or hard objects are allowed to fall on it with some force.*
- **DO NOT USE THE HOB IF THE SURFACE BECOMES BROKEN OR CRACKED. YOU SHOULD CONTACT THE BAUMATIC CUSTOMER CARE DEPARTMENT IMMEDIATELY.**

## Cleaning and maintenance



***Cleaning operations must only be carried out when the hob is cool.***

***The appliance should be disconnected from your mains supply before commencing any cleaning process.***

### Cleaning the ceramic hob top



Any residues that are left on the hob top surface from cleaning agents **will** damage it. You should remove any residues with warm water and a little washing up liquid.



Abrasive cleaners or sharp objects will damage the hob surface; you should clean it using warm water and a little washing up liquid.



Although it is easier to clean some deposits whilst the hob surface is still warm. You should take care not to burn yourself if cleaning the hob surface when it is still warm.

### After each use

- Wipe the appliance over with a damp cloth and a little washing up liquid.
- Dry the appliance by rubbing the surface with a clean cloth.

## Cleaning table

<b><i>Type of deposit</i></b>	<b><i>Remove immediately?</i></b>	<b><i>Remove when the appliance has cooled down?</i></b>	<b><i>What should I use to remove the deposit?</i></b>
Sugar or food/liquid containing sugar	Yes	No	Ceramic hob scraper
Tin foil or plastic	Yes	No	Ceramic hob scraper
Fat splashes	No	Yes	Ceramic hob cleaner
Metallic discolourations	No	Yes	Ceramic hob cleaner
Water splashes or water rings	No	Yes	Ceramic hob cleaner

### Using a ceramic hob scraper

A ceramic hob scraper will be provided with your appliance. The following guidelines should be followed when using the ceramic hob scraper:-

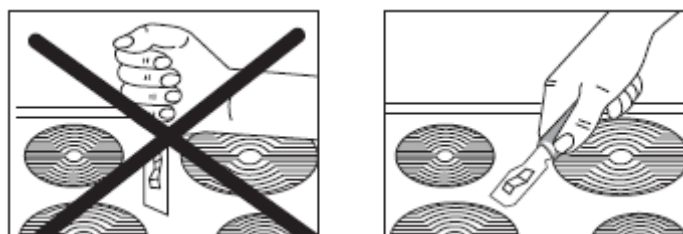

- The scraper should be placed on the ceramic surface at an angle.
- Residues should be removed by sliding the blade carefully over the ceramic surface.
- The ceramic surface should be wiped with a damp cloth and a small amount of washing up liquid.
- Dry the appliance by rubbing the surface with a clean cloth.

### Using a specialist ceramic hob cleaner

It is possible to purchase specialist ceramic hob cleaner/conditioner.

You should follow the instructions given by the manufacturer of the specialist ceramic hob cleaner. You should ensure that it is suitable for use on your appliance.

## Installation



***The installation must be carried out by a suitably qualified person, in accordance with the current version of the following.***

- ***UK Regulations and Safety Standards or their European Norm Replacements.***
- ***Building Regulations*** (issued by the Department of the Environment).
- ***Building Standards*** (issued by the Scottish Development Department).
- ***IEE Wiring Regulations.***
- ***Electricity At Work Regulations.***

### Positioning



***The adjacent furniture must be able to withstand a minimum temperature rise of 85°C above the ambient temperature of the room it is located in, during periods of use.***

This appliance is classified as Class 3 and therefore is to be built into a kitchen unit (depending on size) or 600 mm worktop that is 45 mm thick. The following minimum clearance distances must be observed:-

- 700 mm between the hob surface and the underside of any horizontal surface above it.
- 50 mm clearance around the sides and front of the appliance.
- 55 mm clearance between the back of the hob surface and the wall behind it.
- If the hob is positioned so that the right or left hand side of the appliance will be near to the edge of a kitchen unit. There must be a gap of at least 150 mm between the side of the hob and the vertical surface of the kitchen unit.

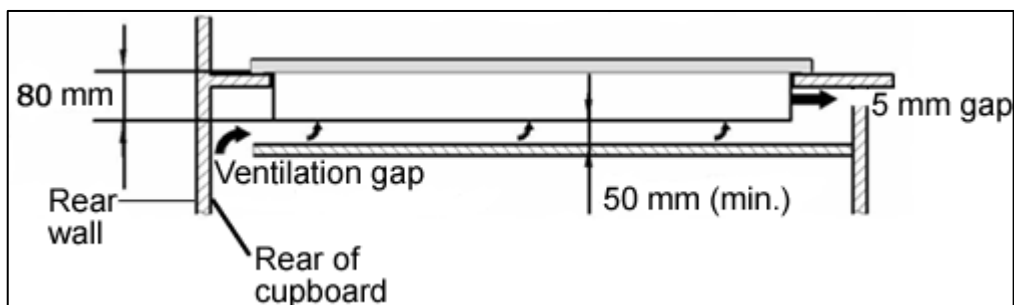

- **IMPORTANT:** Underneath the appliance there must be a partition made of insulating material (e.g. wood). There must be a gap of at least 50 mm between the underneath of the appliance and this partition.
- You must make sure that there is a 5mm gap below the underneath of the worktop at the front edge of the hob.

### Unpacking the appliance

When unpacking the appliance please check that the following items are contained within the packaging:-

- 1 Baumatic hob
- 1 Ceramic hob scraper
- 1 Installation and instruction manual
- 1 Baumatic guarantee card
- 4 Fixing brackets
- 4 Fixing screws

### Installing the appliance

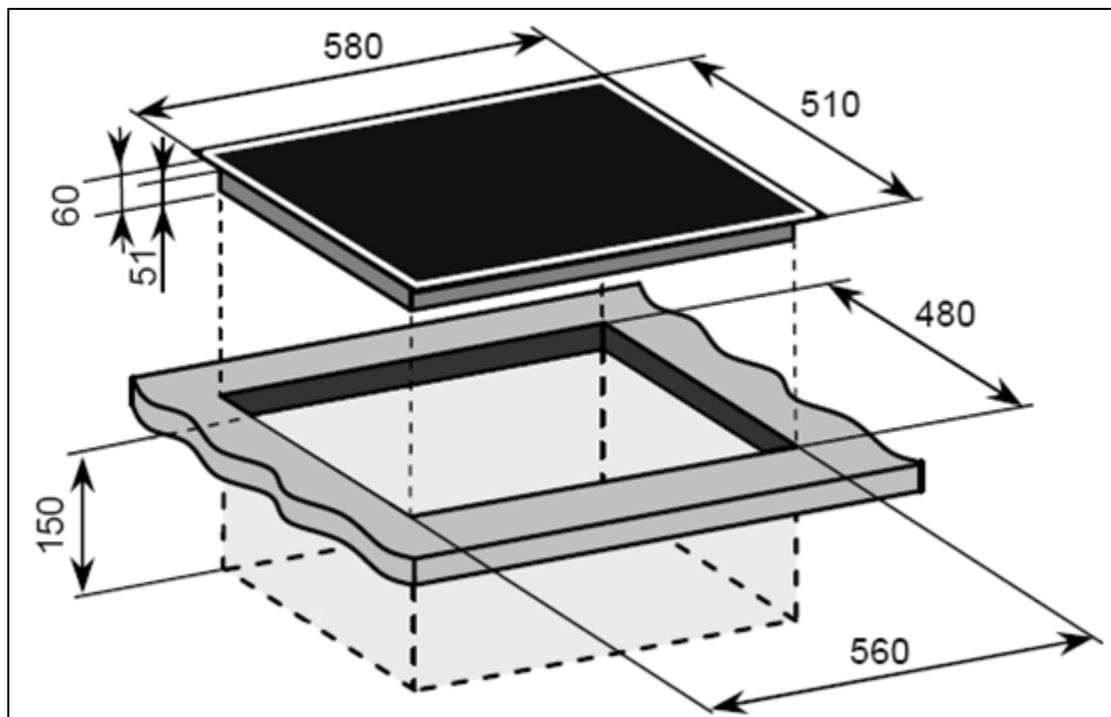

- Cut a hole in the worktop that corresponds with the drawing shown above.
- If the hob is being installed **without** an oven below it, a separator panel must be placed between the bottom of the hob and the housing below it, at a minimum distance of 10 mm.

- If the hob is being installed **with** an oven below it, place a separator panel at a minimum distance of 15 mm and follow the oven manufacturer's instructions, ensuring that sufficient aeration is provided.
- The heat produced by the oven, measured on the right side of the bottom of the hob, must be lower than 60°C, otherwise the heat could damage the touch control panel.
- **IMPORTANT:** You must observe the ventilation requirements shown in the drawing below.

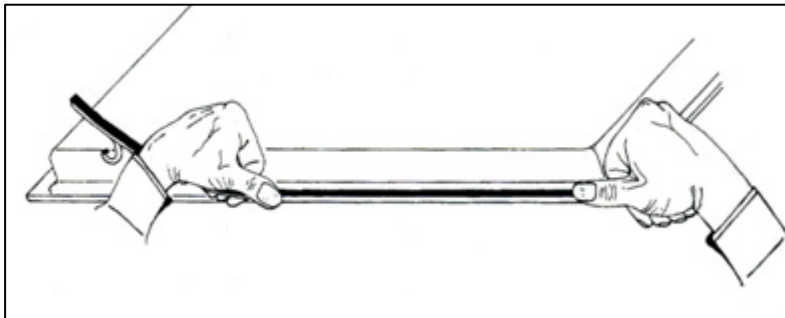
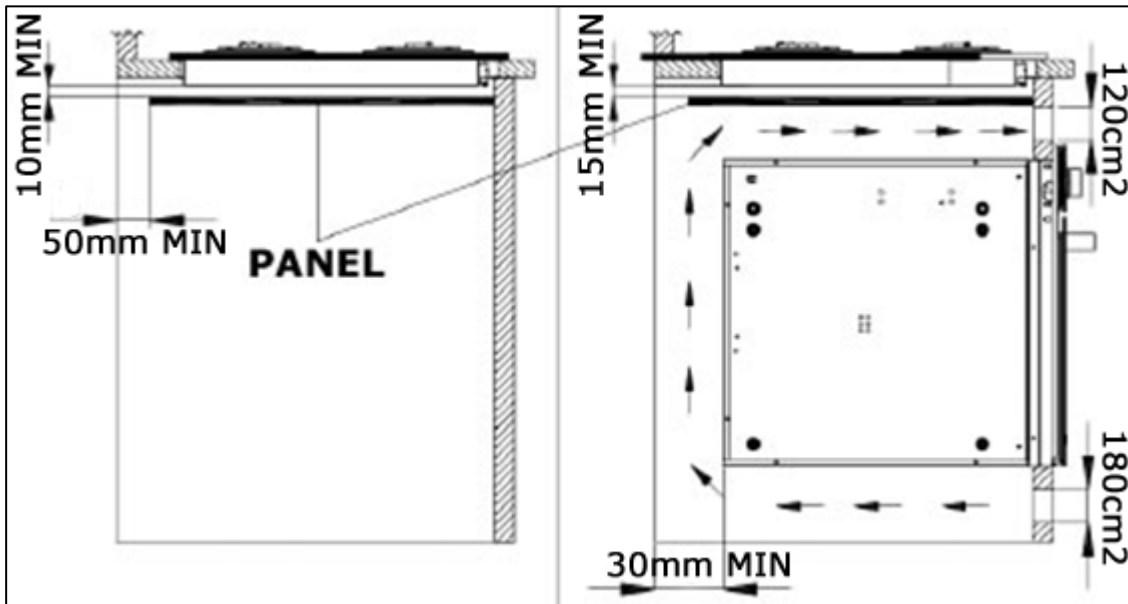

- Carefully turn the hob upside down and place it on a cushioned mat.
- Apply the sealing strip provided **(A)** around the edge of the appliance.
- The protective covering must be removed from both sides.
- Do not leave a gap in the sealing agent or overlap the thickness.

- **IMPORTANT:** Do not use a silicon sealant to seal the appliance against the aperture. This will make it difficult to remove the hob from the aperture in future if it needs to be serviced.

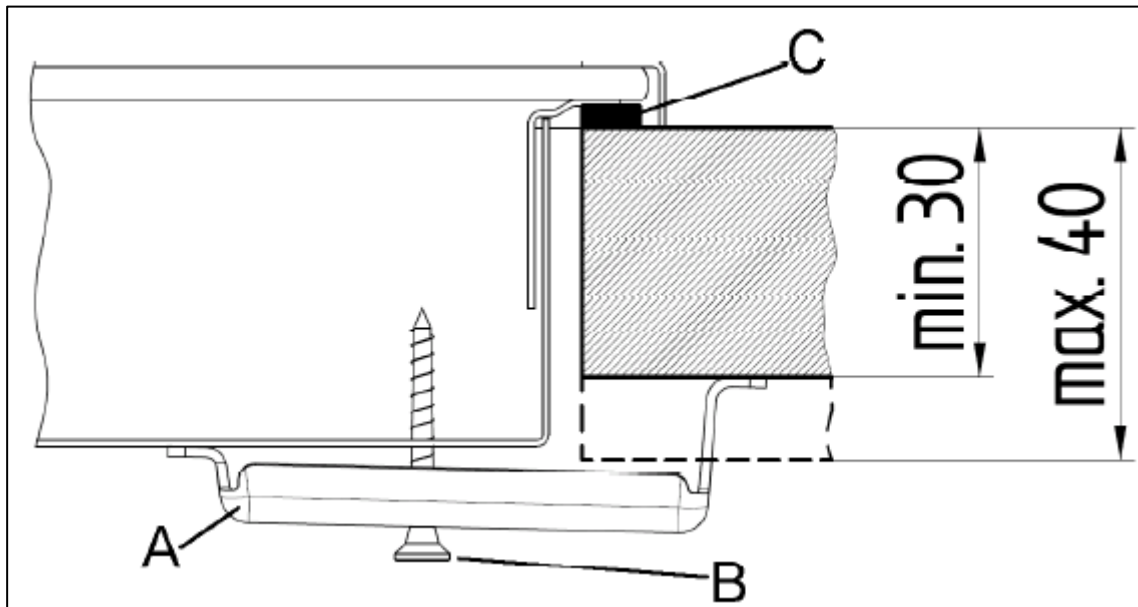

- (A) Sealing strip
- (B) Clamp
- (C) Screw

- Place the clamp **(B)** over the holes that match the size of the screws. There are one set of screw holes in each corner of the hob. Slightly tighten a screw **(C)** through the clamp **(B)** so that the clamp is attached to the hob, but so that you can still adjust the position of it.
- Carefully turn the hob back over and then gently lower it into the aperture hole that you have cut out.
- On the underneath of the hob, adjust the clamps into a position that is suitable for your worktop. Then fully tighten the screws **(C)** to secure the hob into position.

## Electrical connection



***This appliance must be installed by a qualified person in accordance with the latest edition of the I.E.E. Regulations and in compliance with Baumatic's instructions.***

Before connecting the appliance, make sure that the supply voltage marked on the rating plate corresponds with your mains supply voltage.

### **WARNING: THIS APPLIANCE MUST BE EARTHED.**

- This appliance must be wired into a 35 A double pole switched fused spur outlet, having 3 mm contact separation and placed in an easily accessible position adjacent to the appliance. It should not be located above the appliance and no more than 1.25m away from it.
- The spur outlet must still be accessible even when your hob is located in its operating position.
- Cable type: H05 RRF 3 core x 6 mm<sup>2</sup> (not supplied).

### **Connecting the mains supply cable**

- The mains terminal block is located on the underside of the hob and the terminals are accessible by removing the terminal block cover by removing the cover screw.

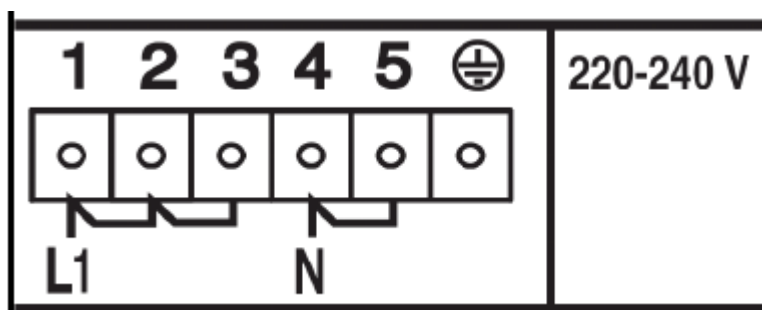

- The brass links must be positioned as marked in the appropriate diagram and once established ALL terminal screws must be tightened down firmly.
- ***If when the hob is first switched on, only two of the zones work, you should recheck that the terminal screws are all fully tightened between the links. This should be done before contacting the Baumatic Customer Care Department.***



- **IMPORTANT:** *The appliance must NOT be connected to the mains supply by means of a 13A plug and socket.*
- The cable can be looped if necessary, but make sure that is not kinked or trapped when the hob is in position. Care must be taken to avoid the cable being in contact with hot parts of the appliance.

### **Replacing the mains supply cable**

If the mains supply cable is damaged, then it must be replaced by an appropriate replacement.

The mains supply cable should be replaced in accordance with the instructions on the next page:

- ***Switch the appliance off at the socket.***
- Open the terminal block on the underside of the hob.
- Unscrew the terminal screws fixing the cable.
- Replace the cable with one of the same length and in accordance with the specification given on page 24.
- The “green-yellow” earth wire must be connected to the terminal marked  $\perp$ . It must be about 10 mm longer than the live and neutral wires.
- The “blue” neutral wire must be connected to the terminal marked with letter (N) - the live wire must be connected to the terminal marked with letter (L).

## My appliance isn't working correctly

- **The cooking zones are not functioning or will not switch on.**
- \* The safety lock has been switched on (see the "Locking the hob top" section for information on how to turn off the safety lock).
- \* Several cooking zone selection buttons have been pressed at once. You should only touch one cooking zone selection button at once.
- \* The safety cut out has been triggered. Press a cooking zone selection button to reset the hob.
- \* Check that the mains electrical supply to the appliance is correct and working. Check the mains fuse.
- \* The pans that you are using are not suitable for use on an induction hob.
- **The residual heat indicator has not come on after I have switched a cooking zone off.**
- \* The cooking zone has only been turned on for a short period of time; therefore it did not go above 60°C.
- \* **IMPORTANT:** *If the cooking zone does appear to be hotter than 60°C and the residual heat indicator has not come on, you should call the Baumatic Customer Care Department.*
- **A humming sound is heard when a cooking zone is selected.**
- \* This is normal; the sound will disappear when the zone heats up.
- **The cooking zones have become discoloured.**
- \* This maybe caused by burnt on remnants of food. This will not affect the working of the appliance. However you should make sure that the cleaning instructions are being followed regularly.
- **Only two of the zones on my hob are working**
- \* You should recheck that the terminal screws are all fully tightened between the links.

## Error codes

The following error codes may appear in the timer display if there is a problem with the operation of the hob.

<b>Error code</b>	<b>Description</b>	<b>Possible cause</b>	<b>Solution</b>
E2	Overheating of the induction coils.	/	Cooling down necessary.
ER03 & permanent tone	Permanent use of keys; control unit cuts off after 10 seconds.	Water or cooking utensils on the glass above the control unit.	Cleaning of the operational surface.
ER25	Secondary voltage of the power unit too high (primary > 300V). Control unit switches off after 1 second and a permanent acoustic signal is heard.	Control wrongly connected.	Connect to correct mains voltage.
ER33	Water on the glass above the control card.		Clean.
ER47	Communication error between TC and induction.	None or faulty communication.	Ensure that connection cable is plugged in correctly.
U400	Secondary voltage of the power unit too high (primary.300V). Control unit cuts off after 1 second releasing a permanent tone.	Control unit is wrongly connected.	Connect to correct mains voltage.
"H" flashes	Hot pan on the control card; faulty radiant hotplate seal.		Wait until the control card returns to the normal temperature.

**IMPORTANT: If any other error codes appear on the cooking zone display, you should turn the appliance off at the mains and contact the Customer Care Helpline. DO NOT continue to use the appliance.**



***IMPORTANT: If your appliance appears not to be operating correctly, then you should disconnect it from your mains supply and then contact Baumatic Customer Care on telephone number (0118) 933 6911.***

***DO NOT ATTEMPT TO REPAIR THE APPLIANCE YOURSELF.***

Please note that if an engineer is asked to attend whilst the product is under guarantee and finds that the problem is not the result of an appliance fault, then you may be liable for the cost of the call out charge.

***The appliance must be accessible for the engineer to perform any necessary repair. If your appliance is installed in such a way that an engineer is concerned that damage will be caused to the appliance or your kitchen, then he will not complete a repair.***

***This includes situations where appliances have been tiled in, sealed in with sealant, have wooden obstructions placed in front of the appliance, like plinths. Or any installation other than the one specified by Baumatic Ltd. has been completed.***

Please refer to the conditions of guarantee that appear on the warranty card that you receive with the appliance.

***IMPORTANT: Baumatic Ltd. operates a policy of continuous improvement and reserves the right to adjust and modify its products without prior notification.***



***United Kingdom***

Baumatic Ltd.,  
Baumatic Buildings,  
6 Bennet Road,  
Reading, Berkshire  
RG2 0QX  
United Kingdom

**Sales Telephone**

(0118) 933 6900

**Sales Fax**

(0118) 931 0035

**Customer Care Telephone**

(0118) 933 6911

**Customer Care Fax**

(0118) 986 9124

**Spares Telephone**

(01235) 437244

**Advice Line Telephone**

(0118) 933 6933

**E-mail:**

sales@baumatic.co.uk  
customercare@baumatic.co.uk  
spares@baumatic.co.uk  
technical@baumatic.co.uk

**Website:**

www.baumatic.co.uk

***Republic of Ireland***

**Service Telephone**

1-890 812 724

**Spares Telephone**

091 756 771

***Czech Republic***

Baumatic CR spol s.r.o.  
Průmyslová zóna Sever 696  
460 11 Liberec 11  
Czech Republic

+420 483 577 200

www.baumatic.cz

***Slovakia***

Baumatic Slovakia, s.r.o.  
Galvániho 7/D  
Slovakia

+421 255 640 618

***Germany***

Baumatic GmbH  
Lilienthalstrasse 1  
320 52 Herford  
Deutschland

+49 5221 694 99-0

www.baumatic.de

***Italy***

Baumatic Italia S.R.L.  
Via Galvani N.3  
35011 Campodarsego (PD)

+3904 9920 2297

www.baumatic.it

***Holland***

Baumatic Benelux B.V.  
Grindzuigerstraat 22  
1333 MS ALMERE  
Nederland

+3136 549 1555

www.baumatic.nl





