

**BHI710 70cm Front
touch control
induction zone hob**

INSTRUCTION MANUAL



User Manual for your Baumatic

BHI710

60 cm Touch control
induction zone hob

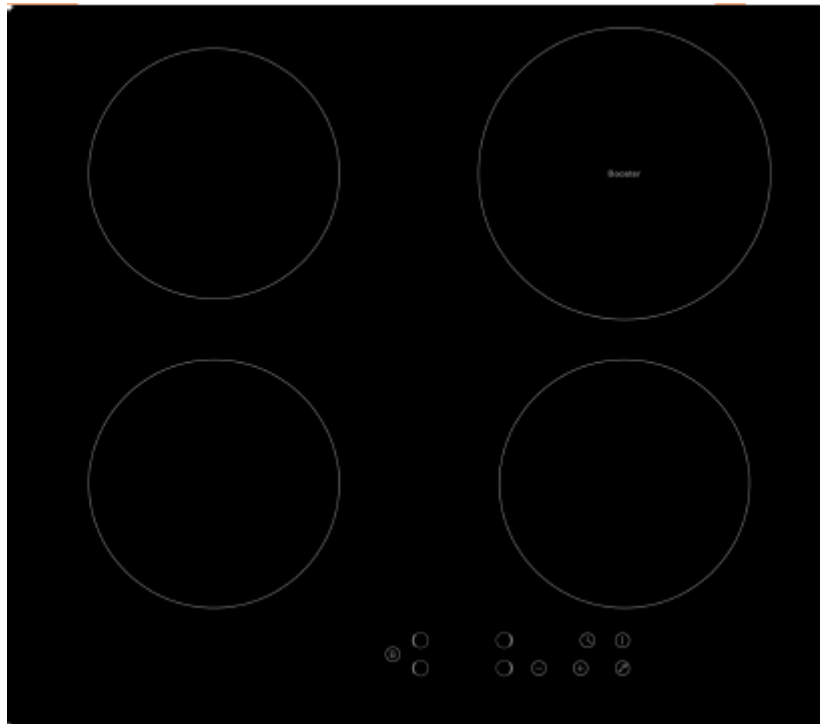

NOTE: This User Instruction Manual contains important information, including safety & installation points, which will enable you to get the most out of your appliance. Please keep it in a safe place so that it is easily available for future reference; for you or any person not familiar with the operation of the appliance.

DD 13/10/10

Contents

Environmental note	4
Important safety information	5 – 8
Specifications	9 - 11
Electrical details	10
Ceramic hob surface layout	10
Control panel layout	11
Using the ceramic hob	11 - 21
Before first use	11
Touch controls	12
Switching the hob on	12
Switching on a cooking zone and setting a power level	12 - 13
Switching off a cooking zone gradually	13
Switching off a cooking zone instantly	14
Switching the hob off	14
Residual heat indicator	15
Booster function	15 - 16
Pan sensor	16
Cookware that is suitable for an induction hob	16 - 17
The hob timer (countdown mode)	17 - 18
The hob timer (linked to a cooking zone mode)	18
Locking the hob top	19
Safety cut-off	19
Hob guidelines	20 - 21
Cleaning and maintenance	21 - 22
Cleaning the ceramic hob top	21
After each use	21
Cleaning table	22
Using a ceramic hob scraper	22
Using a specialist ceramic hob cleaner	22
Installation	23 - 29
Positioning	23 - 24
Installing above a built under oven	24
Unpacking the appliance	24
Installing the appliance	25 - 26
Electrical connection	27
Connecting the mains supply cable	27 - 29
Replacing the mains supply cable	29
My appliance isn't working correctly	30 - 32
Error codes	31 - 32
Contact details	33

Environmental note

This appliance is marked according to the European directive 2002/96/EC on Waste electrical and Electronic Equipment (WEEE). By ensuring this product is disposed of correctly, you will help prevent potential negative consequences for the environment and human health, which could otherwise be caused by inappropriate waste handling of this product.

The symbol  on the product, or on the documents accompanying the product, indicates that this appliance may not be treated as household waste. Instead it shall be handed over to the applicable collection point for the recycling of electrical and electronic equipment.

Disposal must be carried out in accordance with local environmental regulations for waste disposal.

For more detailed information about treatment, recovery and recycling of this product, please contact your local city office, your household waste disposal service or the shop where you purchased the product.



- The packaging materials that Baumatic uses are environmentally friendly and can be recycled.
- Please discard all packaging material with due regard for the environment.

Important safety information



Your safety is of the utmost importance to Baumatic. Please make sure that you read this instruction booklet **before** attempting to install or use the appliance. If you are unsure of any of the information contained in this booklet, please contact the Baumatic Advice Line.

General Information

- This appliance is designed for domestic household use and for the cooking and frying of domestic foodstuffs.
- **IMPORTANT:** *The adjacent furniture and all materials used in the installation **must** be able to withstand a minimum temperature of 85°C above the ambient temperature of the room it is located in, whilst in use.*
- Certain types of vinyl or laminate kitchen furniture are particularly prone to heat damage or discolouration at temperatures below the guidelines given above.
- Any damage caused by the appliance being installed in contravention of this temperature limit, **will be the liability of the owner.**
- Your new appliance is guaranteed against electrical or mechanical defects, subject to certain exclusions that are noted in Baumatic's Conditions Of Guarantee. The foregoing does not affect your statutory rights.
- The use of this appliance for any other purpose or in any other environment without the express agreement of Baumatic Ltd. will invalidate any warranty or liability claim.
- You should not use this appliance to store items on or as a work surface.
- No modifications to the appliance are permitted by Baumatic Ltd.
- You should not store or place flammable or highly flammable liquids/materials on top of or near the appliance. Items made from aluminium, plastic or plastic film should also be kept away from the appliance, as they may fuse to the surface.
- **Repairs may only be carried out by Baumatic service engineers or their authorised service agent.**

Child Safety

- Baumatic strongly recommend that babies and young children are prevented from being near to the appliance and not allowed to touch the appliance **at any time**. During and after use, all surfaces will be hot.
- If it is necessary for younger family members to be in the kitchen, please ensure that they are kept under close supervision at all times.
- Older children should only be allowed to utilise the appliance when supervised.

General Safety

- The appliance should only be installed and connected by a suitably qualified person.
- Care should be taken to ensure that the units and work surfaces that you build the appliance into, meet with the relevant standards.
- If you notice any scratches, splits or cracks in the ceramic glass, you should immediately switch off the appliance and disconnect it from your mains supply. Otherwise there is the risk of electric shock occurring.

During use

- Any film or stickers that are present on the hob surface when it is delivered should be removed before use.
- Care should be taken when utilising the appliance, otherwise there is a risk of burns being caused.
- You should not allow the electrical connection cables to come into contact with the hob surface when it is hot or any hot cookware.
- If fat and oil overheats, then it can ignite extremely quickly. For this reason, when cooking with fat and oil the appliance should not be left unattended.
- Make sure that all of the cooking zones are switched off after use.

- **IMPORTANT:** *This ceramic induction hob fully complies with current legislation regarding electro-magnetic interference and is designed not to interfere with other electronic appliances providing these comply with the same legislation.*
- *As the hob generates magnetic fields in its immediate vicinity, pacemakers and active heart implants must be designed to comply with relevant regulations. If in doubt, you should consult the manufacturer of your device or your doctor. In this respect, Baumatic can only guarantee the conformity of our own product.*
- *If an object made of metal, (e.g. saucepan lid, knife, fork or spoon) is placed on a cooking zone that is switched on, it can get hot.*

Cleaning

- Cleaning of the hob should be carried out on a regular basis.
- **IMPORTANT:** *Before attempting to clean the appliance, it should be disconnected from the mains and allowed to cool.*
- Great care should be taken whilst using this appliance and when following the cleaning procedure.
- You should not use a steam jet or any other high pressure cleaning equipment to clean the appliance.

Installation



This appliance must be correctly installed by a suitably qualified person, strictly in accordance with the manufacturer's instructions. Please see the specific section of this booklet that refers to installation.

Baumatic Ltd. declines any responsibility for injury or damage, to person or property, as a result of improper use or incorrect installation of this appliance.

Declaration of conformity

This appliance complies with the following European Directives:

- 73/23/EEC dated 19/02/1973 Low Voltage Directive.
- 89/336/EEC dated 03/05/1989 EMC Directive inclusive of Amending Directive 92/31/EEC.
- 93/68/EEC dated 22/07/1993 CE Marking Directive.
- 89/109/EEC dated 25/01/1992 Materials that can touch food.

- The manufacturer declares that the hob is built using certified materials and requires the appliance to be installed in accordance with the standards currently in force. This appliance must be used by a trained person for domestic purposes only.

To avoid damaging your appliance

- The ceramic glass can be damaged by objects falling onto it.
- The ceramic glass edge can be damaged by knocks from cookware.
- Cast iron and cast aluminium cookware with damaged bases may scratch the ceramic surface if they are dragged across it.
- Pans should be lifted on and off the hob surface and not dragged.
- Cooking zones should not be switched on without cookware placed on it. Also the cookware should not be empty.
- Food or liquid that has high sugar content may damage the hob top, if it comes into contact with the ceramic hob surface. Any spillages should be wiped up immediately, however this may not prevent the hob surface from becoming damaged.

Specifications

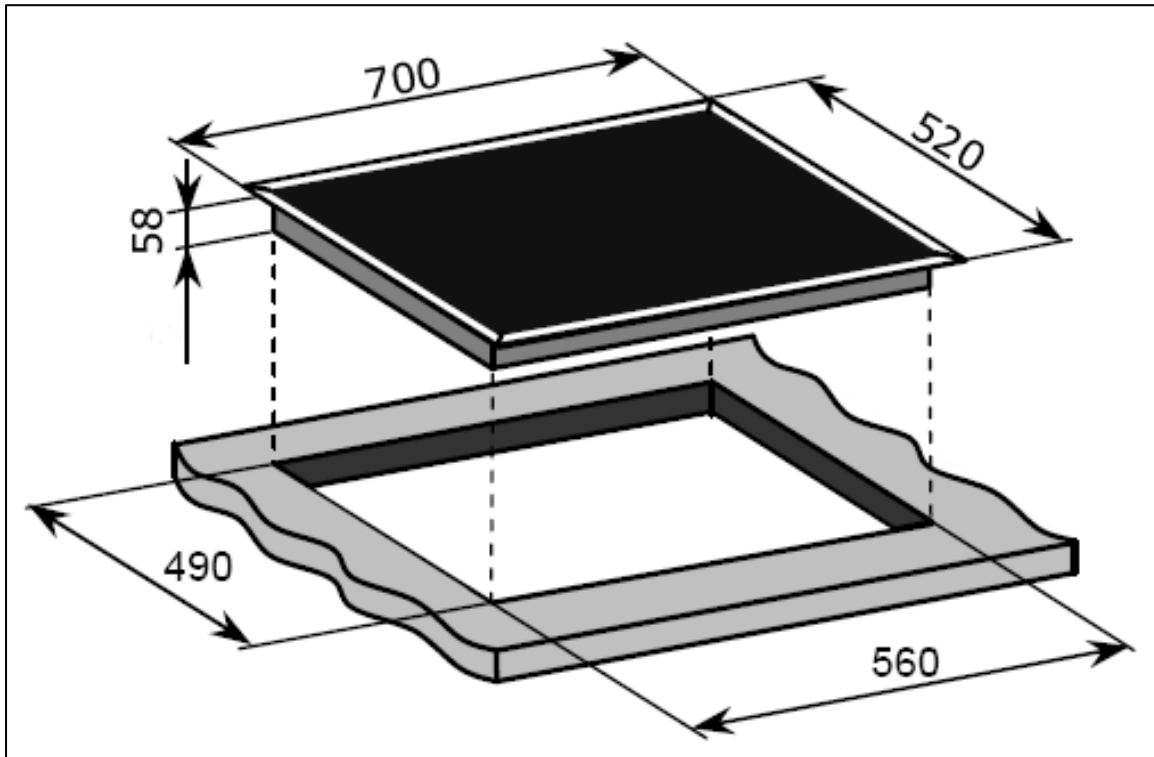

Product dimensions:

Depth: 520 mm
Width: 700 mm
Height: 58 mm

Aperture dimensions:

Depth: 560 mm (+5) mm
Width: 490 mm (+5) mm

Product specifications:

- 1 x 2.00 kW induction zone (Ø 180 mm)
- 2 x 1.40 kW induction zone (Ø 180 mm)
- 1 x 2.00 kW induction zone with booster option (Ø 180 mm)
- Front touch control operation
- Timer
- Auto pan detection
- 2 independent induction generators
- 4 individual residual heat indicators
- Safety lock
- Suitable for installation above built-under ovens. **IMPORTANT: Providing that the specific installation instructions in this manual are followed.**

Standard accessories

- Ceramic hob scraper

Electrical details

Rated Voltage:	230 Vac 50 Hz
Supply Connection:	30 A (double pole switched fused outlet with 3mm contact gap)
Max Rated Inputs:	7.2 kW
Mains Supply Lead:	3 core x 6 mm ² (not supplied)

For future reference please record the following information which can be found on the rating plate and the date of purchase which can be found on your sales invoice. The rating plate of your hob is located on the underneath of the appliance. Therefore it is a good idea to record this information before you install your appliance.

Model Number

Serial Number

Date of Purchase

Ceramic hob surface layout

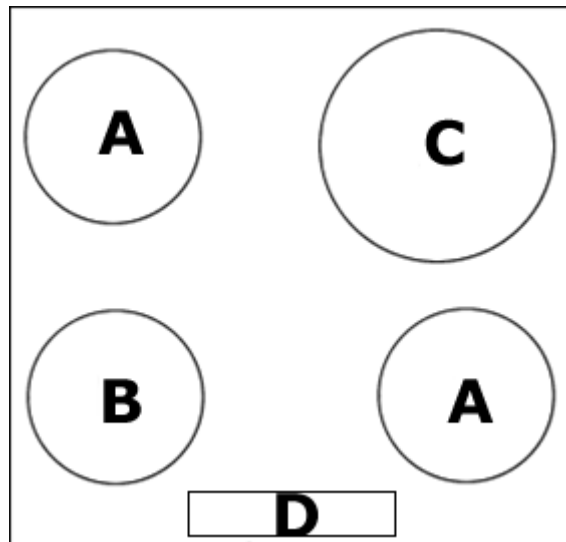

- A = 1.40 kW induction zones (Ø 180 mm)
- B = 2.00 kW induction zone (Ø 180 mm)
- C = 2.00 kW with 2.6 kW booster option (Ø 180 mm)
- D = Control panel

Control panel layout

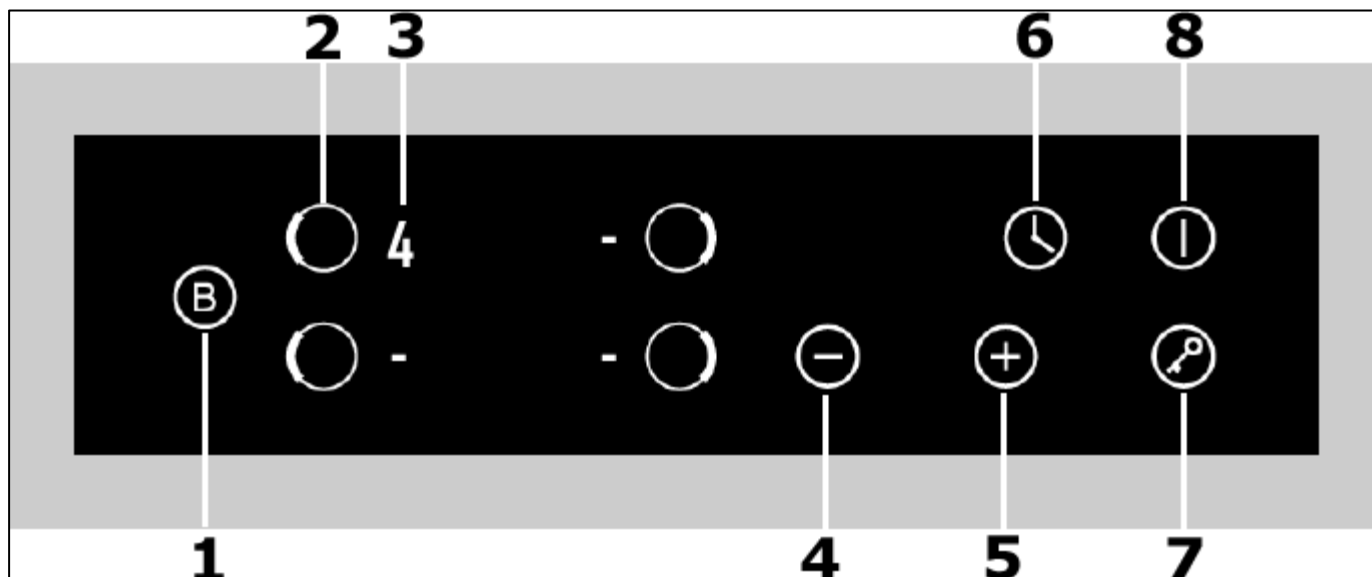

1. Booster button
2. Cooking zone selection buttons (x 4)
3. Cooking zone indicators
4. Minus button
5. Plus button
6. Timer button
7. Safety lock button
8. ON/OFF button

Using the ceramic hob

Before first use



IMPORTANT: You should clean the ceramic hob surface (see "Cleaning and maintenance" section).

- You should switch on one cooking zone at a time, for 5 minutes at the maximum setting. This will help to eliminate any new smell that exists and evaporate any humidity that has formed on the heating elements during transit.
- Do not burn off more than one zone at once.
- **You must** place a saucepan filled half full with cold water on each zone as you burn it off. Otherwise the induction zone will not operate.

Touch controls

- All operations are performed by means of the touch controls that can be found on the control panel.
- Each touch control has a visual display that corresponds to it.

Switching the hob on



- Press the ON/OFF button **(8)**
- The cooking zone indicators **(3)** will all read “-”.

Switching on a cooking zone and setting a power level

IMPORTANT: A cooking zone must be selected within 2 minutes of switching the hob on.



- Press the cooking zone selection button **(2)** of the cooking zone that you want to use.
- Press the plus **(5)** or minus **(4)** button, the cooking zone indicator **(3)** will show power level 5.

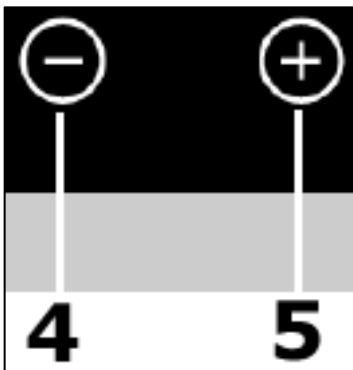

- Press the plus and minus buttons until the cooking zone indicator shows the power level that you require.
- When the power level that you require is reached, release the button that you have been pressing and the cooking zone will start to heat.

- **IMPORTANT:** When a cooking zone is heating, even if the highest power level is selected, it will not glow red permanently. The cooking zone will cycle on and off whilst it is in use. This is normal operation and not a sign of a product fault.

Switching off a cooking zone gradually



- Press the cooking zone selection button **(2)** of the cooking zone that you want to switch off.

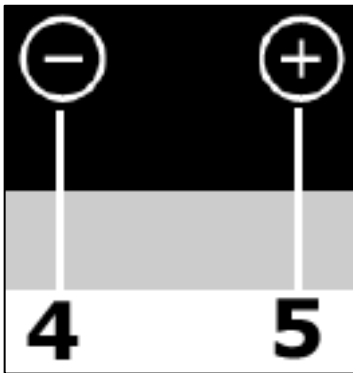

- Press the minus button **(4)** until the number in the cooking zone indicator **(3)** reaches "0". After a few seconds, the zone will switch off automatically.

- A flashing "H" symbol will show in the cooking zone indicator **(3)** until the temperature of the zone falls below 60°C (see the section on the "residual heat indicator" for further information).

Switching off a cooking zone instantly



- Press the cooking zone selection button **(2)** of the cooking zone that you want to switch off.

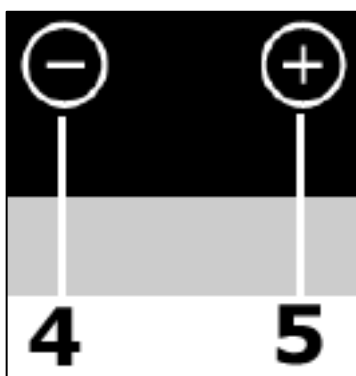

- Press the minus **(4)** and plus **(5)** buttons simultaneously.
- The cooking zone will switch off immediately.

- A flashing "H" symbol will show in the cooking zone indicator **(3)** until the temperature of the zone falls below 60°C (see the section on the "residual heat indicator" for further information).

Switching the hob off



Once you have switched off all of the cooking zones, you should switch off the hob.

- Press the ON/OFF button **(8)**.
- It is possible to switch the hob off at any time by pressing the ON/OFF button.

Residual heat indicator

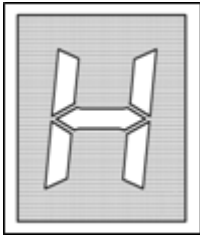

- After a cooking zone is switched off, the corresponding cooking zone indicator **(3)** will show a flashing letter "H". This means that the temperature of the cooking zone is over 60°C and is therefore still high enough to cause injury.
- **IMPORTANT:** The residual heat indicator will disappear if your mains supply is cut.

Booster function

The back right cooking zone has a booster function, when this function is selected, it increases the power output of that particular cooking zone to 2600 watts.



- Press the ON/OFF button **(8)**
- The cooking zone indicators **(3)** will all read "-".
- Press the cooking zone selection button **(2)** for the back right cooking zone and set your desired power level using the plus **(5)** and minus **(4)** buttons.



- Press the booster button **(1)** and the back right cooking zone will operate at its highest power level.
- The letter "P" will appear in the cooking zone indicator **(3)** whilst the booster function is operating.
- After 5 minutes the booster function will cease and the back right cooking zone will return to the power level that you originally set. The letter "P" will be replaced by the number of the power level in the cooking zone indicator.
- If you use the front right cooking zone whilst the booster function is being used, it will not heat above power level 2.

- If you wish to cancel the booster function before the 5 minute time period has elapsed, use the zone selection button to select the back right cooking zone. Then press the booster button **(1)** again and the cooking zone will return to its original power level.
- If you press the minus button, the cooking zone will be set to power level 9.

Pan sensor

Each cooking zone has a sensor on it, so it can detect the presence of a pan.

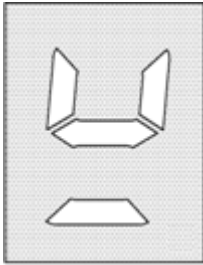

- The sensor is fine-tuned to detect a pan being placed on it. The pan should be one size smaller than the nominal diameter of the cooking zone.
- If the symbol shown above appears on a cooking zone indicator **(3)** after you have placed a pan on a cooking zone and selected it; this means that the pan is either the incorrect size or shape. Or it could be made from a material that is inappropriate for use on an induction zone hob.
- If a cooking zone is selected but no pan is detected, the pan sensor system will check for the presence of a pan approximately every few seconds.
- You should check that your pans are suitable for use on an induction zone hob (see the pan manufacturer's trademark or instructions).

Cookware that is suitable for an induction hob

The table below shows cookware that is normally suitable for use on an induction zone hob:-

Cookware	Suitable
Steel, enamelled steel	Yes
Cast iron	Yes
Stainless steel	Yes (if stated by the pan manufacturer)
Aluminium, copper, brass	No
Glass, ceramic, porcelain	No

- The bottom of the pans should be as flat and thick as possible.

- Certain types of cookware may result in a noise being made when being used on an induction zone hob. This does not mean that there is an appliance fault.
- **IMPORTANT:** You should make sure that all pans are placed in the centre of the induction zone that you are using.

The hob timer (countdown mode)

Your hob has a timer which will countdown a period of time between 1 and 99 minutes. At the end of the countdown period an audible signal will sound.

- Press the ON/OFF button **(8)**.

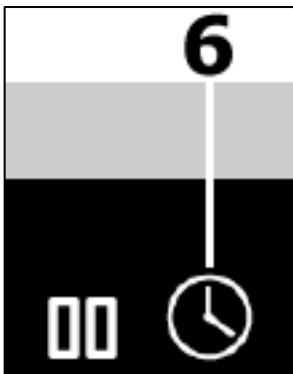

- Press the timer button **(6)** and the timer display will show "00".

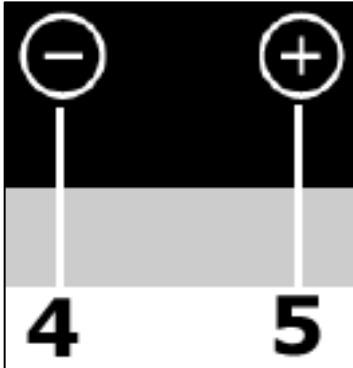

- Use the plus **(5)** and minus **(4)** buttons to set a countdown time of between 1 and 99 minutes.

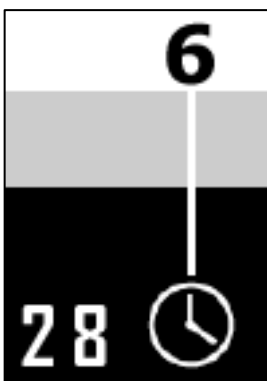

- When the countdown time that you require appears on the timer display, you should release the plus and minus buttons.
- Press the timer button **(6)** again to confirm the countdown time. The timer display will stop flashing and the countdown will commence.

- An audible signal will sound for 30 seconds to advise you that the countdown period has elapsed and the timer display will show “- -”.
- **WARNING: If any of the cooking zones are active at the end of the countdown time, they will not switch off. You will need to switch off the hob cooking zone(s) and hob in the normal manner.**

The hob timer (linked to a cooking zone mode)

- Press the ON/OFF button **(8)**.
- The cooking zone indicators **(3)** will all read “-”.
- Press the cooking zone selection button **(2)** of the cooking zone that you want to use.
- Press the plus **(5)** or minus **(4)** button, the cooking zone indicator **(3)** will show power level 5.
- Press the plus and minus buttons until the cooking zone indicator shows the power level that you require.
- Press the timer button **(6)** and the timer display will show “00”.
- Use the plus **(5)** and minus **(4)** buttons to set a countdown time of between 1 and 99 minutes.
- When the countdown time that you require appears on the timer display, you should release the plus and minus buttons.
- Press the timer button **(6)** again to confirm the countdown time. The timer display will stop flashing and the countdown will commence.
- A red dot will appear in the zone indicator of the cooking zone that has been linked to the timer.
- An audible signal will sound for 30 seconds to advise you that the countdown period has elapsed and the timer display will show “- -”. The cooking zone that has been linked to the timer will switch off automatically.
- **WARNING: If any of the other cooking zones are active at the end of the countdown time, they will not switch off. You will need to switch off the other cooking zone(s) and the hob in the normal manner.**

Locking the hob top



- The whole hob top can be locked by pressing the safety lock button **(7)** whilst the appliance is switched on.
- The timer display will show "L0" to indicate that the safety lock feature has been switched on.
- When the safety lock feature is activated, it will disable all buttons on the control panel **apart** from the ON/OFF button.
- To disable the safety lock feature, you should press and hold the safety lock button **(7)** for a couple of seconds. The "L0" symbol will disappear from the timer display and you are then able to use the hob in normal operation.

Safety cut-off

- If one or more of the cooking zones are accidentally left on, a safety cut off will activate after a certain period of time. The length of time depends on the power level that a cooking zone or zones have been set on.

LEVEL	TIME LIMIT (hours)
1 - 3	8
4 - 6	4
7 - 9	2

- If more than one cooking zone is operating when one of the cooking zones reaches its safety cut-off point, only this cooking will switch off. Any other cooking zones that are in use will remain active.

Hob guidelines

- The first few times the hob top is used, it may give off an acrid, burning smell. This smell will disappear completely with repeated use.
- The worktop is fitted with cooking areas of different diameter and power.
- The positions where the heat will radiate from are clearly marked on the hob top. The saucepans must be positioned exactly on these zones for efficient heating to occur. Pans should have the same diameter as the cooking zone that they are being used on.
- You should not use saucepans with rough bottoms, as this can scratch the ceramic surface.
- Before use, make sure that the bottoms of the saucepans are clean and dry.
- When cold, the bottom of the pans should be slightly concave, as they expand when hot and lie flat on the surface of the hob. This will allow the heat to transfer more easily.
- The best thickness for the bottom of the pans is 2 – 3 mm of enamelled steel and 4 – 6 mm for stainless steel with sandwich type bottoms.
- If these rules are not followed, then there will be a great loss of heat and energy. Heat not absorbed by the saucepan, will spread to the hob, frame and surrounding cabinets.
- Preferably cover pans with a lid to permit cooking at a lower heat.
- Always cook vegetables and potatoes, etc. in as little water as possible to reduce cooking times.
- Food or liquid that has high sugar content may damage the hob top if it comes into contact with the ceramic hob surface. Any spillages should be wiped up immediately, however this may not prevent the hob surface from becoming damaged.
- ***IMPORTANT:*** *The ceramic hob surface is tough; however it is not unbreakable and can be damaged. Especially if pointed or hard objects are allowed to fall on it with some force.*

- **DO NOT USE THE HOB IF THE SURFACE BECOMES BROKEN OR CRACKED. YOU SHOULD CONTACT THE BAUMATIC CUSTOMER CARE DEPARTMENT IMMEDIATELY.**

Cleaning and maintenance



Cleaning operations must only be carried out when the hob is cool.

The appliance should be disconnected from your mains supply before commencing any cleaning process.

Cleaning the ceramic hob top



Any residues that are left on the hob top surface from cleaning agents **will** damage it. You should remove any residues with water and a little washing up liquid.



Abrasive cleaners or sharp objects will damage the hob surface; you should clean it using water and a little washing up liquid.



Although it is easier to clean some deposits whilst the hob surface is still warm. You should take care not to burn yourself if cleaning the hob surface when it is still warm.

After each use

- Wipe the appliance over with a damp cloth and a little washing up liquid.
- Dry the appliance by rubbing the surface with a clean cloth.

Cleaning table

Type of deposit	Remove immediately?	Remove when the appliance has cooled down?	What should I use to remove the deposit?
Sugar or food/liquid containing sugar	Yes	No	Ceramic hob scraper
Tin foil or plastic	Yes	No	Ceramic hob scraper
Fat splashes	No	Yes	Ceramic hob cleaner
Metallic discolourations	No	Yes	Ceramic hob cleaner
Water splashes or water rings	No	Yes	Ceramic hob cleaner

Using a ceramic hob scraper

A ceramic hob scraper will be provided with your appliance. The following guidelines should be followed when using the ceramic hob scraper:-

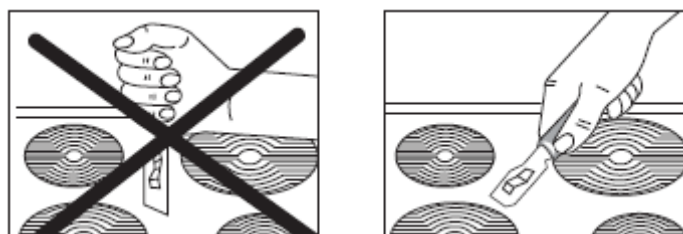

- The scraper should be placed on the ceramic surface at an angle.
- Residues should be removed by sliding the blade carefully over the ceramic surface.
- The ceramic surface should be wiped with a damp cloth and a small amount of washing up liquid.
- Dry the appliance by rubbing the surface with a clean cloth.

Using a specialist ceramic hob cleaner

It is possible to purchase specialist ceramic hob cleaner/conditioner.

You should follow the instructions given by the manufacturer of the specialist ceramic hob cleaner. You should ensure that it is suitable for use on your appliance.

Installation



The installation must be carried out by a suitably qualified person, in accordance with the current version of the following.

- ***UK Regulations and Safety Standards or their European Norm Replacements.***
- ***Building Regulations*** (issued by the Department of the Environment).
- ***Building Standards*** (issued by the Scottish Development Department).
- ***IEE Wiring Regulations.***
- ***Electricity At Work Regulations.***

Positioning



The adjacent furniture must be able to withstand a minimum temperature rise of 85°C above the ambient temperature of the room it is located in, during periods of use.

This appliance is classified as Class 3 and therefore is to be built into a kitchen unit (depending on size) or 600 mm worktop that is between 25 mm and 40 mm thick. The following minimum clearance distances must be observed:-

- 700 mm between the hob surface and the underside of any horizontal surface above it.
- 50 mm clearance around the sides and front of the appliance.
- 55 mm clearance between the back of the hob surface and the wall behind it.
- If the hob is positioned so that the right or left hand side of the appliance will be near to the edge of a kitchen unit. There must be a gap of at least 150 mm between the side of the hob and the vertical surface of the kitchen unit.

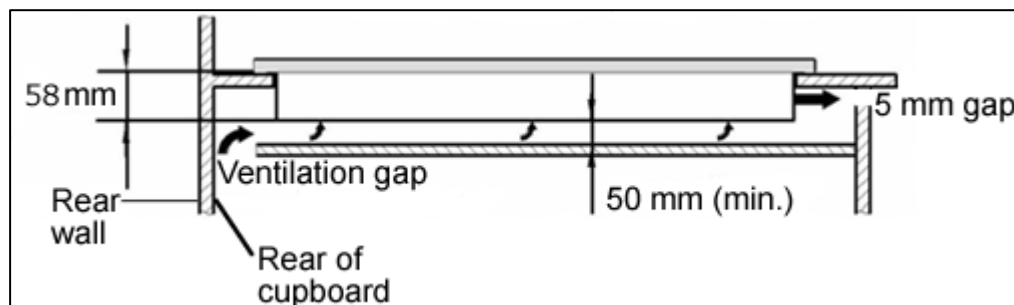

○

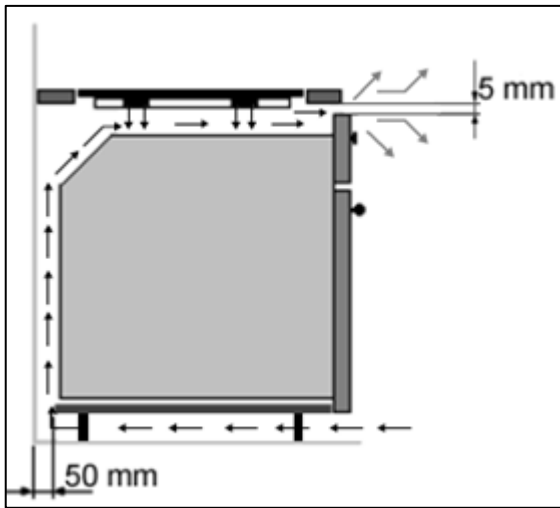

- **IMPORTANT:** Underneath the appliance there must be a partition made of insulating material (e.g. wood). There must be a gap of at least 50 mm between the underneath of the appliance and this partition.

- You must make sure that there is a 5mm gap below the underneath of the worktop at the front edge of the hob.

Installing above a built under oven

IMPORTANT: If you are building this hob above an oven, the oven **MUST** have a cooling fan.

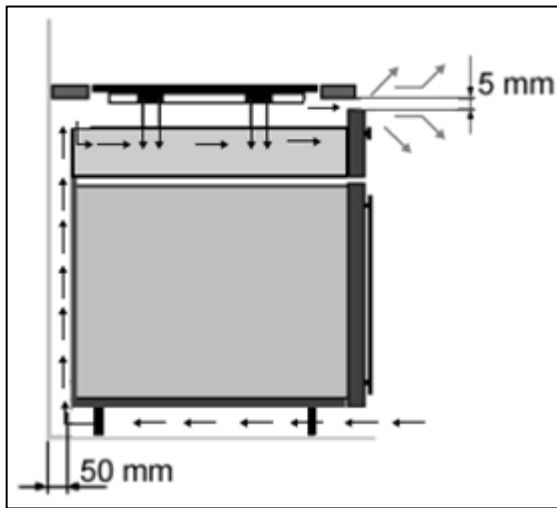

- There must be a gap of at least 50 mm between the underneath of the appliance and the top of the oven.
- You must make sure that there is a 5mm gap below the underneath of the worktop at the front edge of the hob.

Unpacking the appliance

When unpacking the appliance please check that the following items are contained within the packaging:-

- 1 Baumatic hob
- 1 Ceramic hob scraper
- 1 Installation and instruction manual
- 1 Baumatic guarantee card
- 4 Fixing brackets
- 4 Fixing screws
- 1 Sealing strip

Installing the appliance

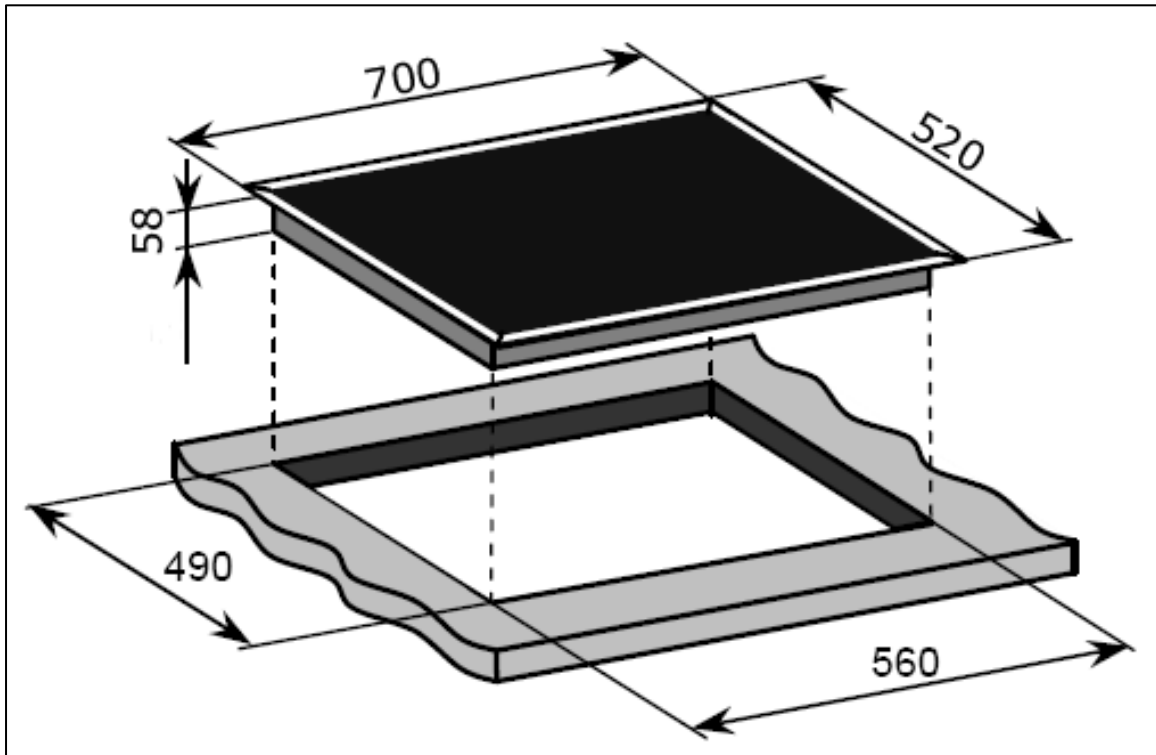

- Cut a hole in the worktop that corresponds with the drawing shown above.

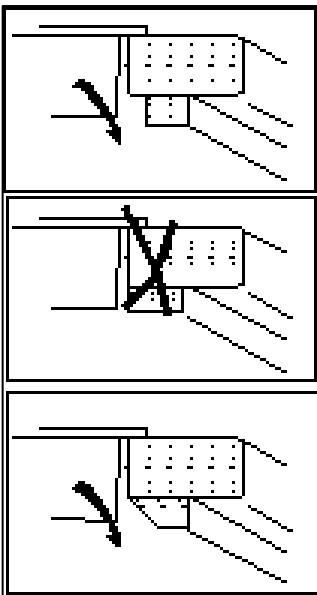

- **IMPORTANT:** *There are ventilation holes around the outside of the hob. YOU MUST ensure that these holes are not blocked by the work top, when you put the hob into position (see drawing opposite).*
- Carefully turn the hob upside down and place it on a cushioned mat.

- **IMPORTANT:** Do not use a silicon sealant to seal the appliance against the aperture. This will make it difficult to remove the hob from the aperture in future, particularly if it needs to be serviced.

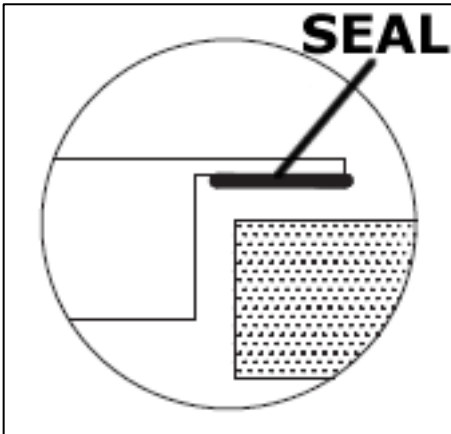

- A seal will already be fixed to the underneath of the hob when it is supplied.

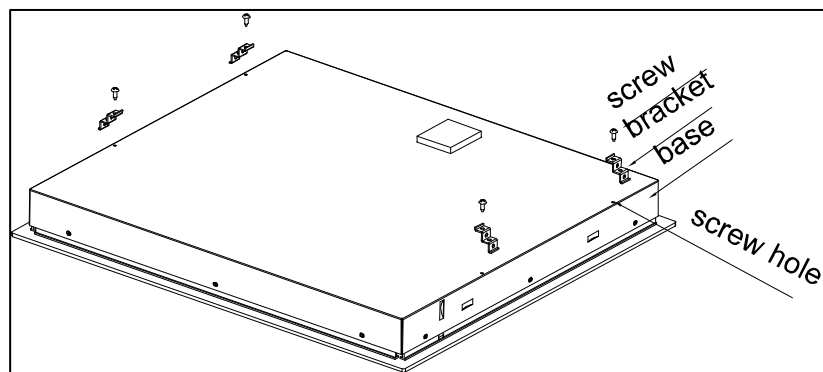

- Carefully turn the hob back over and then gently lower it into the aperture hole that you have cut out.
- There are holes on the base or the sides of the hob that you can fix the four brackets to. There are three holes in each one of the brackets.



- You should place the bracket on the underneath of the hob, in a position that is appropriate for the aperture that you have cut out. Using the screws provided, fix the bracket to the hob. These screws **MUST** be securely tightened.

Electrical connection



This appliance must be installed by a qualified person in accordance with the latest edition of the I.E.E. Regulations and in compliance with Baumatic's instructions.

Before connecting the appliance, make sure that the supply voltage marked on the rating plate corresponds with your mains supply voltage.

WARNING: THIS APPLIANCE MUST BE EARTHED.

- This appliance must be wired into a 30 A double pole switched fused spur outlet, having 3 mm contact separation and placed in an easily accessible position adjacent to the appliance. It should not be located above the appliance and no more than 1.25m away from it.
- The spur outlet must still be accessible even when your hob is located in its operating position.
- Cable type: H05 RRF 3 core x 6 mm²

Connecting the mains supply cable

- The mains terminal block is located on the underside of the hob and the terminals are accessible by removing the terminal block cover by removing the cover screw.

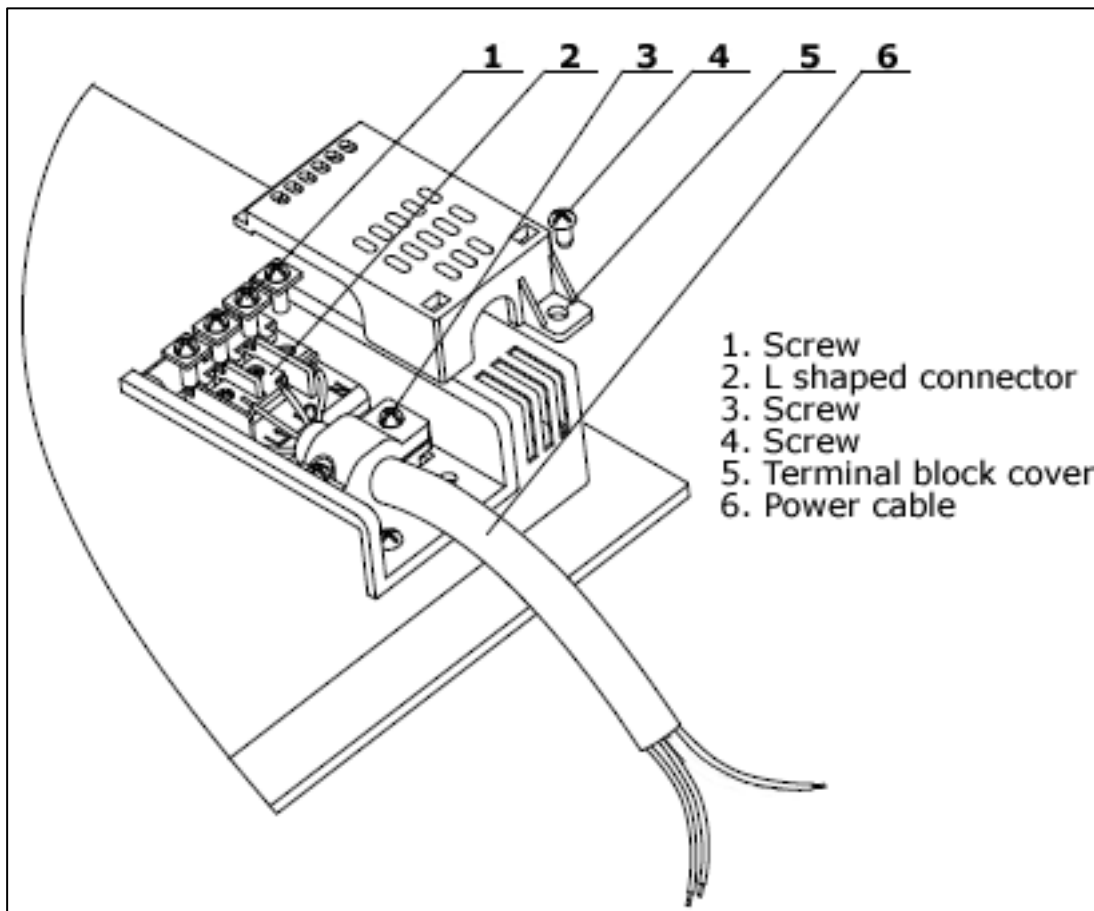

1. Screw
2. L shaped connector
3. Screw
4. Screw
5. Terminal block cover
6. Power cable

Voltage&frequency	Wire connection				
400V 2-N 50\60HZ	1 • L1 Black	2 • L2 Brown	3 • Gray	4 • N Blue	5 • Yellow/Green Ground symbol
220-240V 50\60HZ	1 • Brown	2 • L	3 • Blue	4 • N	5 • Yellow/Green Ground symbol
220-240V 2+2-N 50\60HZ	1 • L1 Black	2 • L2 Brown	3 • N1 Gray	4 • N2 Blue	5 • Yellow/Green Ground symbol

- The cable connections must be in accordance with the diagram located on the bottom of the hob (see above)
- The brass links must be positioned as marked in the appropriate diagram. Once established, you should use a good quality screwdriver to carefully fully tighten ALL of the terminal screws.

- ***If when the hob is first switched on, only two of the zones work, you should recheck that the terminal screws are all fully tightened and that the links are securely in place. This should be done before contacting the Baumatic Customer Care Department***
- ***IMPORTANT:*** *The appliance must NOT be connected to the mains supply by means of a 13A plug and socket.*
- The cable can be looped if necessary, but make sure that is not kinked or trapped when the hob is in position. Care must be taken to avoid the cable being in contact with hot parts of the appliance.

Replacing the mains supply cable

If the mains supply cable is damaged, then it must be replaced by an appropriate replacement.

The mains supply cable should be replaced in accordance with the following instructions:

- ***Switch the appliance off at the control switch.***
- Open the terminal block on the underside of the hob.
- Unscrew the terminal screws fixing the cable.
- Replace the cable with one of the same length and in accordance with the specification given on page 27.
- The “green-yellow” earth wire must be connected to the terminal marked \perp . It must be about 10 mm longer than the live and neutral wires.
- The “blue” neutral wire must be connected to the terminal marked with letter (N) - the “brown” live wire must be connected to the terminal marked with letter (L).

My appliance isn't working correctly

- ***The cooking zones are not functioning or will not switch on.***
 - * It has been more than 2 minutes since a zone was switched on. You should switch a zone on again, using the relevant zone ON/OFF button.
 - * The safety lock has been switched on (see the "Locking the hob top" section for information on how to switch off the safety lock).
 - * Several cooking zone selection buttons have been pressed at once. You should only touch one cooking zone selection button at a time.
 - * The safety cut out has been triggered. Press a zone selection button to reset the hob.
 - * Check that the mains electrical supply to the appliance is correct and working. Check the mains fuse.
 - * The pans that you are using are not suitable for use on an induction hob.
- ***The residual heat indicator has not come on after I have switched a cooking zone off.***
 - * The cooking zone has only been turned on for a short period of time; therefore it did not go above 60°C.
 - * ***IMPORTANT:*** *If the cooking zone does appear to be hotter than 60°C and the residual heat indicator has not come on, you should call the Baumatic Customer Care Department.*
- ***A humming sound is heard when a cooking zone is selected.***
 - * This is normal; the sound will disappear when the zone heats up.
- ***The cooking zones have become discoloured.***
 - * This maybe caused by burnt on remnants of food. This will not affect the working of the appliance. However you should make sure that the cleaning instructions are being followed regularly.

Error codes

The following error codes may appear in the timer display if there is a problem with the operation of the hob.

Fault	Possible cause	Solutions
FO/F1/F2	Fan failure	Contact Customer Care
F3 – F8	Temperature sensor failure	Contact Customer Care
E1 – E2	Abnormal voltage from the mains supply	Check whether the power supply is operating normally.
E3 – E4	Abnormal temperature	Check that the pan is of the correct size to be used on a particular zone. If the pan is correctly sized and the error code reappears, contact Customer Care.
E5 – E6	Poor heat radiation from a cooking zone	Allow the appliance to cool down and then use the cooking zone again. If the error code reappears, contact Customer Care.



IMPORTANT: If your appliance appears not to be operating correctly, then you should disconnect it from your mains supply and then contact Baumatic Customer Care on telephone number (0118) 933 6911.

DO NOT ATTEMPT TO REPAIR THE APPLIANCE YOURSELF.

Please note that if an engineer is asked to attend whilst the product is under guarantee and finds that the problem is not the result of an appliance fault, then you may be liable for the cost of the call out charge.

The appliance must be accessible for the engineer to perform any necessary repair. If your appliance is installed in such a way that an engineer is concerned that damage will be caused to the appliance or your kitchen, then he will not complete a repair.

This includes situations where appliances have been tiled in, sealed in with sealant, have wooden obstructions placed in front of the appliance, like plinths. Or any installation other than the one specified by Baumatic Ltd. has been completed.

Please refer to the conditions of guarantee that appear on the warranty card that you receive with the appliance.

IMPORTANT: Baumatic Ltd. operates a policy of continuous improvement and reserves the right to adjust and modify its products without prior notification.



United Kingdom

Baumatic Ltd.,
Baumatic Buildings,
6 Bennet Road,
Reading, Berkshire
RG2 0QX
United Kingdom

Sales Telephone

(0118) 933 6900

Sales Fax

(0118) 931 0035

Customer Care Telephone

(0118) 933 6911

Customer Care Fax

(0118) 986 9124

Spares Telephone

(01235) 437244

Advice Line Telephone

(0118) 933 6933

E-mail:

sales@baumatic.co.uk
customercare@baumatic.co.uk
spares@baumatic.co.uk
technical@baumatic.co.uk

Website:

www.baumatic.co.uk

Republic of Ireland

Service Telephone

1-890 812 724

Spares Telephone

091 756 771

Czech Republic

Baumatic CR spol s.r.o.
Průmyslová zóna Sever 696
460 11 Liberec 11
Czech Republic

+420 483 577 200

www.baumatic.cz

Slovakia

Baumatic Slovakia, s.r.o.
Galvániho 7/D
Slovakia

+421 255 640 618

Germany

Baumatic Gmbh
Lilienthalstrasse 1
320 52 Herford
Deutschland

+49 5221 694 99-0

www.baumatic.de

Italy

Baumatic Italia S.R.L.
Via Galvani N.3
35011 Campodarsego (PD)

+3904 9920 2297

www.baumatic.it

Holland

Baumatic Benelux B.V.
Grindzuigerstraat 22
1333 MS ALMERE
Nederland

+3136 549 1555

www.baumatic.nl

