

**BTM25.7SS 25 Litre
combination microwave
oven with grill**

INSTRUCTION MANUAL

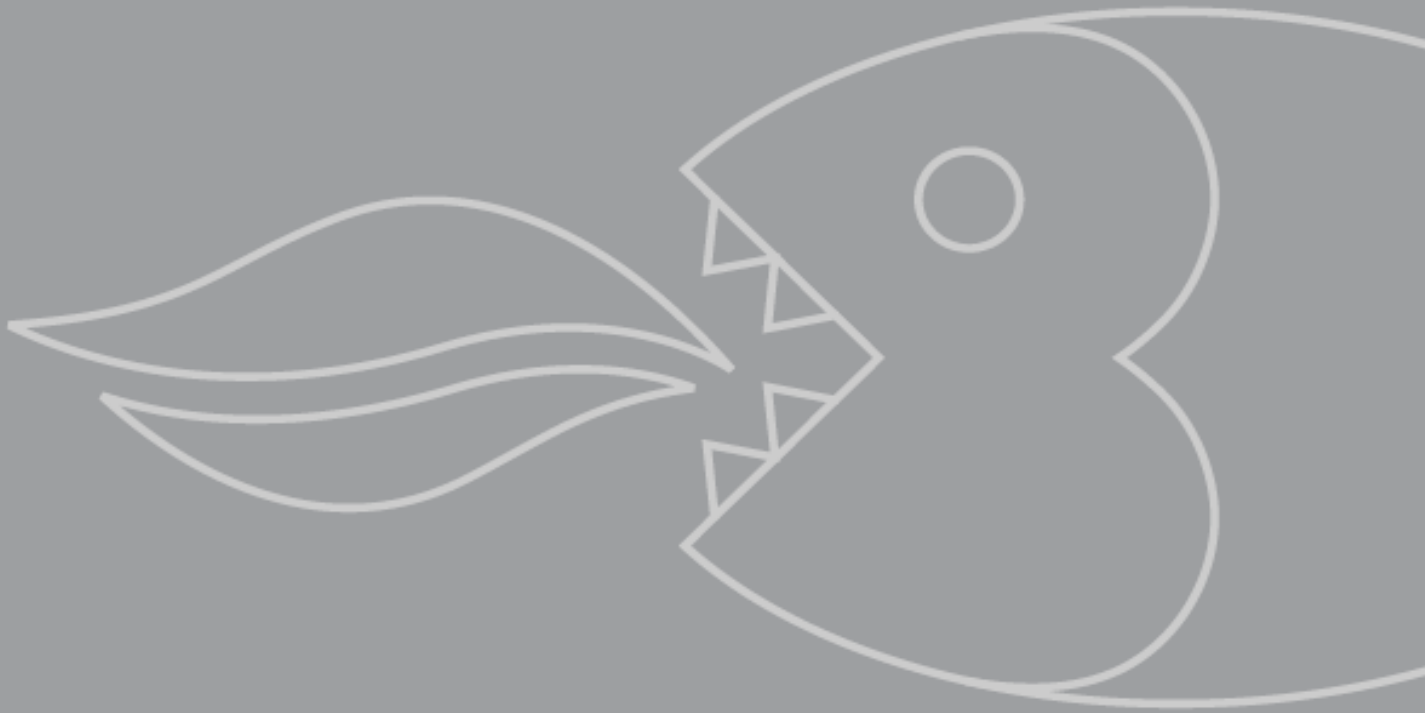

User Manual for your Baumatic

BTM25.7SS

25 Litre combination microwave oven
with grill



NOTE: This User Instruction Manual contains important information, including safety & installation points, which will enable you to get the most out of your appliance. Please keep it in a safe place so that it is easily available for future reference; for you or any person not familiar with the operation of the appliance.

GS 20/02/12

Contents

Environmental note	4
Important safety information	5 – 9
Specifications	9 – 13
Product dimensions	9
Product specifications	9
Electrical details	9
Description of the appliance	10 - 11
Control panel	11
The turntable	12
LED display	12 - 13
Using your microwave	13 – 28
Setting the clock	13
Before first use	13
Microwave cooking	14 - 15
Microwave power level chart	15
Time setting chart	15
Convection / Combination cooking	16 – 17
Convection / Combination chart	17
Convection cooking table	17 – 18
Grill / Combination cooking	18 – 19
Grill function chart	19
Auto defrost	19 – 20
Defrost program chart	20
Defrost guide	20 – 21
Auto cooking	21 – 22
Auto cooking chart	22 – 23
Delay start function	23 – 24
Multi-sequence cooking	24 – 25
Safety lock	25 – 26
Microwave cooking guidelines	26 – 27
Materials you can use for microwave cooking	27
Materials you cannot use for microwave cooking	28
Utensils table	28
Cleaning and maintenance	29 – 30
The appliance exterior	29
The appliance interior	29
Turntable and turntable support	29
General cleaning advice	29 - 30
Installation	30 – 32
Electrical connection	30 – 31
Fitting the distance limiter	32
Positioning	32
My appliance isn't working correctly	33 – 34
Baumatic consumables	35
Contact details	36

This appliance is marked according to the European directive 2002/96/EC on Waste electrical and Electronic Equipment (WEEE). By ensuring this product is disposed of correctly, you will help prevent potential negative consequences for the environment and human health, which could otherwise be caused by inappropriate waste handling of this product.

The symbol  on the product, or on the documents accompanying the product, indicates that this appliance may not be treated as household waste. Instead it shall be handed over to the applicable collection point for the recycling of electrical and electronic equipment.

Disposal must be carried out in accordance with local environmental regulations for waste disposal.

For more detailed information about treatment, recovery and recycling of this product, please contact your local city office, your household waste disposal service or the shop where you purchased the product.



- The packaging materials that Baumatic uses are environmentally friendly and can be recycled.
- Please discard all packaging material with due regard for the environment.

IMPORTANT SAFETY INFORMATION



Your safety is of the utmost importance to Baumatic. Please make sure that you read this instruction booklet **before** attempting to install or use the appliance. If you are unsure of any of the information contained in this booklet, please contact the Baumatic Customer Care Department.

General Information

- This appliance is designed for domestic household use. It can **NOT** be used as a built in microwave and must be freestanding.
- You should only operate the appliance when the turntable and turntable support are in position.
- You should only use ovenware that is suitable for being used in a microwave.
- To prevent corrosion occurring due to moisture/condensation, the cavity and the door of the microwave should be wiped dry after each use of the appliance.
- The appliance must not be left unattended if you are heating or cooking food in containers that are made of paper, plastic or other flammable materials. If left unattended, they could pose a **fire hazard**.
- If you notice smoke coming from the appliance, you should keep the door of the microwave closed and then disconnect it from your mains supply. **DO NOT** use your microwave oven, if you think it is not operating correctly.

Installation

- **IMPORTANT:** *Only the installation sanctioned by Baumatic and outlined in this manual should be followed.*
- **IMPORTANT:** *The adjacent furniture and all materials used in the installation **must** be able to withstand a minimum temperature of 85°C above the ambient temperature of the room it is located in, whilst in use.*
- Certain types of vinyl or laminate kitchen furniture are particularly prone to heat damage or discolouration at temperatures below the guidelines given above.

- Any damage caused by the appliance being installed in contravention of this temperature limit, or by placing adjacent cabinet materials closer than 4mm to the appliance, ***will be the liability of the owner.***
- For use in ***leisure accommodation vehicles***, please refer to the appropriate information given in the installation instructions for this appliance.
- The use of this appliance for any other purpose or in any other environment without the express agreement of Baumatic Ltd. will invalidate any warranty or liability claim.
- Your new appliance is guaranteed against electrical or mechanical defects, subject to certain exclusions that are noted in Baumatic's Conditions Of Guarantee. The foregoing does not affect your statutory rights.

Service

- Your microwave complies with all relevant safety standards. In order for it to continue to operate safely, ***only an engineer that is approved by the Baumatic Customer Care Department should work on the appliance.***
- ***IMPORTANT:*** *It is dangerous for a non qualified person to work on the appliance, in particular if they remove the cover that provides protection against exposure to microwave energy.*
- If you notice that the door seal, door surfaces, power cord and plug are damaged. You should stop using the appliance, disconnect it from the mains supply and contact the Baumatic Customer Care Department.
- Only genuine Baumatic spare parts should be fitted to your appliance. These can be obtained from the Baumatic Spares Department.

Warning and safety instructions

- This appliance complies with all current European safety legislation. Baumatic do wish to emphasise that this compliance does not remove the fact that the appliance surfaces ***will become hot during use and retain heat after operation.***
- ***DO NOT*** place anything between the door and the door frame.
- ***DO NOT*** store anything that is flammable inside of the microwave. When it is switched on, the items could catch fire.

- **DO NOT** switch the appliance on if there is no food or liquid inside of the microwave. If you run the microwave whilst it is empty, there is a chance that it will overload.
- The door seals and the door surfaces should ALWAYS be kept clean and free from debris.

Child Safety

- Baumatic strongly recommend that babies and young children are prevented from being near to the appliance and not allowed to touch the appliance **at any time**.
- If it is necessary for younger family members to be in the kitchen, please ensure that they are kept under close supervision at all times.
- **IMPORTANT:** *This appliance should only be operated by adults. You SHOULD NOT allow young children to use the microwave without supervision. Older children should only operate the appliance if they have been thoroughly instructed on how to use the microwave and the consequences of improper usage.*

General Safety

- **Do not** allow electrical fittings or cables to come into contact with areas on the appliance that get hot.
- **Do not** use the appliance to heat the room it is located in.
- **Do not** use the appliance to dry paper, textiles or animals.
- **Do not** install the appliance next to curtains or soft furnishings.
- **Do not** use the appliance to heat unopened bottles or cans etc.
- **Do not** heat cooking oil or liquid containing alcohol, as there is the chance of spontaneous combustion.
- **Do not** boil eggs or similar foods in their shells, otherwise they may burst. It is possible to poach eggs in your microwave, providing you prick the yolks first.
- **Do not** attempt to lift or move cooking appliances by using the oven door, as this may cause damage to the appliance or result in injury to the person lifting the appliance.

Cleaning

- Cleaning of the oven should be carried out on a regular basis.
- Great care should be taken whilst using this appliance and when following the cleaning procedure.
- ***IMPORTANT:*** *The appliance must be disconnected from the mains before following the cleaning procedure.*

Installation



This appliance must be correctly installed by a suitably qualified person, strictly in accordance with the manufacturer's instructions.

- ***Baumatic Ltd. declines any responsibility for injury or damage, to person or property, as a result of improper use or installation of this appliance.***
- Heat, steam and moisture will be created during use of the appliance, take care to avoid injury and ensure that the room is adequately ventilated. If the appliance is going to be used for prolonged periods of time, then additional ventilation may be required.
- Please consult with your qualified installer if you are in any doubt about the amount of ventilation that you will require.

Declaration of conformity

- **CE:** Appliance conforming to the European directives 89/336/EEC, 93/68/EEC, 73/23/EEC and subsequent revisions and "RoHS" directive 2002/95/CE.*
- The manufacturer declares that the oven is built using certified materials and requires the appliance to be installed in accordance with the standards currently in force. This appliance must be used by a trained person for domestic purposes only.
- * The RoHS directive stands for "the restriction of the use of certain hazardous substances in electrical and electronic equipment". This directive bans the placing on the EU market of new electrical and electronic equipment containing more than the agreed levels of lead, cadmium, mercury, hexavalent chromium, polybrominated biphenyl (PBB) and polybrominated diphenyl ether (PBDE) flame retardants.

Specifications

Product dimensions

Height: 303 mm
Width: 509 mm
Depth: 472 mm

Product specifications

8 functions:

- Rice / Pasta
- Fresh vegetables
- Frozen vegetables
- Popcorn
- Beverages
- Potatoes
- Pizza
- Fish

- 5 power levels
- LED full programmer with temperature and function display
- Pushbutton operation
- Internal light
- Quick start function
- Safety lock
- Stainless steel interior
- Defrost by weight
- Capacity: 25 litres
- Microwave output: 900 W
- Grill output: 1000 W
- Hot air output: 1300 W

Standard accessory

- Grill rack

Electrical details

Rated Voltage: 220 - 240 Vac 50 Hz
Supply Connection: 13 A (double pole switched fused outlet with 3mm contact gap)
Max Rated Inputs: 1.40 kW
Mains Supply Lead: 3 x 1.5 mm²

For future reference please record the following information which can be found on the rating plate and the date of purchase which can be found on your sales invoice. The rating plate for your oven can be located by opening the microwave oven door and looking on the right hand side of the chassis.

Model Number

Serial Number

Date of Purchase

Description of the appliance

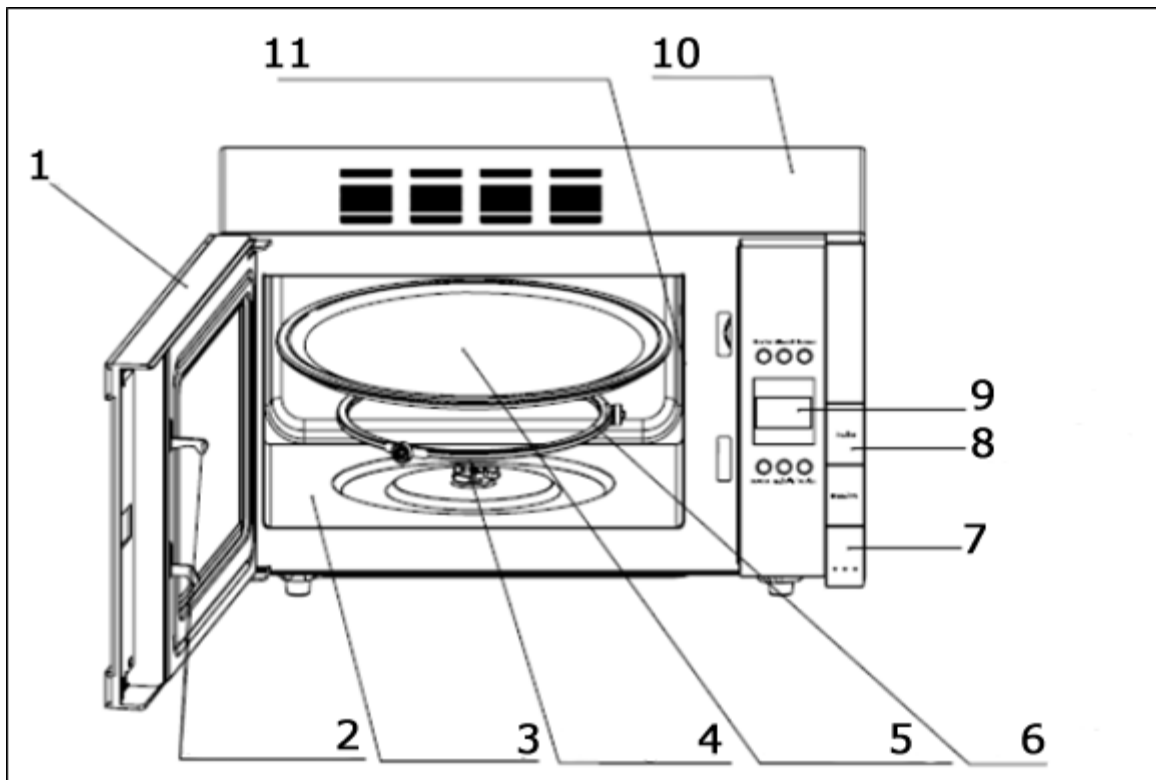

- 1) Microwave oven door
- 2) Microwave door latch
- 3) Microwave oven cavity
- 4) Rotating axis
- 5) Glass turntable
- 6) Rotating ring
- 7) Microwave door release button
- 8) Outer control panel
- 9) Inner control panel
- 10) Microwave oven exterior
- 11) Waveguide cover (inside)

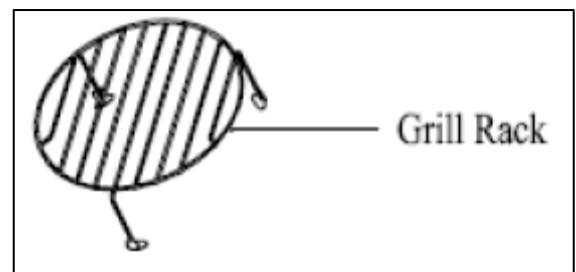

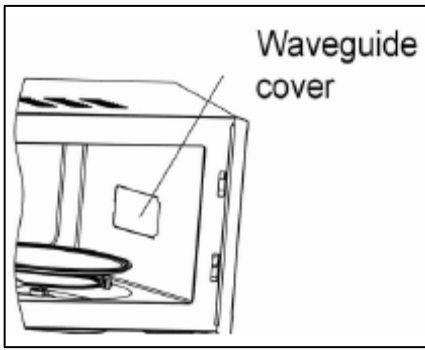

IMPORTANT: You should NEVER remove the waveguide cover.

Control panel

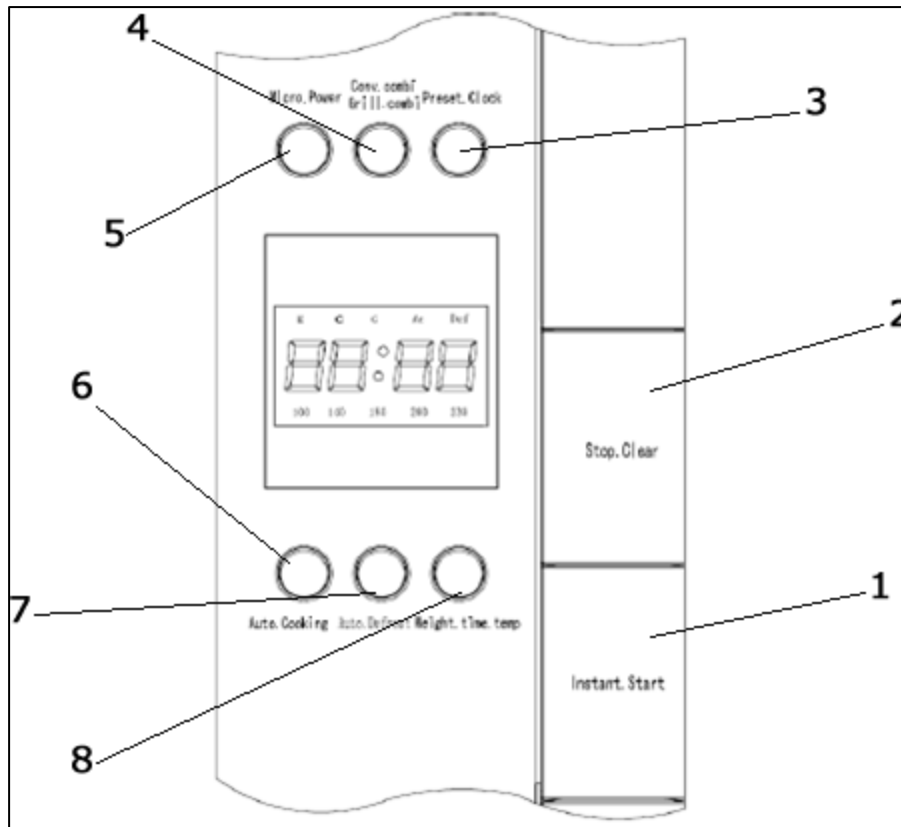

- 1) Instant Start button
- 2) Stop. Clear button
- 3) Preset. clock button
- 4) Convection combi / grill combi button
- 5) Microwave power button
- 6) Auto cooking button
- 7) Auto defrost button
- 8) Weight. Time. Temperature button

The turntable

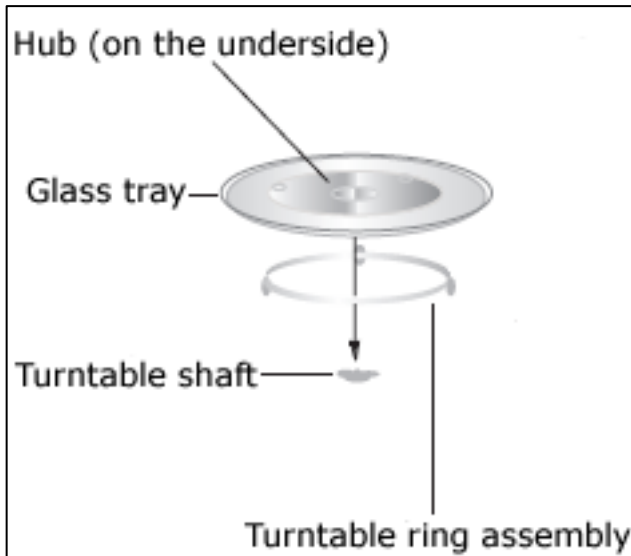

- **Never** place the glass tray upside down.
- The glass tray and turntable ring assembly **MUST** always be used during cooking.
- All food and food containers must **ALWAYS** be placed on the glass tray during cooking.

- If the glass tray or turntable ring assembly cracks or breaks, it must be replaced immediately. Genuine Baumatic parts can be obtained from the Baumatic Spares Department.

LED display

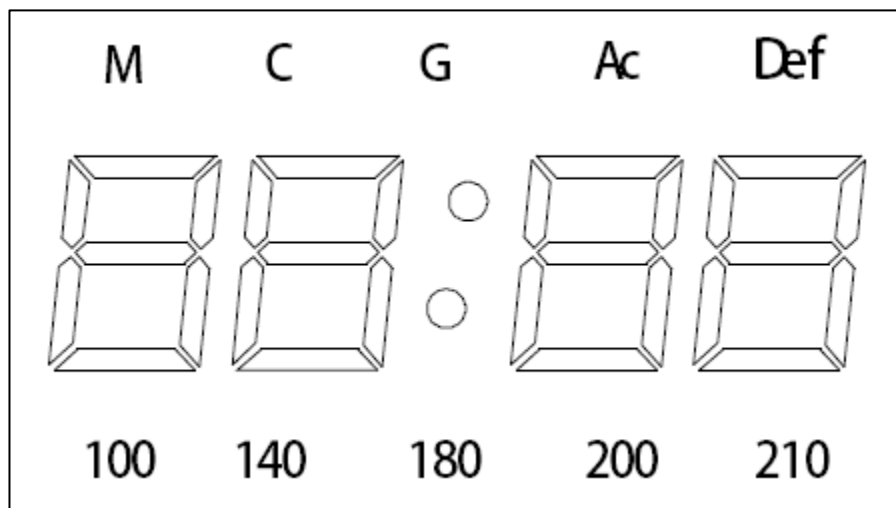

- The LED display will show the time of day, or if the microwave is in use, it will show the cooking time.

M Indicates that the microwave cooking function has been selected

C Indicates that the convection cooking function has been selected

G Indicates that the grill cooking function has been selected

Ac Indicates that an automatic cooking program has been selected

Def Indicates that a defrost program has been selected

100	140	180	200	210
-----	-----	-----	-----	-----

Indicates which oven temperature has been selected



WARNING: The accessible surface may be hot during operation and for a period of time afterwards.

Using your microwave

Setting the clock

- When your appliance is connected to the power supply for the first time, the " : " on the LED display will flash.
- Press the Preset.Clock button **(3)** once.
- Use the Auto Defrost button **(7)** or Weight.Time.Temp button **(8)** to set the correct hour.
- Press the Preset.Clock button **(3)** again to confirm.
- Use the Auto Defrost button **(7)** or Weight.Time.Temp button **(8)** to set the correct minutes.
- Press the Preset.Clock button **(3)** again to confirm or wait 5 seconds until the time is set.

Before first use

- To remove any residue from the oven that may have been left from the manufacturing process, you should place a cup that is half filled with water in the microwave.
- Set the microwave on its highest power level for 2 minutes.
- The oven cavity and outside of the appliance should be cleaned with warm soapy water, using either a sponge or soft cloth. No abrasive cleaners should be used. The appliance should be thoroughly dried afterwards.
- When the microwave is connected to the power supply, the LED display will flash 3 times. It will then flash " : " to prompt you to input a cooking function and time.

Microwave cooking

- Use the door release button to open the door of the microwave.
- Check that the turntable shaft, turntable ring assembly and glass tray are correctly assembled in the cavity.
- Place whatever you are cooking in the centre of the microwave cavity.
- Press the Stop.Clear button **(2)** once when the colon flashes on the LED display.
- Select the required microwave power by pressing the microwave power button **(5)** repeatedly.
- You can then set the desired cooking time by pressing the Weight.Time.Temp button **(8)** to decrease and the Auto Cooking button **(6)** to increase. The maximum time that can be set is 99 minutes and 99 seconds.
- Close the microwave oven door and press the Instant Start button to begin cooking. The LED display will count down to show the remaining cooking time.
- If you turn the food during the cooking process, press the door release button to turn the food. Close the door again and press the Instant Start button to continue the cooking procedure.
- If you wish to remove the food before the preset time, you must press the Stop.Clear button **(2)** once to clear the preset program to avoid unintended operation during next use.
- At the end of the cooking time, the LED display will show "End" and 3 beeps will sound to prompt you to remove the food from the microwave. If you do not press the Stop.Clear button **(2)** once or open the door, the beep will sound every 3 minutes.
- ***IMPORTANT:*** *The inside of the microwave and the food that you have been cooking may be extremely hot. So care should be taken when removing items from the microwave. We would recommend that you use an oven glove.*
- After the food has been removed from the microwave, you should make sure that the door is closed.

IMPORTANT: Never use the grill rack during microwave cooking.

IMPORTANT: Never operate the microwave empty.

Microwave power level chart

<i>Power level</i>		<i>Suggested use</i>
100P	High power 100% microwave power	For quick and thorough cooking such as meat and vegetables.
80P	Medium high power 80% microwave power	For medium express cooking, such as eggs, fish, rice and soup.
60P	Medium power 60% microwave power	For steaming food.
40P	Medium low power 40% microwave power	For defrosting food.
20P	Low power 20% microwave power	For keeping food warm.

Time setting

- When the Auto Cooking button **(6)** is pressed, the display will show a cooking time of 10 seconds. Each press of this button will increase the time by a further 10 seconds.
- Once the time reaches 5 minutes, each press will increase the time by 30 seconds. When 99 minutes and 60 seconds is reached, one more press will increase to the maximum time of 99 minutes and 99 seconds.
- When the Weight.Time.Temp button **(8)** is pressed, the display will show a cooking time of 99 minutes and 99 seconds. The second press will decrease the time to 99 minutes and 60 seconds. After this, each press of this button will decrease the time by 30 seconds.
- Once the time reaches 5 minutes, each press will decrease the time by 10 seconds.
- The minimum cooking time that can be set is 10 seconds.

Convection / Combination cooking

- Use the door release button to open the door of the microwave.
- Check that the turntable shaft, turntable ring assembly and glass tray are correctly assembled in the cavity.
- Place whatever you are cooking in the centre of the microwave cavity.
- Press the Stop.Clear button **(2)** once when the colon flashes on the LED display.
- Select the required cooking function, according to the table on the next page, by pressing the Convection Combi button **(4)**.
- You can then set the desired cooking temperature by pressing the Weight.Time.Temp button **(8)** to decrease and the Auto Cooking button **(6)** to increase.
- For defrosting the recommended temperature is 100 - 140°C. For baking the recommended temperature is 140 - 180°C. For cooking meat, the recommended temperature is 180 - 210°C.

IMPORTANT: In combination mode, the cooking temperature set cannot exceed 180°C as the oven cannot be heated to a higher temperature than this.

- Press the Instant Start button **(1)** to confirm.
- Set the required cooking time or preheating time. *In most cases the oven has to be preheated for about 15 minutes before placing food in the microwave in order to achieve best results.* Use the Weight.Time.Temp button **(8)** to decrease and the Auto Cooking button **(6)** to increase the cooking time.

IMPORTANT: Preheating is not recommended in combination programs. You should only preheat when using convection only.

- Close the microwave oven door and press the Instant Start button **(1)** to begin cooking. The LED display will count down to show the remaining cooking time.
- As the temperature is increasing, the relevant LED on the display will light to indicate the internal temperature. Once the oven has reached the set temperature, the numbers will go steady and the preheating process will be complete.

- If you turn the food during the cooking process, press the door release button to access the food. Close the door again and press the Instant Start button **(1)** to continue the cooking procedure.
- If you wish to remove the food before the preset time, you must press the Stop.Clear button **(2)** once to clear the preset program to avoid unintended operation during next use.
- At the end of the cooking time, the LED display will show “End” and 3 beeps will sound to prompt you to remove the food from the microwave. If you do not press the Stop.Clear button **(2)** once or open the door, the beep will sound every 3 minutes.
- **IMPORTANT:** *The inside of the microwave and the food that you have been cooking may be extremely hot. So care should be taken when removing items from the microwave. We would recommend that you use an oven glove.*
- After the food has been removed from the microwave, you should make sure that the door is closed.

Convection / Combination chart

<i>Cooking Program</i>	<i>Description</i>
C	Convection – The convection elements will be utilised during operation time. In this mode, hot air is circulated throughout the microwave cavity to brown and crisp foods quickly and evenly.
C1	Combination of convection and microwave cooking – The combination of these 2 methods produces juicy meats, as well as tender poultry with the right level of browning and crispness. Meats and poultry are best when cooked directly on the rack. A shallow dish can be placed below the food for gravy drips.
C2	Same as C1 but with more microwave cooking time which is suitable for cooking large size poultry. The microwaves are able to better penetrate the food to cook the inside more efficiently.

Convection cooking table

<i>Cooking task</i>	<i>Weight / size</i>	<i>Cooking temperature (°C)</i>	<i>Preheating</i>	<i>Cooking time (mins)</i>
Grilling poultry	1.5 kg	230	Yes	45
Making	20 cm	180	Yes	45

cakes	diameter			
Making cookies	25 pieces	180	Yes	20
Baking pizza	15 mm thickness	200	Yes	30

Grill / Combination cooking

- Use the door release button to open the door of the microwave.
- Check that the turntable shaft, turntable ring assembly and glass tray are correctly assembled in the cavity.
- Place whatever you are cooking in the centre of the microwave cavity.
- Press the Stop.Clear button once when the colon flashes on the LED display.
- Select the required grilling function, according to the table on the next page, by pressing the Grill.Combi button **(4)**.
- You can then set the desired cooking time by pressing the Weight.Time.Temp button **(8)** to decrease and the Auto Cooking button **(6)** to increase.
- Close the microwave oven door and press the Instant Start button **(1)** to begin cooking. The LED display will count down to show the remaining cooking time.

IMPORTANT: It is not necessary to preheat the oven for grill cooking.

- If you turn the food during the cooking process, press the door release button to access the food. Close the door again and press the Instant Start button **(1)** to continue the cooking procedure.
- If you wish to remove the food before the preset time, you must press the Stop.Clear button **(2)** once to clear the preset program to avoid unintended operation during next use.
- At the end of the cooking time, the LED display will show "End" and 3 beeps will sound to prompt you to remove the food from the microwave. If you do not press the Stop.Clear button **(2)** once or open the door, the beep will sound every 3 minutes.
- ***IMPORTANT: The inside of the microwave and the food that you have been cooking may be extremely hot. So care should be***

taken when removing items from the microwave. We would recommend that you use an oven glove.

- After the food has been removed from the microwave, you should make sure that the door is closed.

Grill function chart

Grill function	Suggested use
G	The grill heating element only will be utilised during operation time. Ideally suited for grilling thin meats or pork, sausage and chicken wings as good browning can be obtained.
G1	Combination of grill and microwave cooking. This utilises the properties of microwave penetration so thick food is ideally suited to this function. The centre of the food can be cooked well and a brown crust obtained by the grill.
G2	Same as C1 but a longer working time.

Auto defrost

- Use the door release button to open the door of the microwave.
- Check that the turntable shaft, turntable ring assembly and glass tray are correctly assembled in the cavity.
- Place whatever you are defrosting in the centre of the microwave cavity.
- Press the Stop.Clear button **(2)** once when the colon flashes on the LED display.
- Select the required defrost function by pressing the Auto Defrost button **(7)**.
- Press the Instant Start button **(1)** to confirm.
- You can then set the weight of the food by pressing the Weight.Time.Temp button **(8)** to decrease and the Auto Cooking button **(6)** to increase. The microwave will determine the appropriate length of defrosting time according to the program and weight selected.
- Close the microwave oven door and press the Instant Start button **(1)** to begin cooking. The LED display will count down to show the remaining cooking time.

- Half way through the defrosting process a beep will sound 3 times to prompt you to turn the food over. Open the door and turn the food over, shielding the warm portion. Close the door again and press the Instant Start button **(1)** to continue defrosting. If you do not turn the food, the defrosting cycle will continue until the end of the countdown time.
- If you wish to remove the food before the preset time, you must press the Stop.Clear button **(2)** once to clear the preset program to avoid unintended operation during next use.
- At the end of the cooking time, the LED display will show “End” and 3 beeps will sound to prompt you to remove the food from the microwave. If you do not press the Stop.Clear button **(2)** once or open the door, the beep will sound every 3 minutes.
- After the food has been removed from the microwave, you should make sure that the door is closed.

Defrost program chart

<i>Defrost program</i>	<i>Weight options (kg)</i>	<i>Suggested use</i>
D1	2.0, 1.8, 1.6, 1.4, 1.2, 1.0, 0.9, 0.8, 0.7, 0.6, 0.5, 0.4, 0.3, 0.2, 0.1	For defrosting meat with a weight range between 0.1 kg and 2.0 kg.
D2	3.0, 2.8, 2.6, 2.4, 2.2, 2.0, 1.8, 1.6, 1.4, 1.2, 1.0, 0.8, 0.6, 0.4, 0.2	For defrosting poultry with a weight range between 0.2 kg to 3.0 kg.
D3	0.9, 0.8, 0.7, 0.6, 0.5, 0.4, 0.3, 0.2, 0.1	For defrosting seafood with a weight range between 0.1 kg to 0.9 kg.

Defrost guide

<i>Food</i>	<i>Recommended instructions</i>
Steaks / chops	<ul style="list-style-type: none"> ○ Shield the thin end of the chops or steaks with foil. ○ Position the food with thinner parts in the centre in a single layer on a shallow dish. If pieces are stuck together, try to separate as soon as possible. ○ When the microwave beeps, you should turn the food over, rearrange and shield the defrosted portions. ○ Press the Instant Start button to continue defrosting. ○ After the defrost time, stand the food covered with aluminium foil for 5-15 minutes.
Minced beef	<ul style="list-style-type: none"> ○ Place the frozen minced beef on a shallow dish and shield the edges. ○ When the microwave beeps, you should turn the food over. Remove the defrosted portions and shield the remaining edges with foil strips. ○ Press the Instant Start button to continue defrosting. ○ After the defrost time, stand the food covered with

	aluminium foil for 5-15 minutes.
Roast meat (Beef /Pork/ Lamb)	<ul style="list-style-type: none"> ○ Shield the edges with foil strips. ○ Place the joint with the lean side facing upwards (if possible) on a shallow dish. ○ When the microwave beeps, you should turn the food over and shield the defrosted portions. ○ Press the Instant Start button to continue defrosting. ○ After the defrost time, stand the food covered with aluminium foil 10-30 minutes.
Poultry	<ul style="list-style-type: none"> ○ Remove from original wrapper and shield the wing and leg tips with foil. ○ Place the breast side down on a shallow dish. ○ When the microwave beeps, you should turn the food over and shield the defrosted portions. ○ Press the Instant Start button to continue defrosting. ○ After the defrost time, stand the food covered with aluminium foil for 15-30 minutes. ○ After standing run under cold water to remove giblets if necessary.
Chicken pieces (wings and drumstick)	<ul style="list-style-type: none"> ○ Shield the exposed bone with foil. ○ Place the chicken pieces on a shallow dish. ○ When the microwave beeps, you should turn the food over, rearrange and shield the defrosted portions. ○ Press the Instant Start button to continue defrosting. ○ After the defrost time, stand the food covered with aluminium foil for 5-30 minutes.

Auto Cooking

The oven has a default cooking menu for simple operation. You should choose the appropriate menu according to the food type and weight. Please refer to the table below when making your selection as choosing the incorrect menu can largely influence the result.

- Use the door release button to open the door of the microwave.
- Check that the turntable shaft, turntable ring assembly and glass tray are correctly assembled in the cavity.
- Place whatever you are cooking in the centre of the microwave cavity.
- Press the Stop.Clear button **(2)** once when the colon flashes on the LED display.
- Select the required auto menu by pressing the Auto Cooking button **(6)**.
- You can then set the appropriate weight of the food using the Weight.Time.Temp button **(8)** to decrease and the Auto Cooking button **(6)** to increase.

- Close the microwave oven door and press the Instant Start button **(1)** to begin cooking. The LED display will count down to show the remaining cooking time.
- If you wish to remove the food before the preset time, you must press the Stop.Clear button **(2)** once to clear the preset program to avoid unintended operation during next use.
- At the end of the cooking time, the LED display will show “End” and 3 beeps will sound to prompt you to remove the food from the microwave. If you do not press the Stop.Clear button **(2)** once or open the door, the beep will sound every 3 minutes.
- **IMPORTANT:** *The inside of the microwave and the food that you have been cooking may be extremely hot. So care should be taken when removing items from the microwave. We would recommend that you use an oven glove.*
- After the food has been removed from the microwave, you should make sure that the door is closed.

Auto cooking chart

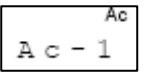
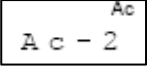
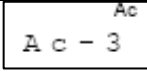
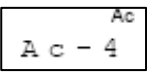
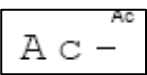
Display	Category	Directions
	Rice / Pasta	<ul style="list-style-type: none"> ○ Wash the rice or pasta and soak for 30 minutes. Place the rice or pasta in a deep and large bowl. ○ For 100g of rice use 180ml water, for 200g use 330ml, for 300g use 480ml and cover the bowl. ○ For 100g of pasta, use 300ml water, for 200g use 600ml, for 300g use 900ml and do not cover. ○ After cooking the rice, stand covered for 5 minutes or until the water is absorbed. ○ While cooking the pasta, stir several times. After cooking, stand for 1 or 2 minutes.
	Fresh vegetables	<ul style="list-style-type: none"> ○ Place 0.2-0.8 kg vegetables in a microwave-safe bowl. Add water and cover with wrap. ○ After cooking, stir and allow to stand. Add water according to the vegetable quantity e.g. for 0.2-0.4kg add 2 tablespoons and for 0.5-0.8kg add 4 tablespoons.
	Frozen vegetables	<ul style="list-style-type: none"> ○ Same directions as fresh vegetables.
	Popcorn	<ul style="list-style-type: none"> ○ Suitable for popping a bag of corn weighing 85-100g. When the popping speed has decreased to once per 1-2 seconds you should press the Stop.Clear button (2) to stop the popping process.
	Beverage	<ul style="list-style-type: none"> ○ Suitable for heating a cup of 250ml or 500ml liquid. The liquid temperature should be about 5-10°C before heating. Use a big mouthed cup and do not seal.

<div style="border: 1px solid black; padding: 2px; text-align: center;"> <small>Ac</small> A c - 6 </div>	Potato	<ul style="list-style-type: none"> ○ Suitable for cooking a jacket potato. Choose medium sized potatoes of about 200g in weight. You can use up to 0.45-0.65kg of potatoes. ○ Place the potatoes on a large dish and cover the dish with a thin film to prevent water loss, turning the potatoes halfway through.
<div style="border: 1px solid black; padding: 2px; text-align: center;"> <small>Ac</small> A c - 7 </div>	Pizza	<ul style="list-style-type: none"> ○ Warm a piece of chilled pizza weighing about 0.15kg.
<div style="border: 1px solid black; padding: 2px; text-align: center;"> <small>Ac</small> A c - 8 </div>	Fish	<ul style="list-style-type: none"> ○ Suitable for steaming a fish of 0.45kg. After the fish is washed and scales are removed, make slits on the skin of the fish. ○ Put the fish on a shallow dish of 22-27 cm diameter and sprinkle lightly with some ingredients. After cooking, stand for 2 minutes.

- Please note that results may vary depending on the initial temperature of the food being cooked. The cooking times of the auto menus are based on the food being at room temperature (20-25°C).
- The temperature, weight and shape of the food will largely influence the cooking result. If any deviation has been found, you can adjust the cooking time for best results.

Delay start function

If you do not wish for the cooking process to be started immediately, you can preset the cooking function and time and the microwave will begin at your set time.

- Use the door release button to open the door of the microwave.
- Check that the turntable shaft, turntable ring assembly and glass tray are correctly assembled in the cavity.
- Place whatever you are cooking in the centre of the microwave cavity.
- Press the Stop.Clear button **(2)** once when the colon flashes on the LED display.
- Select the required microwave power by pressing the microwave power button **(5)**.
- You can then set the desired cooking time by pressing the Weight.Time.Temp button **(8)** to decrease and the Auto Cooking button **(6)** to increase.
- Then hold the Preset.Clock button **(3)** for 3 seconds until a short beep is heard. Set the time you would like the microwave oven to start cooking at.

- Use the Weight.Time.Temp button **(8)** and Auto Cooking button **(6)** to set the hours. Press the Preset.Clock button **(3)** again.
- Use the Weight.Time.Temp button **(8)** and Auto Cooking button **(6)** to then set the minutes. Press the Preset.Clock button **(3)** to confirm the delayed start time.
- Now the program has been activated and the microwave will turn on accordingly. You can check the preset time by pressing the Preset.Clock button **(3)**.
- Close the microwave oven door.
- If you wish to remove the food before the preset time, you must press the Stop.Clear button **(2)** once to clear the preset program to avoid unintended operation during next use.
- At the end of the cooking time, the LED display will show "End" and 3 beeps will sound to prompt you to remove the food from the microwave. If you do not press the Stop.Clear button **(2)** once or open the door, the beep will sound every 3 minutes.
- ***IMPORTANT:*** *The inside of the microwave and the food that you have been cooking may be extremely hot. So care should be taken when removing items from the microwave. We would recommend that you use an oven glove.*
- After the food has been removed from the microwave, you should make sure that the door is closed.

Multi-sequence cooking

To obtain the best cooking result, some recipes require different cooking functions and times. You can program the microwave to follow one program after another.

- Use the door release button to open the door of the microwave.
- Check that the turntable shaft, turntable ring assembly and glass tray are correctly assembled in the cavity.
- Place whatever you are cooking in the centre of the microwave cavity.
- Press the Stop.Clear button **(2)** once when the colon flashes on the LED display.

- Select the first required function by pressing the microwave power button **(5)** or the Convection Combi / Grill.Combi button **(4)**.
- Use the Weight.Time.Temp button **(8)** and the Auto Cooking button **(6)** to set the desired cooking time for the first phase.
- Then select the second required function by pressing the microwave power button **(5)** or the Convection Combi / Grill.Combi button **(4)**.
- Use the Weight.Time.Temp button **(8)** and the Auto Cooking button **(6)** to set the desired cooking time for the second phase.
- ***A maximum of 4 phases can be set by following the above instructions.***
- Close the microwave oven door and press the Instant Start button **(1)** to begin cooking. The LED display will count down to show the remaining cooking time. When the first phase has finished, the second phase will begin automatically.
- If you wish to remove the food before the preset time, you must press the Stop.Clear button **(2)** once to clear the preset program to avoid unintended operation during next use.
- At the end of the cooking time, the LED display will show "End" and 3 beeps will sound to prompt you to remove the food from the microwave. If you do not press the Stop.Clear button **(2)** once or open the door, the beep will sound every 3 minutes.
- ***IMPORTANT:*** *The inside of the microwave and the food that you have been cooking may be extremely hot. So care should be taken when removing items from the microwave. We would recommend that you use an oven glove.*
- After the food has been removed from the microwave, you should make sure that the door is closed.

Safety lock

- When the microwave is not heating, it is possible to switch on the safety lock.
- Press and hold down the Stop.Clear button **(2)** for 3 seconds until the LED display shows "OFF".
- Until the safety lock is switched off, all buttons on the microwave will be disabled.

- To switch off the safety lock, press and hold down the Stop.Clear button **(2)** for 3 seconds until the LED display shows " : ".

Microwave cooking guidelines

- If you are heating liquid in the microwave, then you must also place a teaspoon in the container. This will ensure that the liquid does not boil suddenly after being removed from the microwave cavity.
- This phenomenon is called "delayed boiling", this means that a liquid can be close to boiling point, even if there is no steam coming off the liquid or the liquid is not bubbling. If the liquid container is even gently shaken, then the liquid can without warning boil over or even spurt. This could **scald the end user**.
- If the food you are cooking has a skin or peel (e.g. sausages, tomatoes, potatoes etc), then you should pierce the skin or peel with a fork. This will ensure that if steam is created during the heating process, it can escape and the food will not burst.
- When heating baby food, the bottle or jar containing the food should **NEVER** have a top or lid on. After cooking, to ensure that the food has been heated uniformly, you should stir or shake the food. **IMPORTANT:** *You must check the temperature of the food before feeding it to a child.*
- When heating food in a microwave, it will transmit the heat to the container that the food is in or on. You should **ALWAYS** use oven gloves when removing items from the microwave.
- You should make sure that you do not cook food for too long or at too high a power level. This could cause certain areas of the food to dry out or even ignite.
- You should not use ceramic or porcelain crockery, or porous earthenware inside of your microwave. These dishes could absorb moisture from the food whilst it is cooking, which could cause pressure to build up and shatter the dish.
- If you are heating certain foods and any liquid, moisture will evaporate and condensation may occur. This does not indicate that the appliance is faulty and it can be particularly noticeable if the ambient temperature of the room is high.
- **IMPORTANT:** *Any condensation should be wiped up with a soft cloth as soon as you have finished using the microwave.*

- After the cooking time has completed, you should let the food stand for a few minutes. This is called “standing time” and will allow the heat generated by the microwave to spread evenly throughout the food.

Materials you can use for microwave cooking

<i>Material</i>	<i>Remarks</i>
Aluminium foil	To be used for shielding only. Small smooth pieces can be used to cover thin parts of meat or poultry to prevent overcooking. Arcing can occur if foil is too close to the cavity walls. The foil should be at least 2.5 cm away from the cavity walls.
Browning dish	Follow the manufacturer’s instructions. The bottom of the browning dish must be at least 5 mm thick above the turntable. Incorrect usage may cause the turntable to break.
Dinnerware	Microwave-safe only. Follow the manufacturer’s instructions. Do not use cracked or chipped dishes.
Glass jars	Always remove the lid. Use only to heat food until just warm. Most glass jars are not heat resistant and may break.
Glassware	Heat-resistant oven glassware only. Make sure there is no metallic trim. Do not use cracked or chipped dishes.
Oven cooking bags	Follow the manufacturer’s instructions. Do not close with a metal tie. Make slits in the bag to allow steam to escape.
Paper plates and cups	Use for short-term cooking/warming only. Do not leave the oven unattended whilst cooking.
Paper towels	Use to cover food for reheating and absorbing fat. Use under supervision and for short-term cooking only.
Parchment paper	Use as a cover to prevent splattering or as a wrap for steaming
Plastic	Microwave-safe only. Follow the manufacturer’s instructions. It should be labelled as “microwave safe”. Some plastic containers soften as the food inside gets hot. “Boiling bags” and tightly closed plastic bags should be slit, pierced or vented, as described by the package.
Plastic wrap	Microwave-safe only. Use to cover food during cooking to retain moisture. Do not allow the plastic wrap to touch the food.
Thermometers	Microwave-safe only. Meat and candy thermometers.
Wax paper	Use as a cover to prevent splattering and to retain moisture.

Materials you cannot use for microwave cooking

<i>Material</i>	<i>Remarks</i>
Aluminium tray	May cause arcing. Transfer food into a microwave-safe dish.
Food carton with metal handle	May cause arcing. Transfer food into a microwave-safe dish.
Metal or metal-trimmed utensils	Metal shields the food from microwave energy. The metal trim may cause arcing.
Metal twist ties	May cause arcing and could cause a fire in the oven.
Paper bags	May cause a fire in the oven.
Plastic foam	Plastic foam may melt or contaminate the liquid inside when exposed to a high temperature.
Wood	Wood will dry out when used in the microwave oven and may split or crack.

Utensils table

<i>Cookware</i>	<i>Microwave</i>	<i>Grill</i>	<i>Combination*</i>
Heat-resistant glass	Yes	Yes	Yes
Non heat-resistant glass	No	No	No
Heat-resistant ceramics	Yes	Yes	Yes
Microwave-safe plastic dish	Yes	No	No
Kitchen paper	Yes	No	No
Metal tray	No	Yes	No
Metal rack	No	Yes	No
Aluminium foil and foil containers	No	Yes	No

* Combination mode applies to microwave + grill and microwave + convection modes.



Cleaning operations must only be carried out when the oven is cool.

The appliance should be disconnected from your mains supply before commencing any cleaning process.

The appliance exterior

- You should wipe over the front of the appliance with a soft cloth and warm water mixed with a little washing up liquid.
- **DO NOT** use abrasive cleaners or sharp objects to clean the front surface of the microwave.

The appliance interior

- You should wipe over the inside of the appliance with a soft cloth and warm water mixed with a little washing up liquid.
- You should pay particular attention to the door seal and the surrounding area.
- **DO NOT** use abrasive cleaners or sharp objects to clean the inside of the microwave.

Turntable and turntable support

- The glass tray and turntable ring assembly should be removed from the microwave for cleaning purposes after each use.
- Clean the glass tray and turntable ring assembly in warm water mixed with a little washing up liquid.

General cleaning advice

- **IMPORTANT:** *Any condensation should be wiped up with a soft cloth as soon as you have finished using the microwave.*
- To remove odours from inside of the microwave, you should boil one cup of water mixed with several tablespoons of lemon juice inside of the cavity.
- The microwave should be thoroughly cleaned before it is operated for the first time and after each use. This will avoid residual food stuffs becoming baked on the oven cavity. After

residues have been baked on several times, they are far more difficult to remove.

- **Never** clean the oven surfaces by steam cleaning.
- If you use any form of oven cleaner on your appliance, then you must check with the manufacturer of the cleaner that it is suitable for use on your appliance.
- **Any damage that is caused to the appliance by a cleaning product will not be fixed by Baumatic free of charge, even if the appliance is within the guarantee period.**

Installation



The installation must be carried out by a suitably qualified person, in accordance with the current version of the following.

- ***UK Regulations and Safety Standards or their European Norm Replacements.***
- ***Building Regulations*** (issued by the Department of the Environment).
- ***Building Standards*** (issued by the Scottish Development Department).
- ***IEE Wiring Regulations.***
- ***Electricity At Work Regulations.***

Electrical connection



YOUR MICROWAVE IS INTENDED FOR FITTED AND PERMANENT INSTALLATION.

- Before connecting the appliance, make sure that the supply voltage marked on the rating plate corresponds with your mains supply voltage.
- We recommend that the appliance is connected by a qualified electrician, who is a member of the N.I.C.E.I.C. and who will comply with the I.E.E. and local regulations.
- ***WARNING: THIS APPLIANCE MUST BE EARTHED.***
- This appliance is supplied with a moulded plug, which must be connected to an earthed socket.

- If in future you need to change the fuse in this plug, then a 13 amp ASTA approved (BS 1362) fuse **must** be used.
- If the earthed socket is not accessible after the appliance is installed. Then the microwave must be wired into a 13 A double pole switched fused spur outlet, having 3 mm contact separation and placed in an easily accessible position adjacent to the appliance. The spur outlet must still be accessible even when your microwave is located in its housing.
- The wiring in the mains lead is coloured as follows:

Brown	Live
Blue	Neutral
Green and yellow	Earth

- As the colours of the wires in the appliance's mains lead may not correspond with the coloured markings identifying the terminals in your spur box, please proceed as follows:

The **brown wire** must be connected to the terminal marked "L" (live), or coloured **red**.

The **blue wire** must be connected to the terminal marked "N" (neutral), or coloured **black**.

The **green and yellow wire** must be connected to the terminal marked "E" (earth), or by the earth symbol, or coloured **green and yellow**.

- When the connection is completed, no stray strands or cut wire should be present. The cord clamp must be secured over the outer sheath.
- Broken or damaged power leads must only be replaced by a suitably qualified person. A power lead of a similar type must be used in replacement.



Before beginning to install your appliance, check that there is no sign of damage (on the inside or the outside of the microwave), and that there are no packing materials or accessories inside the cavity. Remove any protective film on the microwave.

Fitting the distance limiter

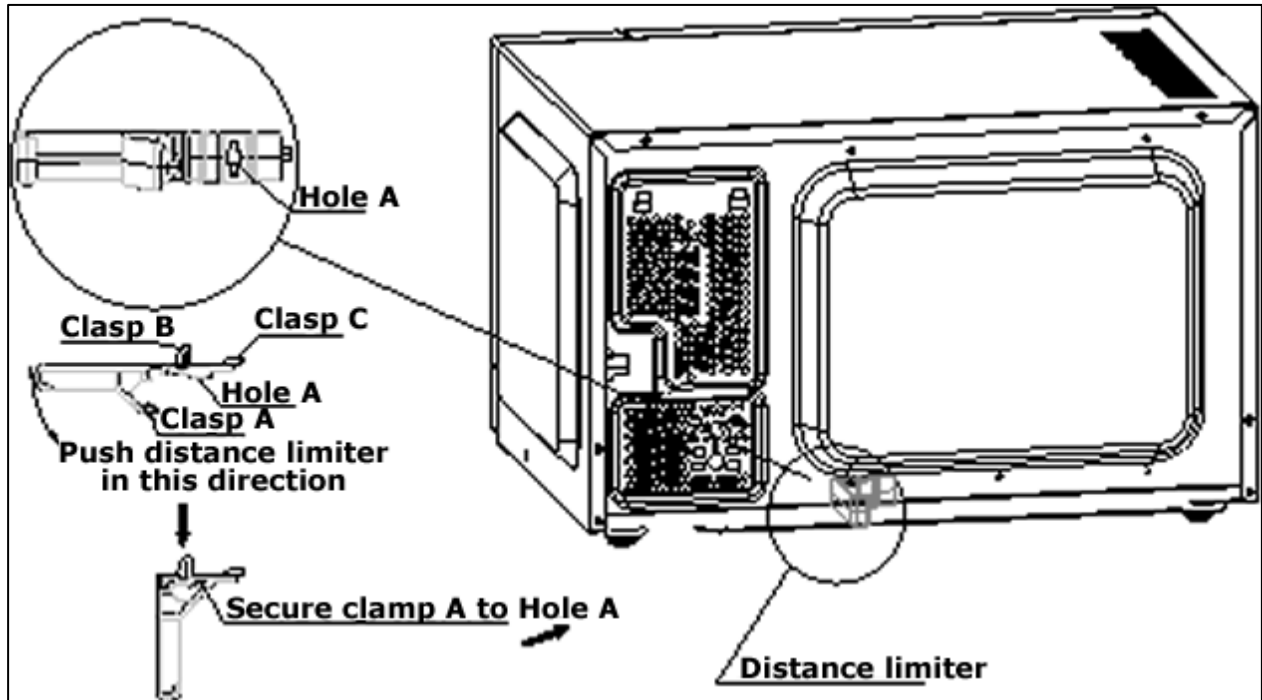

IMPORTANT: The distance limiter **MUST** be fitted to the appliance, to prevent it from being pushed up against the wall surface behind it.

- Push the distance limiter in the direction shown in the diagram above.
- Ensure that Clasp A is secured to Hole A.
- Insert Clasp B and Clasp C into their respective square holes.

Positioning

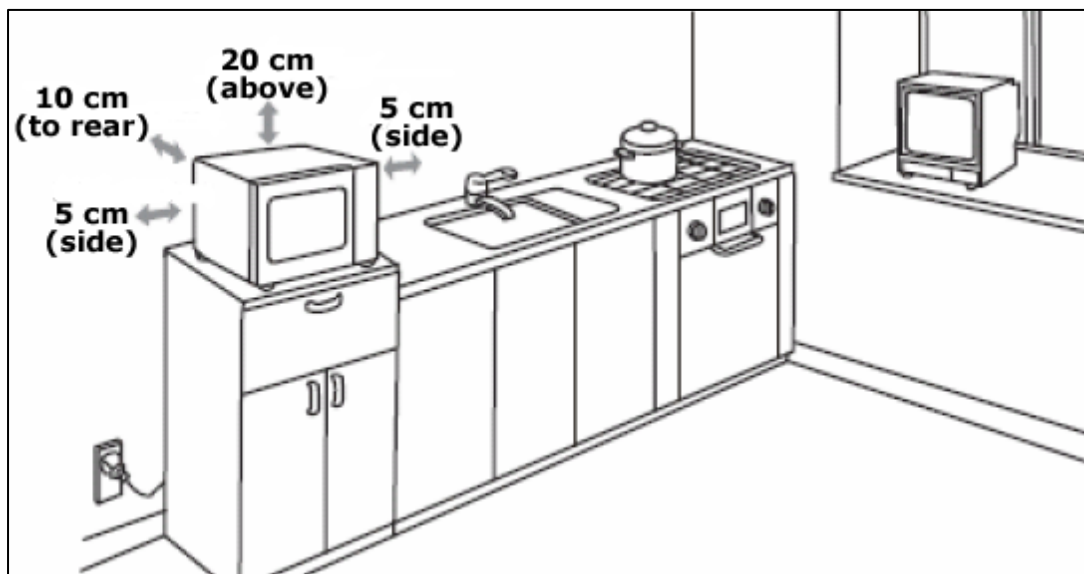

Troubleshooting

- ***The microwave will not switch on.***
 - * Check that the appliance has been connected to the mains supply correctly.
 - * Check that the fuse in the moulded plug has not blown.
 - * Check that the fuses in your fuse box have not blown.
 - * If fuses blow on a regular basis, then we would recommend that you consult with a qualified electrician.
 - * Check that there has not been a power cut.

- ***The microwave will not start cooking.***
 - * Check that the door is properly shut.
 - * Check that the door seal and surrounding area are clean.
 - * Check that you have pressed the Instant Start button.

- ***The turntable is not turning.***
 - * Check that the turntable shaft is connected to the drive motor correctly.
 - * Check that the ovenware is not larger than the turntable glass.
 - * Check that the food you are cooking does not extend beyond the turntable glass.
 - Check that there is nothing underneath the turntable that is preventing it from turning.

- ***The microwave does not switch off.***
 - * Isolate the microwave from your mains supply and then contact the Baumatic Customer Care Department.

- ***The interior light bulb is not working.***
 - * Call the Baumatic Customer Care Department. The interior light bulb can only be replaced by a trained service technician.

- ***My food is not cooking properly***
 - * Check that the power level and cooking time that you have set, is appropriate for the food that you are cooking.
 - * If you are cooking a double amount of food, then you will normally need to almost double the cooking time.
 - * If the food that you have placed in the cavity is colder than normal, then the power level and cooking time may need to be increased.

- ***I am getting condensation in my oven***
- * Steam and condensation are a natural by product of cooking in a microwave.
- * Do not leave food in the oven to cool after it has been cooked and the oven has been switched off.
- * Use a covered container, where practical, when cooking to reduce the amount of condensation that forms.
- * You should wipe over any condensation that has formed, as soon as the food has stopped cooking.



IMPORTANT: If your appliance appears not to be operating correctly, then you should disconnect it from your mains supply and then contact Baumatic Customer Care on telephone number (0118) 933 6911.

DO NOT ATTEMPT TO REPAIR THE APPLIANCE YOURSELF.

Please note that if an engineer is asked to attend whilst the product is under guarantee and finds that the problem is not the result of an appliance fault, then you may be liable for the cost of the call out charge.

The appliance must be accessible for the engineer to perform any necessary repair. If your appliance is installed in such a way that an engineer is concerned that damage will be caused to the appliance or your kitchen, then he will not complete a repair.

This includes situations where appliances have been tiled in, sealed in with sealant, have wooden obstructions placed in front of the appliance, like plinths. Or any installation other than the one specified by Baumatic Ltd. has been completed.

Please refer to the conditions of guarantee that appear on the warranty card that you receive with the appliance.

IMPORTANT: Baumatic Ltd. operates a policy of continuous improvement and reserves the right to adjust and modify its products without prior notification.

Baumatic consumables

- **BC001** Degreaser for Dishwashers (200g)
- **BC002** Descaler for Washing Machines and Dishwashers (200g)
- **BC003** Ceramic Hob Cleaner (250ml)
- **BC004** Oven Cleaner (250ml)
- **BC005** Stainless Steel Cleaner and Protector (250ml)
- **BC007** E-Cloth – General Purpose Cloth
- **BC008** Microwave Cover

To order a Baumatic consumable product please call 0123 5437 244 and quote the product code. You can also order online from eshop.baumatic.co.uk



United Kingdom

Baumatic Ltd.,
Baumatic Buildings,
6 Bennet Road,
Reading, Berkshire
RG2 0QX
United Kingdom

Sales Telephone

(0118) 933 6900

Sales Fax

(0118) 931 0035

Customer Care Telephone

(0118) 933 6911

Customer Care Fax

(0118) 986 9124

Spares Telephone

(01235) 437244

Advice Line Telephone

(0118) 933 6933

E-mail:

sales@baumatic.co.uk
customercare@baumatic.co.uk
spares@baumatic.co.uk
technical@baumatic.co.uk

Website:

www.baumatic.co.uk

Facebook:

www.facebook.com/baumatic.uk

Republic of Ireland

Service Telephone

1-890 812 724

Spares Telephone

091 756 771

Czech Republic

Baumatic CR spol s.r.o.
Lipová 665
460 01 Liberec 4
Czech Republic

+420 483 577 200

www.baumatic.cz

Slovakia

Baumatic Slovakia, s.r.o.
Galvániho 7/D
Slovakia

+421 255 640 618

Germany

Baumatic GmbH
Bachstr.10-12
D-32 257 Bünde
Germany

+49 (0) 5223 99408 0

www.baumatic.de

Italy

Baumatic Italia S.R.L.
Via Galvani N.3
35011 Campodarsego (PD)

+3904 9920 2297

www.baumatic.it

Holland

Baumatic Benelux B.V.
Dukdalfweg 15d
1332 BH ALMERE
Nederland

+31(0)36 549 1553

www.baumatic.nl

