

**BZ550W**  
**Under counter**  
**freezer**

**INSTRUCTION MANUAL**

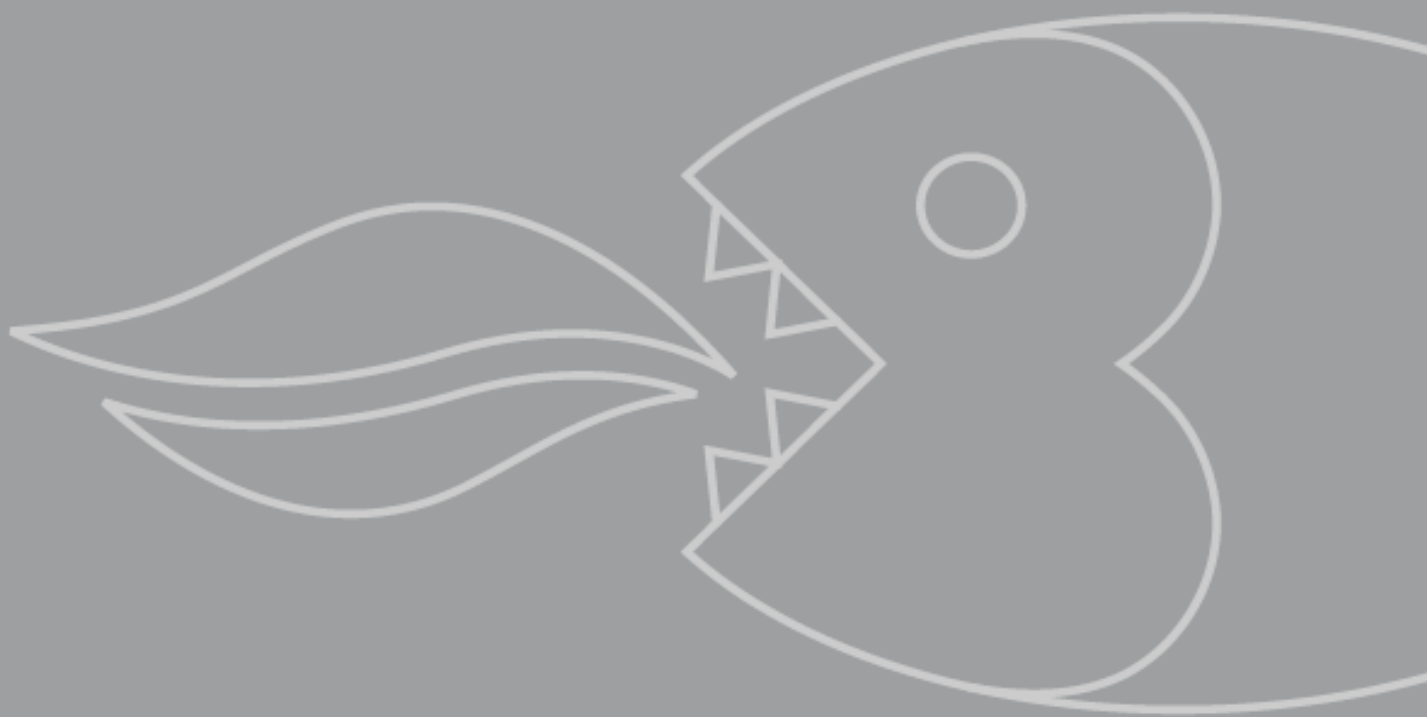

# USER MANUAL FOR YOUR BAUMATIC

## BZ550W Under counter freezer



***NOTE: This User Instruction Manual contains important information, including safety & installation points, which will enable you to get the most out of your appliance. Please keep it in a safe place so that it is easily available for future reference, for you or any person not familiar with the operation of the appliance.***

# Contents

<b>Environmental note</b>	4
<b>Important safety information</b>	5 - 7
<b>Specifications of your freezer</b>	7
<b>Description of the appliance</b>	8
<b>Using your Baumatic freezer</b>	9-10
Before switching on	9
During first use	9
Switching on the appliance and setting the thermostat	10
<b>The **** freezer</b>	11-13
Freezing fresh food	11
Storing commercially frozen food	12
Defrosting frozen food	12
Making ice cubes	12
Normal operating noises	13
<b>Cleaning and maintenance</b>	13-15
Defrosting the freezer	14-15
Prolonged OFF periods	15
<b>Installation</b>	15-19
Electrical connection	15-16
Positioning	16-17
Levelling the appliance	17
Reversing the door	17-19
<b>Troubleshooting</b>	20-21
<b>Baumatic consumables</b>	22
<b>Technical data</b>	23
<b>Contact details</b>	24

## Environmental note

***Note: Before discarding an old appliance, switch off and disconnect it from the power supply. Cut off and render any plug useless. Cut the cable off directly behind the appliance to prevent misuse. This should be undertaken by a competent person. Disable the door lock to make sure that children cannot get stuck inside the appliance.***

**This appliance is marked according to the European directive 2002/96/EC on Waste electrical and Electronic Equipment (WEEE). By ensuring this product is disposed of correctly, you will help prevent potential negative consequences for the environment and human health, which could otherwise be caused by inappropriate waste handling of this product.**

The symbol  on the product, or on the documents accompanying the product, indicates that this appliance may not be treated as household waste. Instead it shall be handed over to the applicable collection point for the recycling of electrical and electronic equipment.

**Disposal must be carried out in accordance with local environmental regulations for waste disposal.**

**For more detailed information about treatment, recovery and recycling of this product, please contact your local city office, your household waste disposal service or the shop where you purchased the product.**



- The packaging materials that Baumatic uses are environmentally friendly and can be recycled.
- Please discard all packaging material with due regard for the environment.

## Important safety information



Your safety is of the utmost importance to Baumatic. Please make sure that you read this instruction booklet **before** attempting to install or use the appliance. If you are unsure of any of the information contained in this booklet, please contact the Baumatic Advice Line.

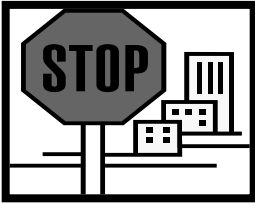

**IMPORTANT:** Any installation work must be carried out by a qualified electrician or competent person.

### Use of the appliance

- Your appliance is only designed to be used in the home. It is suitable for storing food that needs to be kept frozen. If it is used for any other purpose or it is not used correctly, then Baumatic Ltd. will accept no liability for any damage that is caused.



- Altering the specification of the appliance must not be attempted for reasons of safety.

### Before using your appliance

- Check the appliance for any signs of transport damage. If you notice any damage, then you should not connect your appliance to your mains supply and should contact your retailer.

### Refrigerant

- Your appliance contains R600a refrigerant, which is a natural gas that does not contain CFCs that can damage the environment. However it is a flammable substance, therefore care should be taken:
  - During the transportation and installation of the appliance, make sure that the refrigeration pipework does not get damaged.
  - If it does become damaged then sources of ignition and open flames should be avoided. Also the room that the appliance is situated in should be thoroughly ventilated.

- Do not place any objects on top of the appliance, as this may damage the table top.



### Child safety

- Packaging material should be kept away from children.
- Children should not be allowed to touch the controls or play with the appliance.



### General safety

- Do not pull on the power supply cable to remove the plug from your mains supply socket.
- Do not pull out or insert the plug with wet hands.
- Do not attempt to use your appliance outdoors or any place where it is likely to come into contact with the elements.
- Before cleaning the appliance or performing maintenance work, ensure that the appliance has been disconnected from your mains supply.
- Never allow the back coils of the appliance to come into contact with the wall surface.
- Always ensure that the location where you are installing your appliance is free of stored items such as papers and other flammable materials.
- Never block the ventilation openings of the appliance, either on the inside or its exterior.
- It is vital to keep your appliance well ventilated, so that there is proper air flow between the bottom of the unit and the plinth/kick plate which it is sitting on.

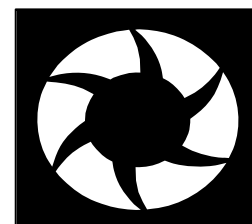
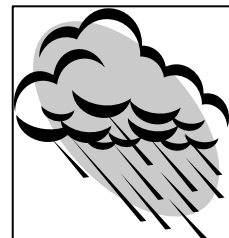

- Do not place electrical devices inside of the appliance, such as mixers or ice cream makers.

## Service

You should not attempt to repair the appliance yourself, as this could cause injury or a more serious malfunction. If you require a service call then please contact the Baumatic Customer Care Department.

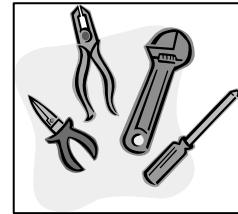

## Specifications of your freezer

- Freezer gross capacity: 95 litres
- Freezer net capacity: 83 litres
- Adjustable thermostat
- \*\*\*\* star freezer
- 3 x Transparent freezer drawers
- Ice-cube tray
- Adjustable feet
- Reversible door
- Manual defrost

## Dimensions of appliance

Height: 845 mm  
Width: 553 mm  
Depth: 574 mm

## Energy efficiency class

Energy class: A+

\* Please refer to the installation instructions for more specific information on the size of aperture that you will require.

***IMPORTANT:*** When you install your appliance it is important to bear in mind its climatic rating.

In order to find out the climatic rating of your appliance, you should check the rating plate. The rating plate is located behind the lower freezer drawer. You will need to open the door of your appliance and remove the lower freezer drawer to be able to find it. The rating plate will indicate the ambient temperature range that your appliance will function correctly within.

## Description of the appliance

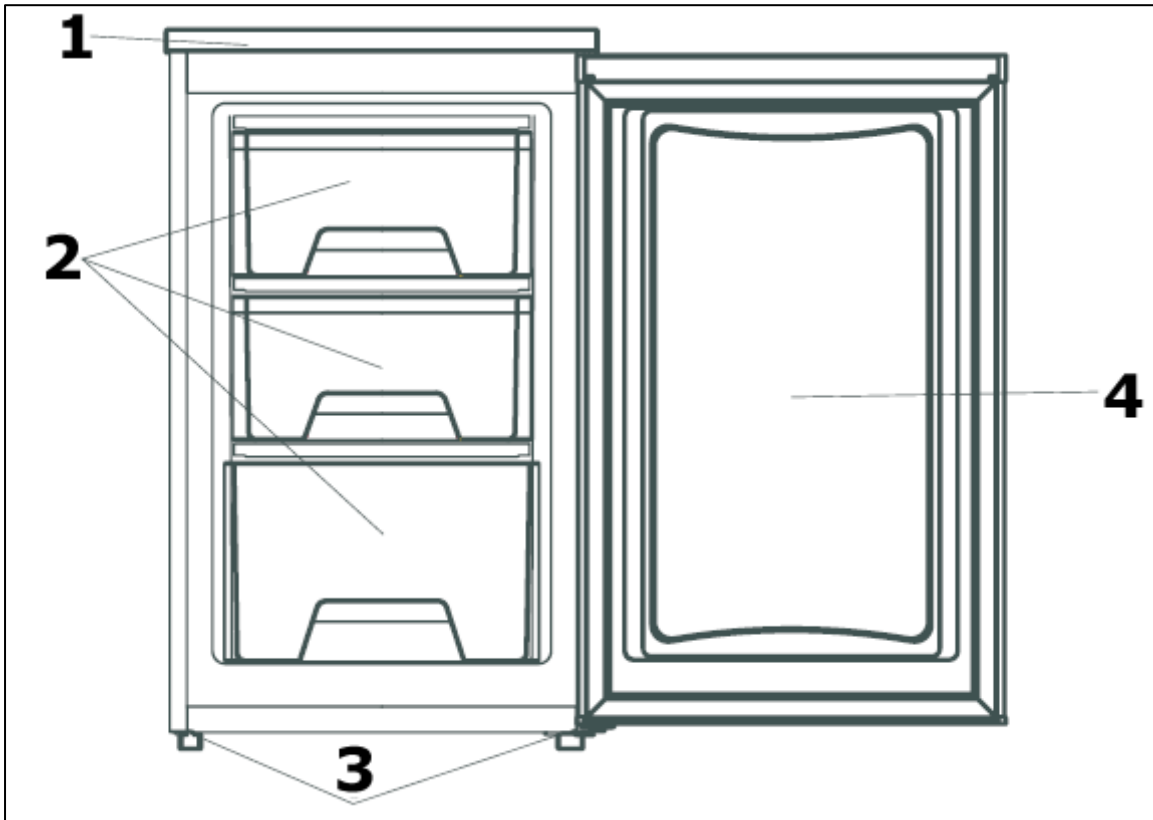

- 1) Top cover
- 2) Freezer drawers
- 3) Refrigerator feet / levelling foot
- 4) Freezer door



## Using your Baumatic freezer

### Before switching on

- Make sure that it has been installed by a suitably qualified person, as per the information contained in Baumatic's installation instructions.
- After delivery, wait for eight hours before connecting the appliance to your mains supply. This will allow any refrigerant gasses that may have been disturbed during the transportation process to settle.
- The outside of the appliance and the removable accessories contained within it, should be cleaned with a solution of liquid detergent and water.
- The interior of the appliance should be cleaned with a solution of sodium bicarbonate dissolved in lukewarm water. The interior and accessories should be thoroughly dried, after the cleaning process has been completed.
- There can be an odour when you first switch on the appliance. It will lessen as the appliance starts to cool.

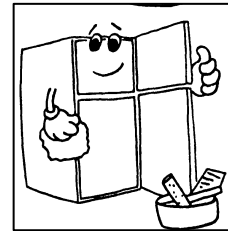

### During first use

- With dry hands, connect your appliance to your mains supply. Set the thermostat control knob to position <4> for a 24 - 48 hour period, before positioning it to the normal setting of between <2> and <3>.
- When you first switch on the appliance, the compressor will run more frequently for approximately 24 - 48 hours.
- During this period of time, you should try not to open the door frequently or place a large amount of food within the appliance.
- If the unit is switched off or unplugged, you must allow at least 5 minutes before restarting the appliance on the thermostat or reconnecting it to your mains supply.

## Switching on the appliance and setting the thermostat

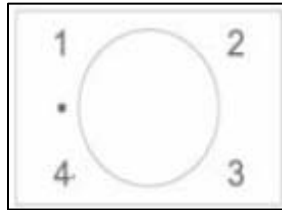

- You switch on your appliance by connecting it to your mains supply and setting the thermostat. The thermostat dial is located by opening the door of the freezer and looking behind the freezer drawers.
- The thermostat automatically regulates the temperature inside the fridge. The temperature is affected by the number that the thermostat dial is set to.
- The black dot position means that the appliance will not cool.
- Position <1> will give you a higher temperature inside the freezer.
- Position <4> will give you a lower temperature inside the freezer.
- Ideally the thermostat dial should be set to a position between <2> and <3>.
- The freezer can maintain a temperature of - 18 degrees centigrade and lower.
- **IMPORTANT:** *The ambient temperature of the room, the temperature of food and the amount of food that has been placed in the freezer and how often the door is opened, will all affect the temperature being maintained by the appliance.*

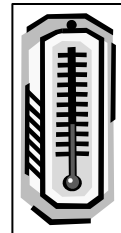

- On the maximum setting (position <4>), your freezer will work harder to maintain a lower temperature and will increase the energy usage. There is no need to run your appliance on setting <4> for prolonged periods.

## The \*\*\*\* freezer

The freezer is suitable for storing and freezing food.

- The freezer temperature must have already reached -18 degrees centigrade (or lower) before you attempt to store food that is already frozen or freezing fresh food.
- The freezer compartment is only able to freeze a certain quantity of fresh food at one time. The maximum amount of fresh food (in kilograms) that can be frozen in a 24 hour period is 4 kg.
- Warm food should be allowed to cool down before you attempt to freeze it. If you place warm food in the freezer compartment, then the increased humidity will cause quicker ice formation and increase the amount of power that the appliance uses.
- The guidance of the food manufacturer should be followed, in regard to the maximum storage time.
- Thawed foods must not be frozen for a second time.
- Do not open the freezer door too often or leave the door open for long periods of time, as this will increase the temperature inside of the appliance and will increase the energy usage.

### Freezing fresh food

- To freeze the maximum quantity of fresh food specified above, you should turn the thermostat dial to position <4>, 3 hours prior to attempting freezing.
- For smaller quantities of fresh food, you should turn the thermostat dial to position <4>, approximately 1 hour prior to attempting freezing.
- Fresh food should be packed into airtight containers or packaging. This will help to make sure that the food doesn't dry out or lose its flavour. It will also ensure that flavour does not transfer from other foods.
- Do not allow fresh food to touch items that are already frozen.
- After 24 hours you should check that the fresh food is satisfactorily frozen. If it is then the thermostat dial should be turned down to its normal setting (between <2> and <3>).

## Storing commercially frozen food

- The storage time and recommended temperature for storing commercially frozen foods are indicated on the packaging.
- Always follow the manufacturer's instructions for storage and use of frozen food.
- When shopping, be careful to choose food which is adequately packed and is provided with complete storage instructions. It should have been stored in a freezer where the temperature does not rise above  $-18^{\circ}\text{C}$ .
- Do not buy packages of food that are covered with frost. This could indicate that the package has thawed at least once before.
- Take care that your frozen food packages do not start to thaw before you place them in your freezer. This will shorten the length of time that you can safely store the food for.

## Defrosting frozen food

- Partially thawed or defrosted foods should be used as soon as possible.
- Cold air preserves the food but it does not destroy the micro organisms which rapidly activate themselves after defrosting and make foods perishable.
- Partial defrosting reduces the nutritional value of food, especially fruits, vegetables and readymade meals.

## Making ice cubes

- Fill an ice cube tray with water and place it in the freezer compartment.
- After the water is completely frozen and turned to ice, you can twist the ice cube tray (as shown in the drawing below) to dispense the ice.

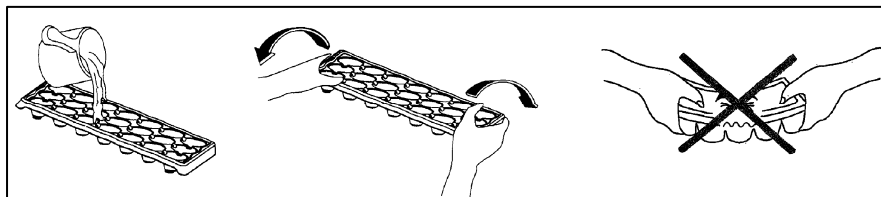

## Normal operating noises

### *Ice cracking noise*

- Can be caused by expansion and contraction within the freezer.

### *Short cracking noise*

- Can be heard when the thermostat turns the compressor on and off.

### *Compressor noise*

- There will be an operating noise when the compressor is running.
- After installation, the compressor may be noisier for a short period of time.

### *Bubbling and burbling sound*

- This noise is emitted as the coolant flows through the pipework within the freezer.

## Cleaning and maintenance

***WARNING: PLEASE ENSURE THAT YOUR APPLIANCE IS DISCONNECTED FROM YOUR MAINS SUPPLY BEFORE ATTEMPTING TO CLEAN IT.***

- Do not clean the appliance by pouring water onto it or spraying water over it.
- The freezer compartment should be cleaned periodically, using a solution of bicarbonate of soda and lukewarm water.
- Clean the accessories separately with soap and water. Do not clean them in a dishwasher.
- Do not use abrasive products, detergents or soaps.
- After washing the appliance, wipe over the area that you have cleaned with a damp cloth and then dry it thoroughly.
- When cleaning is complete, dry your hands and then reconnect the plug to your mains supply.

## Defrosting the freezer

*The frost in the freezer should be removed periodically. You can use a plastic scraper to keep down the amount of frost that builds.*

***IMPORTANT: The freezer should be defrosted at least twice a year. The number of times that you need to defrost it, will depend on the setting of your thermostat and how much food you freeze and store in the compartment.***

- The day before you defrost, turn the thermostat dial to position <4>, this will make sure that the food contained in the compartment is frozen properly.
- Whilst defrosting the appliance, the food should be removed from the compartment and wrapped in several layers of paper and stored in a cool place. The foods rise in temperature will shorten its storage life and therefore the food should be used within a relatively short period of time.
- ***DO NOT PLACE FOOD BACK IN THE FREEZER THAT HAS STARTED TO THAW.***
- Set the thermostat knob to position <0> and disconnect the appliance from your mains supply.
- Remove the drawers from the freezer and leave the door open. You can place a bowl of warm water inside the freezer to speed up the defrost process.
- You can use a sponge to mop up the defrost water that will run into the bottom of the freezer.
- ***IMPORTANT: You should place some old towels on the flooring that is immediately in front of the appliance. In case any defrost water comes out of the freezer and onto the floor.***
- Once all the ice that has built up has melted, then the inside of the freezer should be dried thoroughly. Failure to do this will result in immediate ice build when the appliance is turned back on.
- With dry hands, reconnect your appliance to your mains supply. Set the thermostat knob to position <4> for a 24 hour period, before returning it to the normal setting of between <2> and <3>.

- You should not attempt to freeze fresh food inside the freezer until this 24 hour time period has elapsed.
- Do not defrost the appliance with other electrical devices (e.g. hair dryer). Do not use sharp metal objects to remove the ice on the freezer, as this could cause damage to the refrigerant system.

### **Prolonged OFF periods**

If the freezer is not in use for a long period of time, you should:

- Disconnect the freezer from the mains supply.
- Clean and dry the inside as instructed on page 13.
- Leave the freezer door open to prevent any unpleasant smells from building up while the freezer is not in use.

## **Installation**

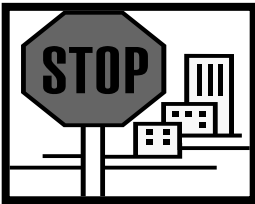

***IMPORTANT: Before installation and usage read all the instructions and make sure that the voltage (V) and the frequency (Hz) indicated on the rating plate are exactly the same as the voltage and frequency in your home. The rating plate can be found behind the bottom drawer in the freezer.***

The manufacturer declines all responsibility in the event of the installer failing to observe all the accident prevention regulations in force, which are necessary for normal use and the regular operation of the electric system.

### **Electrical connection**



***YOUR FREEZER IS INTENDED FOR FITTED AND PERMANENT INSTALLATION.***

We recommend that the appliance is connected by a qualified electrician, who is a member of the N.I.C.E.I.C. and who will comply with the I.E.E. and local regulations.

- Your freezer comes supplied with a 13 amp plug fitted. If in future you need to change the fuse in this plug, then a 13 amp ASTA approved (BS 1362) fuse **must** be used.
- The wiring in the mains lead is coloured as follows:

<b>Brown</b>	Live
<b>Blue</b>	Neutral
<b>Green and yellow</b>	Earth

- As the colours of the wires in the appliance's mains lead may not correspond with the coloured markings identifying the terminals in your spur box, please proceed as follows:

The **brown wire** must be connected to the terminal marked "L" (live), or coloured **red**.

The **blue wire** must be connected to the terminal marked "N" (neutral), or coloured **black**.

The **green and yellow wire** must be connected to the terminal marked "E" (earth), or by the earth symbol, or coloured **green and yellow**.

- When the connection is completed, no stray strands or cut wire should be present. The cord clamp must be secured over the outer sheath.

## Positioning

- It is advisable that your appliance is only installed in a location where the ambient temperature of the room, corresponds with the climate classification that is stated on the rating plate of your appliance. Your appliance may not function correctly if the ambient temperature falls outside of the following ranges.

<b><i>Climate classification</i></b>	<b><i>Appropriate ambient temperature</i></b>
SN	+10°C to +32°C
N	+16°C to +32°C
ST	+18°C to +38°C
T	+18°C to +43°C

- Positioning the appliance requires two people in order to avoid injuries or damage to the appliance.
- Your appliance should not be located in direct sunlight or exposed to continuous heat or extremes of temperature (e.g. next to a radiator or boiler). If this is not feasible, then you should install an insulation plate between the appliance and the adjacent heat source.
- You should check whether there is an electrical socket available, which will be accessible after your appliance is installed.



- Place the appliance flatly and firmly on a solid base. The appliance is fitted with adjustable feet on the front side, which can be used to level the appliance.
- To ensure proper ventilation for your freezer, there should be a gap of at least 2 cm on each side between walls, 2 cm between the back of the freezer and the wall and 3 cm between the top and the roof or ceiling.
- If you are placing another cooling appliance next door to this product, then there must be a gap of at least 2 cm between the appliances. This will help to prevent condensation from forming.
- Be sure to leave enough space for the opening of the door, to avoid damage to the appliance or personal injury.

### **Levelling the appliance**

- If the freezer is not levelled during installation, the doors may not close or seal properly causing cooling, frost or moisture problems.
- To level your freezer you may either turn the levelling foot clockwise to raise that side of the freezer or anti-clockwise to lower that side.

***WARNING: This process should be carried out by two people. While one person adjusts the levelling foot, the other should push against the top of the freezer to take some weight off the levelling foot. This makes it easier to adjust the levelling foot.***

### **Reversing the door**

***IMPORTANT: BEFORE COMMENCING THE DOOR REVERSAL PROCESS THE APPLIANCE MUST BE DISCONNECTED FROM YOUR MAINS SUPPLY.***

- We suggest that two people complete the door reversal process.
- We recommend that the door reversal process is done before the appliance is placed in its final position.
- If food is already stored inside of it, then this must all be removed before beginning the door reversal process.

### **TOOLS REQUIRED**

- Phillips style screwdriver
- Flat bladed screwdriver

1. Switch off the appliance at the socket and unplug it.

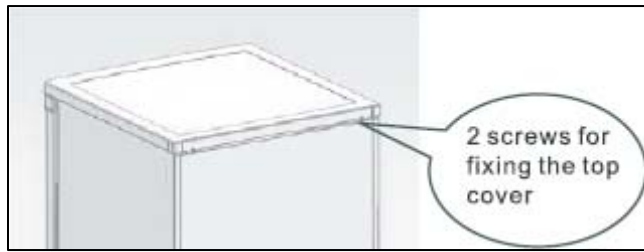

2. Unscrew the two screws on the top cover to remove it.

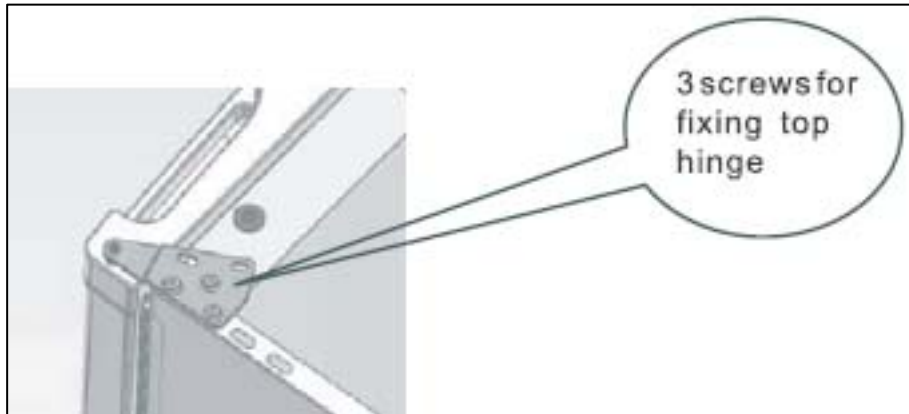

3. Unscrew the three screws on the top hinge.



4. Move the top hinge to the opposite side to its original position. Move the top hinge pin, shaft sheath and block piece to the opposite side to their original positions also.



5. Carefully remove the appliance door, placing it gently on a cushioned surface, so that it doesn't get damaged.

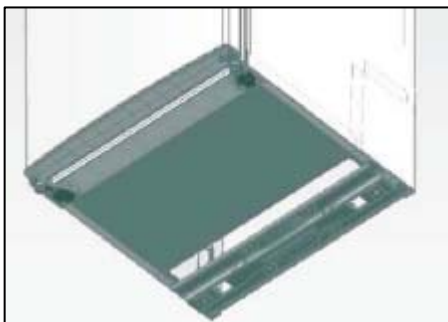

6. Carefully tilt the appliance to a 60° angle. Unscrew the three screws on the bottom hinge and move them to the opposite side from their original positions.

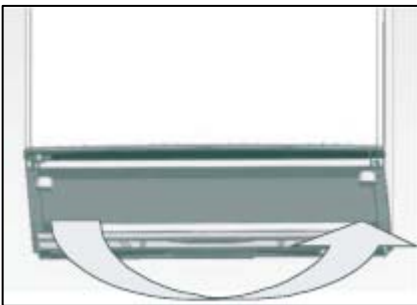

7. Move the adjustable foot to the opposite side from its original positions.

8. Reattach the door on the bottom hinge, making sure that it is correctly aligned, before re-fixing the top hinge and reinstalling the top cover.

***IMPORTANT: Check that the door opens and shuts correctly, without fouling, after you have completed the door reversal process.***



***After the door has been reversed, you should check the door seal of the appliance. The seal should not be creased or crushed; otherwise there will be a gap between it and the inside of the door.***

- o The seal must adhere properly all the way around the door.
- o If the seal is not adhering to the cabinet properly, then you should either:-
  1. Use a warm damp cloth and manipulate the seal until it does adhere to the cabinet properly, all the way around the door.

**OR**

2. Use a hair dryer on its lowest heat setting and lightly heat the areas of the door seal that are not adhering correctly. The heat will make the seal more pliable and this will allow you to manipulate the seal into the correct position.

***IMPORTANT: DO NOT HEAT THE DOOR SEAL ON ANYTHING BUT THE LOWEST HEAT SETTING, OR HEAT THE SEAL FOR A LONG PERIOD OF TIME. OTHERWISE DAMAGE MAY BE CAUSED TO THE DOOR SEAL, WHICH WOULD NOT BE RECTIFIED UNDER THE GUARANTEE FREE OF CHARGE.***

***IMPORTANT: WHEN YOU HAVE REVERSED THE DOOR OF THE APPLIANCE. AS YOU HAVE TILTED THE APPLIANCE BACKWARDS, YOU MUST WAIT FOR 8 HOURS BEFORE SWITCHING THE APPLIANCE BACK ON.***



**IMPORTANT:** *If your freezer appears not to be operating properly, before contacting the Baumatic Customer Care Department, please refer to the checklist below.*



***My freezer does not appear to be working/there is no power to my appliance.***

- Check that the plug is fully inserted into the power socket.
- Check that there is power to your mains supply (e.g. that there hasn't been a power cut or that the fuse hasn't blown).
- Check that the thermostat inside the appliance has not been turned to the off position.
- Check that your mains supply voltage, corresponds to the voltage stated on the rating plate of your appliance.



***My freezer appears to be performing poorly.***

- Check that the appliance isn't overloaded and that food hasn't been packed too tightly into it.
- The thermostat setting is too low; you should turn the thermostat up higher.
- Ensure that the door is closing properly and that the door has not been opened for a prolonged period in error.
- Ensure that there is adequate ventilation for your appliance.



***My freezer is noisy.***

- The refrigerant gas that circulates the pipework of the appliance may make a slight noise, even if the compressor is not running.
- If the noise worsens or the appliance gets louder than normal; check that it is levelled off correctly, that nothing is touching the rear of the fridge and that nothing placed inside the appliance is rattling.



***IMPORTANT: If your appliance appears not to be operating correctly, then you should disconnect it from your mains supply and then contact the Customer Care Department on telephone number (0118) 933 6911.***

***DO NOT ATTEMPT TO REPAIR THE APPLIANCE YOURSELF.***

Please note that if an engineer is asked to attend whilst the product is under guarantee and finds that the problem is not the result of an appliance fault, then you may be liable for the cost of the call out charge.

***The appliance must be accessible for the engineer to perform any necessary repair. If your appliance is installed in such a way that an engineer is concerned that damage will be caused to the appliance or your kitchen, then he will not complete a repair.***

***This includes situations where appliances have been tiled in, sealed in with sealant, have wooden obstructions placed in front of the appliance, like plinths. Or any installation other than the one specified by Baumatic Ltd. has been completed.***

Please refer to the conditions of guarantee that appear on the warranty card that you receive with the appliance.

***IMPORTANT: Baumatic Ltd. operates a policy of continuous improvement and reserves the right to adjust and modify its products without prior notification.***

## Baumatic Consumables

- **BC001** Degreaser for Dishwashers (200 g)
- **BC002** Descaler for Washing Machines and Dishwashers (200 g)
- **BC003** Ceramic Hob Cleaner (250 ml)
- **BC004** Oven Cleaner (250 ml)
- **BC005** Stainless Steel Cleaner and Protector (250 ml)
- **BC007** E-Cloth – General Purpose Cloth
- **BC008** Microwave Cover

To order a Baumatic consumable product please call 0123 5437 244 and quote the product code. You can also order online from [eshop.baumatic.co.uk](http://eshop.baumatic.co.uk)

## Technical Data

Manufacturer	BAUMATIC LTD
Model Number	BZ550W
Product Category	8 – Upright Freezer
Energy Efficiency Class <b>(1)</b>	A+
Annual Energy Consumption <b>(2)</b>	172 kWh
Storage Volume of Fridge Compartment	
Storage Volume of Freezer Compartment	83 litres
Star Rating	4
Frost Free Compartments	
Temperature Rise Time	10 hours
Freezing Capacity	4kg/24hr
Climate Class <b>(3)</b>	N
Noise Level	42 dB
Installation Type	Freestanding

**(1)** On a scale from A+++ (highest efficiency) to G (lowest efficiency).

**(2)** Annual energy consumption based on standard test results for 24 hours. The actual energy consumption will depend on how the appliance is used and where it is located.

**(3)** This appliance is intended to be used at an ambient temperature between "16°C" (lowest temperature) and "32°C" (highest temperature).



***United Kingdom***

Baumatic Ltd.,  
Baumatic Buildings,  
6 Bennet Road,  
Reading, Berkshire  
RG2 0QX  
United Kingdom

**Sales Telephone**

(0118) 933 6900

**Sales Fax**

(0118) 931 0035

**Customer Care Telephone**

(0118) 933 6911

**Customer Care Fax**

(0118) 986 9124

**Spares Telephone**

(01235) 437244

**Advice Line Telephone**

(0118) 933 6933

**E-mail:**

sales@baumatic.co.uk  
customercare@baumatic.co.uk  
spares@baumatic.co.uk  
technical@baumatic.co.uk

**Website:**

www.baumatic.co.uk

**Facebook:**

[www.facebook.com/baumatic.uk](http://www.facebook.com/baumatic.uk)

***Republic of Ireland***

**Service Telephone**

1-890 812 724

**Spares Telephone**

091 756 771

***Czech Republic***

Baumatic CR s.r.o.  
Lípová 665  
460 01 Liberec 4  
Czech Republic

+420 483 577 200

www.baumatic.cz

***Slovakia***

Baumatic Slovakia, s.r.o.  
Galvániho 7/D  
Slovakia

+421 255 640 618

***Germany***

Baumatic Gmbh  
Bachstr.10-12  
D-32257 Bünde  
Deutschland

+49 (0) 5223 99408 0

www.baumatic.de

***Italy***

Baumatic Italia S.R.L.  
Via Galvani N.3  
35011 Campodarsego (PD)

+3904 9920 2297

www.baumatic.it

***Holland***

Baumatic Benelux B.V.  
Dukdalfweg 15d  
1332 BH ALMERE  
Nederland

+31(0)36 549 1553

www.baumatic.nl









