

**BCD905SS**  
**90 cm Single cavity**  
**dual fuel cooker**

**INSTRUCTION MANUAL**



User Manual for your Baumatic

# BCD905SS

90 cm Single cavity dual fuel cooker



***NOTE: This User Instruction Manual contains important information, including safety & installation points, which will enable you to get the most out of your appliance. Please keep it in a safe place so that it is easily available for future reference; for you or any person not familiar with the operation of the appliance.***

GS 17/01/13

# Contents

<b>Environmental note</b>	4
<b>Important safety information</b>	5 – 8
<b>Specifications</b>	9 – 11
Dimensions	9
Specifications	9 - 10
Electrical details	10
Gas details	10
<b>Control panel</b>	11
<b>Timer (Minute minder)</b>	12
<b>Using the hob top</b>	12 - 14
Hob surface layout	12
Before first use	12
Lighting a burner	13
Optimum use of the burners	13
Hob guidelines	14
<b>Using the oven</b>	14 - 21
Before first use	14 - 15
Using the main oven	15
Cooking functions	16
Using the grill	17
Cooking guidelines	17
Warnings	18
Cooking guide for the main oven	18 - 19
Cooking tips for cakes and bread	20
Cooking tips for meat	21
<b>Cleaning and maintenance</b>	21 – 25
Cleaning the gas hob top	22
After each use	22
Cleaning the burners	23
Cleaning the oven	23
Replacing the oven bulb	24
Removing the oven door for cleaning	24
Removing the inner door glass for cleaning	25
Removing the side racks for cleaning	25
<b>Installation</b>	26 - 37
Positioning	26 - 27
Ventilation requirements	28 - 29
Securing the back-guard	29
Fitting the safety chain and hook	29 - 30
Electrical connection	31
Connecting the main supply cable	31 - 32
Gas connection	32
Gas safety (installation and use) regulations	33
Gas connection	33 - 34
Gas conversion to LPG	34 - 35
Minimum flow adjustment for hob gas taps	35 - 36
Gas tap replacement	36 - 37
<b>My appliance isn't working correctly</b>	37 – 39
<b>Baumatic consumables</b>	40
<b>Contact details</b>	41

**This appliance is marked according to the European directive 2002/96/EC on Waste electrical and Electronic Equipment (WEEE). By ensuring this product is disposed of correctly, you will help prevent potential negative consequences for the environment and human health, which could otherwise be caused by inappropriate waste handling of this product.**

The symbol  on the product, or on the documents accompanying the product, indicates that this appliance may not be treated as household waste. Instead it shall be handed over to the applicable collection point for the recycling of electrical and electronic equipment.

**Disposal must be carried out in accordance with local environmental regulations for waste disposal.**

**For more detailed information about treatment, recovery and recycling of this product, please contact your local city office, your household waste disposal service or the shop where you purchased the product.**



- The packaging materials that Baumatic uses are environmentally friendly and can be recycled.
- Please discard all packaging material with due regard for the environment.

## Important safety information



Your safety is of the utmost importance to Baumatic. Please make sure that you read this instruction booklet **before** attempting to install or use the appliance. If you are unsure of any of the information contained in this booklet, please contact the Baumatic Advice Line.

### General Information

- This appliance is designed for domestic household use and for the cooking of domestic foodstuffs.
- **IMPORTANT:** *The adjacent furniture and all materials used in the installation **must** be able to withstand a minimum temperature of 85°C above the ambient temperature of the room it is located in, whilst in use.*
- Certain types of vinyl or laminate kitchen furniture are particularly prone to heat damage or discolouration at temperatures below the guidelines given above.
- Any damage caused by the appliance being installed in contravention of this temperature limit, or by placing adjacent cabinet materials closer than 25 mm to the appliance, **will be the liability of the owner.**
- **IMPORTANT:** *Baumatic Ltd. **DO NOT** recommend that this appliance is installed on any type of marine vessel.*
- The use of this appliance for any other purpose or in any other environment without the express agreement of Baumatic Ltd. will invalidate any warranty or liability claim.
- Your new appliance is guaranteed against electrical or mechanical defects, subject to certain exclusions that are noted in Baumatic's Conditions Of Guarantee. The foregoing does not affect your statutory rights.
- **Repairs may only be carried out by Baumatic service engineers or their authorised service agents.**

## Warning and safety instructions

- This appliance complies with all current European safety legislation. Baumatic do wish to emphasise that this compliance does not remove the fact that the appliance surfaces ***will become hot during use and retain heat after operation.***

### Child Safety

- Baumatic strongly recommend that babies and young children are prevented from being near to the appliance and not allowed to touch the appliance ***at any time.*** During and after use, all surfaces will become hot.
- If it is necessary for younger family members to be in the kitchen, please ensure that they are kept under close supervision at all times.

### General Safety

- ✓ Make sure that you understand the controls before using the appliance.
- ✓ Check that all of the controls on the appliance are turned off after use.
- ✓ Always stand back when opening the oven door, this will allow heat to disperse.
- ✓ Take care when removing items from the oven, as the contents may be hot.
- ✓ Always keep the oven doors closed when the oven is not in use.
- ✓ Always follow the basic principles of food handling and hygiene; this will prevent the possibility of bacterial growth.
- ✓ Always keep ventilation slots clear of obstructions.
- ✓ Keep fingers away from the hinge areas when closing the door, otherwise you may trap them.
- ✓ Oven gloves should be used when placing food in the oven cavity and when removing it. Care should be taken to avoid direct contact with any of the elements in the appliance.
- ***DO NOT LEAVE THE APPLIANCE UNATTENDED WHILST IN USE.***

- **Do not** place heavy objects on the oven door or lean on the oven door when it is open, as this can cause damage to the oven door hinges. Nobody should be allowed to sit or stand on any part of the cooker.
- **Do not** store chemicals, food stuffs, pressurised containers in or on the cooker or in cabinets immediately above or next to the cooker.
- **Do not** heat up unopened food containers, as pressure can build up which may cause the container to burst.
- **Do not** place flammable or plastic items on or near the hob burners, these types of materials should also not be placed in the oven or the compartment below the oven.
- **Do not** leave heated oil or fat unattended, as this is a fire risk. You should not fill a deep fat frying pan more than one third full of fat or oil; you should also not use a lid.
- **Do not** allow fat or oil to build up in the oven trays, grill pan or oven base.
- **Do not** place pans or baking trays directly on the base of the oven cavity, or line it with aluminium foil.
- **Do not** grill food containing fat without using a grill trivet. The grill trivet should never be covered with aluminium foil.
- **Do not** place hot parts in water, leave them to cool first.
- **Do not** allow vinegar, coffee, milk, saltwater, lemon, tomato juice or any liquid with high sugar content to remain in contact with the enamel parts of the appliance. Spillages should be wiped up immediately.
- **Do not** allow electrical fittings or cables to come into contact with areas on the appliance that get hot.
- **Do not** use the appliance to heat the room it is located in or to dry clothing. No clothing should be placed over or near to the hob burners or oven door.
- **Do not** install the appliance next to curtains or soft furnishings.
- **Do not** attempt to lift or move cooking appliances by using the oven door or handle, as this may cause damage to the appliance or result in injury to the person lifting the appliance.

## Cleaning

- Cleaning of the oven should be carried out on a regular basis.
- Great care should be taken whilst using this appliance and when following the cleaning procedure.
- ***IMPORTANT: The appliance must be disconnected from the mains before following the cleaning procedure.***
- ***IMPORTANT: Care must be taken when cleaning between the door glasses, and inside the inner frame as some of the edges maybe sharp due to the manufacturing process.***

## Installation



***This appliance must be correctly installed by a suitably qualified person, strictly in accordance with the manufacturer's instructions. Please see the specific section of this booklet that refers to installation.***

- ***Baumatic Ltd. declines any responsibility for injury or damage, to person or property, as a result of improper use or installation of this appliance.***
- Heat, steam and moisture will be created during use of the appliance, take care to avoid injury and ensure that the room is adequately ventilated. If the appliance is going to be used for prolonged periods of time, then additional ventilation may be required.
- Please consult with your qualified installer if you are in any doubt about the amount of ventilation that you will require.

## Declaration of conformity

This appliance complies with the following European Directives:

2006/95/EC regarding "low voltage"  
2004/108/EC regarding "electromagnetic disturbances"  
-89/109/EEC regarding "materials in contact with food".

- The above directives comply with 93/68/EEC regarding CE marking.
- The manufacturer declares that the oven is built using certified materials and requires the appliance to be installed in accordance with the standards currently in force. This appliance must be used by a trained person for domestic purposes only.



## Specifications

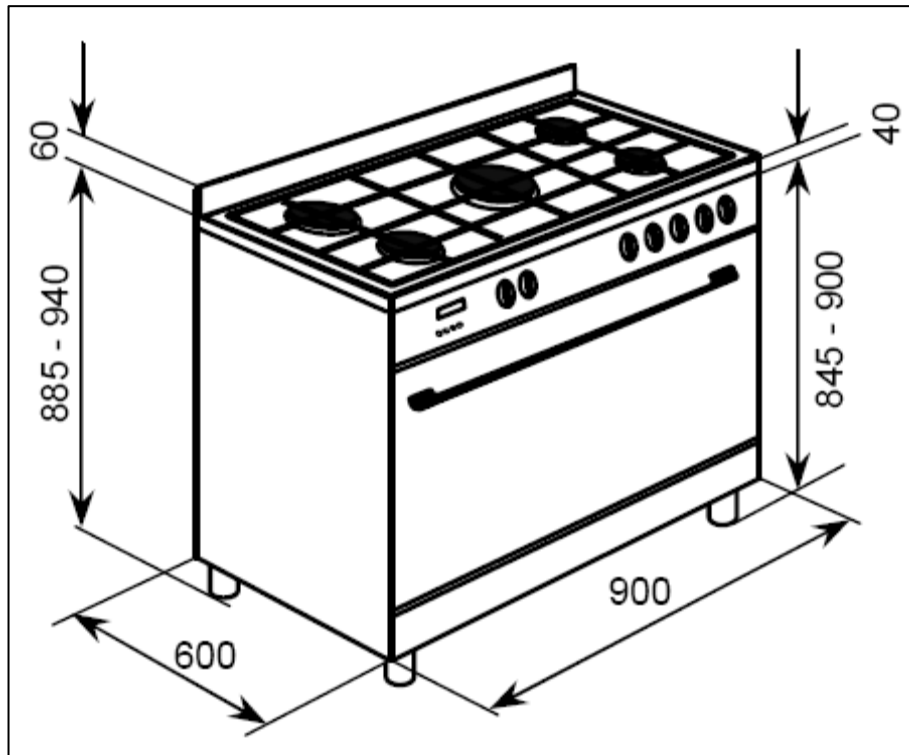

**Height** = 885 - 940 mm

**Width** = 900 mm

**Depth** = 600 mm

### Product specifications:

- **5 zone gas hob:**
- 1 x 3.80 kW triple crown wok burner
- 1 x 3.00 kW rapid burner
- 2 x 1.80 kW semi-rapid burners
- 1 x 1.00 kW auxiliary burner
  
- Flame failure safety device on each burner
- Automatic ignition
- Heavy duty cast iron pan stands
  
- Energy efficiency class: A
- Minute Minder
- Thermostatically controlled grill
- Double-glazed removable door
- Removable full inner glass
- WipeClean enamelled cavity
- Adjustable feet

**Multifunction oven**

- o 8 functions
- o Net oven capacity: 85 litres
- o Gross oven capacity: 112 litres

**Standard accessories:**

- o Trivet
- o WipeClean enamelled baking tray with handle
- o 2 x Safety shelves
- o Removable side racks
- o LPG conversion jets
- o Wok stand

**Optional extras:**

- o BPS2 Pizza Stone

**Electrical details**

<b>Rated Voltage:</b>	230 Vac 50 Hz
<b>Supply Connection:</b>	20 A (double pole switched fused outlet with 3mm contact gap)
<b>Max Rated Inputs:</b>	3.20 kW
<b>Mains Supply Lead:</b>	3 core x 1.5 mm <sup>2</sup> (not supplied)
<b>Oven Light Bulb:</b>	E14 15 W/300°C screw type pygmy

**Gas details**

<b>Gas Connection Type:</b>	1/2" BSP
<b>Gas Type (Natural Gas):</b>	20 mbar

For future reference please record the following information which can be found on the rating plate and the date of purchase which can be found on your sales invoice. The rating plate for your oven can be located by opening the door of the storage compartment.

**Model Number** .....

**Serial Number** .....

**Date of Purchase** .....

## Control Panel

### Cooking zone selection dial

- Turn the relevant dial anticlockwise to select a power level for a chosen burner.

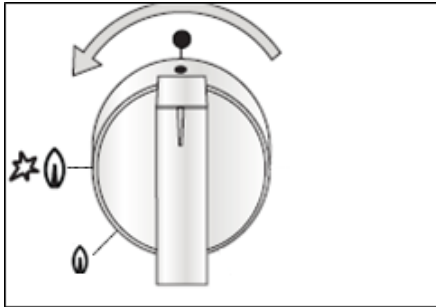

0 = Burner OFF position



– Low temperature



– High temperature

### Main oven thermostat dial

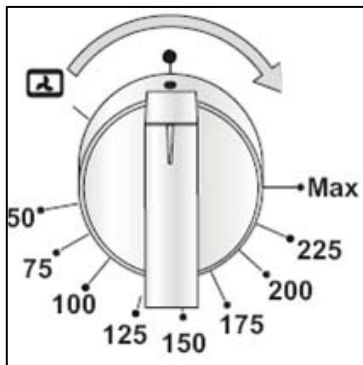

- Turn the dial clockwise to select a main oven temperature (50 °C – 225 °C MAX).

### Main oven function selection dial

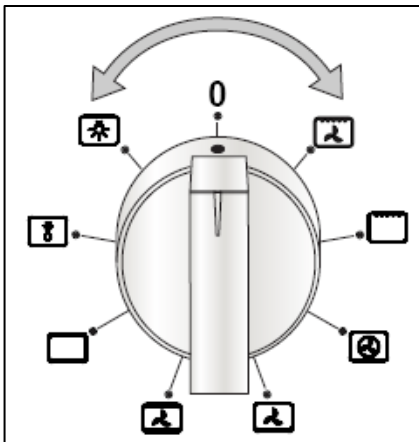

- Rotate the dial to select a function for the main oven.

### Analogue Thermometer

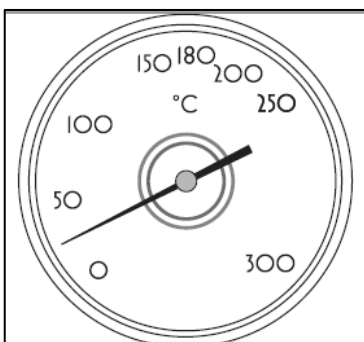

- The control panel has an analog thermostat which displays the approximate internal temperature of the main oven.

## The timer (minute-minder)

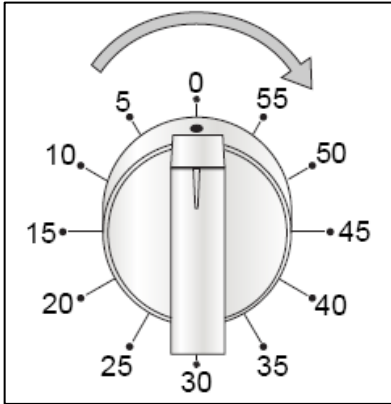

- To set a cooking time, first wind the timer up by turning it completely once from left to right and then back to the number of minutes you require the timer to be set for.
- The timer will sound when the set time has been reached.

## Using the hob top

### Hob surface layout

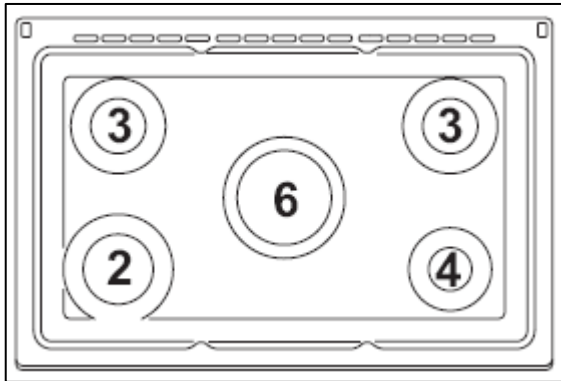

- 2) 3.00 kW rapid burner
- 3) 1.80 kW semi-rapid burners
- 4) 1.00 kW auxiliary burner
- 6) 3.80 kW triple crown (wok) burner

### Before first use



**IMPORTANT:** You should clean the hob surface (see "Cleaning and maintenance" section).

- You should switch on one cooking zone at a time, for 5 minutes at the maximum setting. This will help to eliminate any new smell that exists and evaporate any humidity that has formed on the heating elements during transit.
- Do not burn off more than one zone at once.
- **You must** place a saucepan filled half full with cold water on each zone as you burn it off.

## Lighting a burner

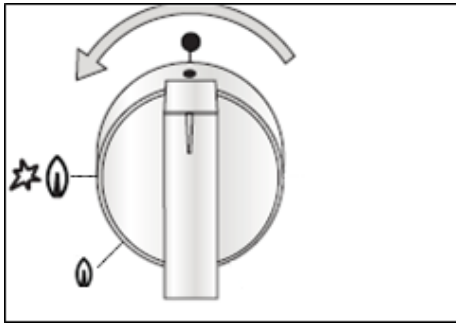

- Press the relevant burner dial and rotate anticlockwise to the large flame icon. Release the dial and the burner will automatically ignite.
- Matches can also be used to light the burner during a power cut. Simply follow the previous step but place a lit match to the burner as you press the dial. Once lit, keep the dial pressed for about ten seconds.

***WARNING: Extra care should be taken when lighting a burner with matches. There is a risk of burning as the cooking zone ignites so take necessary precautions.***

## Optimum use of the burners

- In order to achieve maximum results with the minimum consumption of gas, it is important to adjust the flame according to your needs and to use the appropriate size pans (see table below).
- When the contents of a pan begin to boil it is recommended that you adjust the dial to the small flame position.
- Always place a lid on the pan in use.

<b><i>Burner</i></b>	<b><i>Diameter of pan (cm)</i></b>
Triple crown	22 – 24
Rapid	20 – 22
Semi-rapid	16 – 18
Auxiliary	12 - 14

- *Always remember to turn the control knob to OFF when cooking is completed.*

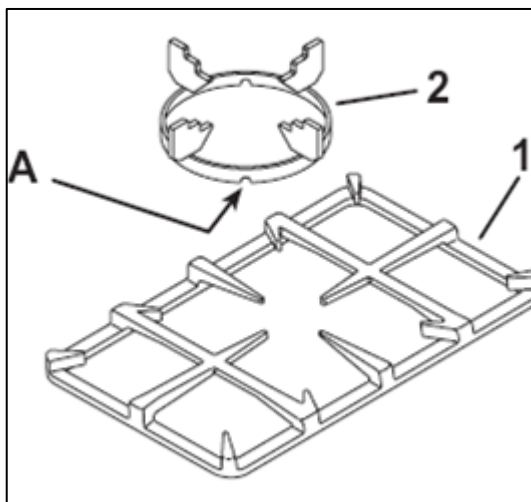

- The appliance is equipped with pan supports (1), on which the wok support (2) must be placed. To ensure stability, position the notch (A) of the wok support on the pan support fingers as indicated in the diagram above.

## Hob guidelines

- The diameter of the bottom of the pan should correspond to that of the burner.

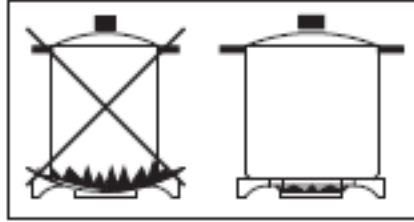

- The burner flame must never extend beyond the diameter of the pan.
- Use flat bottomed pans only
- When possible, keep a lid on the pan whilst cooking.
- Cook vegetables with as little water as possible, to reduce cooking times.

***IMPORTANT:*** Always place pans centrally over the hob burners and position them so that the handles cannot get accidentally caught or knocked off. You should also make sure that the handle is not over one of the other hob burner flames.

## Using the oven

### Before first use

- To remove any residue from the oven that may have been left from the manufacturing process, you should select the conventional oven function and turn the thermostat dial to its maximum temperature setting.
- It is perfectly normal for a smell to be produced during this process.
- You should make sure that any windows in the room are left open during this process.
- It is advisable for you not to remain in the room whilst the burning off process is taking place.
- You should leave each oven on maximum setting for 30 – 40 minutes.

- After the cavity has cooled, it should then be cleaned with warm soapy water, using either a sponge or soft cloth. No abrasive cleaners should be used.
- Outer parts of the oven should be cleaned with warm soapy water, using either a sponge or soft cloth. No abrasive cleaners should be used.
- We would recommend that an appropriate stainless steel cleaner and polish is regularly used on the stainless steel surfaces of this appliance.

### Using the main oven

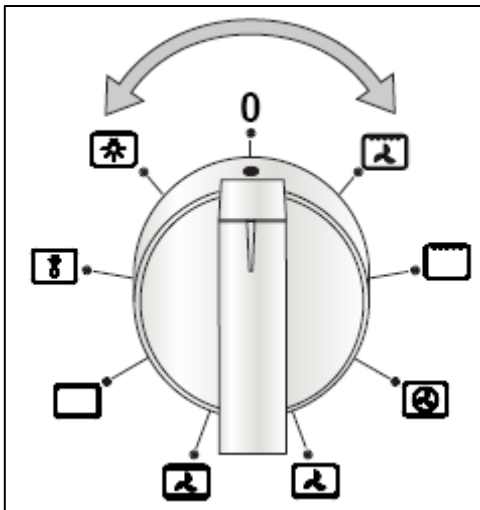

You can rotate this dial in either direction to select an oven function for the oven.

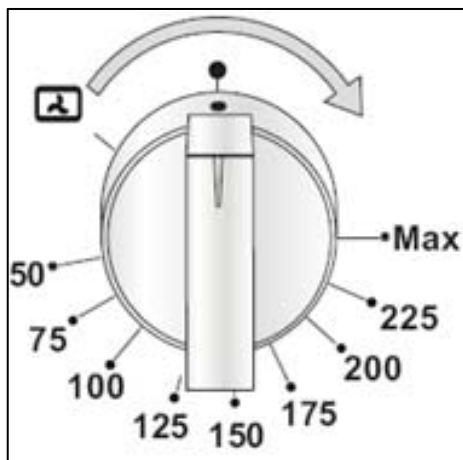

The oven temperature control knob should be turned clockwise to select the oven temperature.

There are eight cooking functions available on your appliance:



**LIGHT CONTROL:** Turn the control knob to this icon to turn the oven light on and off.



**DEFROST MODE:** The fan runs without heat to reduce the defrosting time of frozen foods. The time required to defrost the food will depend on the room temperature, the quantity and type of food. Always check food packaging for the defrosting instructions.



**FAN OVEN:** This method of cooking uses the top and bottom heating elements with the fan. This results in the heat being evenly distributed in the cavity to cook food simultaneously on different shelves and also prevents the transmission of smells and tastes from one dish to another.



**CONVENTIONAL OVEN:** This method of cooking provides traditional cooking, with heat from the top and lower elements. This function is suitable for roasting and baking on one shelf only.



**GRILL WITH FAN:** This cooking method uses the top element in conjunction with the fan, to help give a fast circulation of heat. Suitable where quick browning is required and "sealing" the juices in, such as with steaks, hamburgers, some vegetables etc.



**CENTRE GRILL:** This cooking method is normal grilling, utilising the inner part only of the top element, which directs heat downwards onto the food. Suitable for grilling small portions of bacon, toast, meat etc.



**BOTTOM HEATING ELEMENT AND FAN:** This function uses the bottom heating element and the fan to distribute the heat. It is suitable for defrosting and warming up ready-made meals.



**CIRCULAR HEATING ELEMENT AND FAN:** This function turns on the back heating unit and the fan to distribute the heat. This combination allows for a fast and even cooking of several different foods placed on the various shelf levels.



## Using the grill

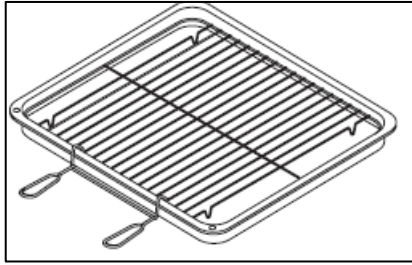

The control knobs should be used to select the grill function and temperature that you require. We recommend that you preheat the grill for five minutes before putting food into the grill.

**IMPORTANT:** *The oven door must be closed when using the grill function.*

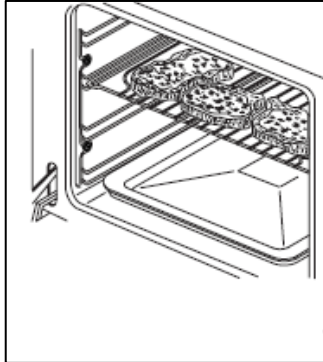

**REMEMBER:** *When using any of the grill functions, it is important to place a drip pan at the base of the oven cavity to collect any juices which may drip down (see image on next page).*

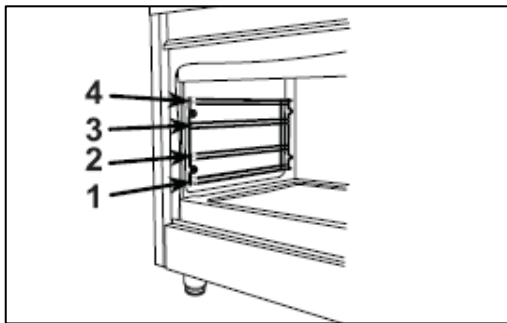

The oven walls of the two cavities are fitted with various guide bars on which you can place an oven shelf or a drip tray (see image below).

## Cooking guidelines

- Please refer to the information given on food packaging for guidance on cooking temperatures and times. Once familiar with the performance of your appliance, temperatures and times can be varied to suit personal preference.
- Make sure that frozen foods are thoroughly thawed before cooking, unless the instructions on the food packaging advise that you can "cook from frozen".
- You should pre-heat the oven and not place food inside of it is properly heated.
- Before cooking, check that any unused accessories are removed from the oven.
- Place cooking trays in the centre of the oven and leave gaps between the trays to allow air to circulate.
- Try to open the door as little as possible to view the dishes.

## Warnings

- Keep the oven door closed when using either the grill or oven functions.
- During cooking, never place pans or cookware directly onto the bottom of the oven. They should always be placed on the shelves provided.
- The grill heating element becomes extremely hot during operation, avoid touching it inadvertently when handling the food which you are grilling.
- **Important:** Be careful when opening the door, to avoid contact with hot parts and steam.
- **IMPORTANT:** In case of fire, close the main valve of the gas supply and switch off the electricity supply to the appliance. **NEVER** pour water onto burning oil.

For a general cooking guide please see the tables below.

## Cooking guide for the main oven

### Multifunction oven:

Foods	Weight (kg)	Shelf position from bottom			Cooking without fan		Cooking with fan	
		With 5 runners	With 4 runners	With three runners	Temperature (°C)	Cooking time in mins	Temperature (°C)	Cooking time in mins
<b>Meat</b>								
Roast veal	1	1-2	1-2	2	200-225	100-120	190	100-120
Roast beef	1	1-2	1-2	1	200-225	40-50	190	40-50
Roast pork	1	1-2	1-2	2	200-225	100-120	190	100-120
Roast lamb	1	1-2	1-2	1	200-225	100-120	190	100-120
<b>Game</b>								
Roast hare	1	1-2	1-2	2	200-MAX	50-60	200-MAX	50
Roast pheasant	1	1-2	1-2	2	200-MAX	60-70	200-MAX	60
Roast partridge	1	1-2	1-2	2	200-MAX	50-60	200-MAX	50
<b>Poultry</b>								
Roast chicken	1	1-2	1-2	2	200-225	80-90	190	70-80
Roast turkey	1	1-2	1-2	2	200-225	100-120	190	90-110
Roast duck	1	1-2	1-2	2	200-225	90-110	190	80-100
<b>Fish</b>								
Roast fish	1	2-3	2	1	200	30-35	170-190	25-30
Casserole fish	1	2-3	2	1	175	20-25	160-170	15-20

<b>Baked pasta</b>									
Lasagne	2.5	3	2	1	210-225	60-75	225-MAX	30-40	
Cannelloni	2.5	3	2	1	210-225	60-75	225-MAX	30-40	
<b>Pizza</b>	1	3	2	1	225-MAX	25-30	225-MAX	20-25	
<b>Bread</b>	1	3	2	1	225-MAX	20-25	220	20	
<b>Pastries</b>									
Biscuits in general		2	2	1	190	15	170-190	15	
Shortcrust pastry		2	2	1	200	20	190-200	20	
Victoria sponge	0.8	2	2	1	200	40-45	190-200	40-45	
<b>Cakes</b>									
Angel cake	0.8	2	2	2	190	52	170-190	45	
Fruit cake	0.8	2	2	2	200	65	190-200	65	
Chocolate cake	0.8	2	2	2	200	45	190-200	45	

*The information in this table is approximate and may vary according to individual needs.*

**Grilling:**

Foods	Weight (kg)	Shelf position from bottom			Cooking without fan			Cooking with fan		
		With 5 runners	With 4 runners	With 3 runners	Temperature (°C)	Cooking time in mins		Temperature (°C)	Cooking time in mins	
						1 <sup>st</sup> side	2 <sup>nd</sup> side		1 <sup>st</sup> side	2 <sup>nd</sup> side
<b>Meat</b>										
Chop	0.50	3	3	2	225-MAX	12-15	12-15	200	15	10
Beef Steaks	0.15	3-4	3	1-2	200-225	5	5	Depends on thickness and personal taste	Depends on thickness and personal taste	
Half chicken (0.5kg each half)	1	3-4	2-3	1-2	225	20	20			
<b>Fish</b>										
Trout	0.42	4	3	2-3	225-MAX			200	10	10
Sole	0.20	4	3	2-3	225-MAX			200	7	7
<b>Bread</b>										
Toast		4-5	3-4	3	225-MAX	2-3	2-3	200	2-3	2-3

*The information in this table is approximate and may vary according to individual needs.*

## **Cooking tips for cakes and bread**

- Heat the oven for at least 15 minutes before you start cooking bread or cakes.
- Do not open the door during baking because the cold air will stop the yeast from rising.
- When the cake is cooked turn the oven off and leave it in for about 10 minutes.
- Do not use the enamelled baking tray or drip pan to cook cakes in.
- To test if a cake is cooked, about 5 minutes before the end of cooking time, put a cake tester or skewer in the highest part of the cake. If it comes out clean, the cake is cooked.
- If the cake sinks, next time use less liquid or lower the temperature by 10°C.
- If the cake is too dry, make some tiny holes with a toothpick and pour some drops of fruit juice or spirits on it. The next time, increase the temperature by 10°C and set a shorter cooking time.
- If the cake is too dark on top next time put the cake on a lower shelf and cook it at a lower temperature for longer.
- If the top of the cake is burnt, cut off the burnt layer and cover with sugar or decorate with cream, jam and confectioner's cream.
- If the cake is too dark underneath next time place it on a higher shelf and cook it at a lower temperature.
- If the cake or bread is cooked nicely outside but is still uncooked inside, next time use less liquid and cook at a lower temperature for longer.
- If the cake will not come out of the tin, slide a knife around the edges, place a damp cloth over the cake and turn the tin upside down. Next time, grease the tin well and sprinkle with flour or bread crumbs.
- If the biscuits will not come away from the baking tray, put the tray back in the oven for a while and lift the biscuits up before they cool. The next time use a sheet of baking parchment to prevent this happening again.

## Cooking tips for meat

- If, when cooking meat, the time needed is more than 40 minutes, turn the oven off 10 minutes before the end of cooking time to exploit the residual heat and save energy.
- Your roast will be juicier if cooked in a closed pan. It will be crispier if cooked without a lid.
- Normally white meat, poultry and fish need medium temperatures (less than 200°C).
- To cook "rare" red meats, high temperatures (over 200°C) and short cooking times are needed.
- For a tasty roast, lard and spice the meat.
- If your roast is tough, next time leave the meat to ripen longer.
- If your roast is too dark on top or underneath, next time put it on a higher or lower shelf, lower the temperature and cook for longer.
- If your roast is undercooked, cut it in slices and arrange the slices on a baking tray with gravy and finish cooking it.

## Cleaning and maintenance



***Cleaning operations must only be carried out when the oven is cool.***

***The appliance should be disconnected from your mains supply before commencing any cleaning process.***

- The oven should be thoroughly cleaned before it is operated for the first time and after each use. This will avoid residual food stuffs becoming baked on the oven cavity. After residues have been baked on several times, they are far more difficult to remove.
- ***Never*** clean the oven surfaces by steam cleaning.
- The oven cavity should only be cleaned with warm soapy water, using either a sponge or soft cloth. No abrasive cleaners should be used.

- Any stains that may appear on the bottom of the oven will have originated from food splashes or spilt food, these splashes occur during the cooking process. These could possibly be a result of the food being cooked at an excessively high temperature or being placed in cookware that is too small.
- You should select a cooking temperature that is appropriate for the food that you are cooking. You should also ensure that the food is placed in an adequately sized dish and that you use the enamelled baking tray where appropriate.
- Outer parts of the oven should only be cleaned with warm soapy water, using either a sponge or soft cloth. No abrasive cleaners should be used.
- We would recommend that an appropriate stainless steel cleaner and polish is regularly used on the stainless steel surfaces of this appliance.
- If you use any form of oven cleaner on your appliance, then you must check with the manufacturer of the cleaner that it is suitable for use on your appliance.
- ***Any damage that is caused to the appliance by a cleaning product will not be fixed by Baumatic free of charge, even if the appliance is within the guarantee period.***

### **Cleaning the gas hob top**

- Remove the dirty pan supports from the hob and place in warm soapy water for some time. Then wash and dry before replacing.

### **After each use**

- Wipe the appliance over with a damp cloth and a little washing up liquid.
- Dry the appliance by rubbing the surface with a clean cloth.

## Cleaning the burners

- Gas burners should be cleaned regularly and after each spillage to remove cooking residues and dirt.

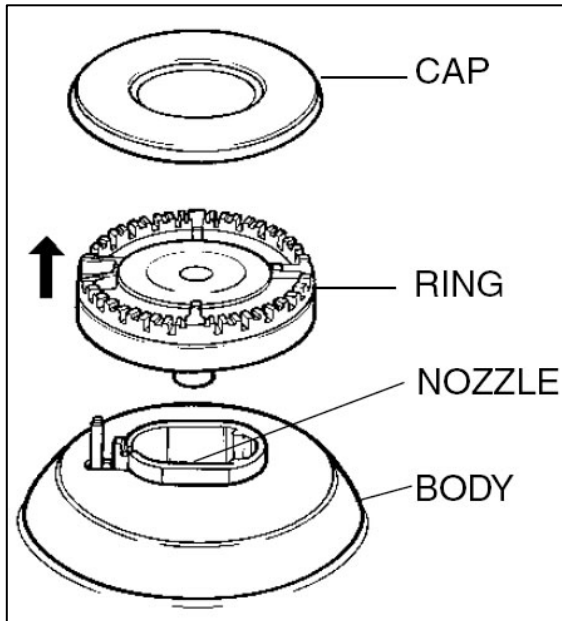

- To clean the burners, remove the caps and rings and place them separately in warm soapy water. After cleaning them, check that the burner ports are clear.
- The body near the nozzle should always be clean. Dirt accumulating around the nozzle may clog it, as a result of which the burner will not light or will light only with a small flame. To clean the nozzle use a brush soaked in solvent.

- Dry all the elements of the burner carefully as wet elements may not light properly. Assemble the clean and dry burners carrying out the disassembly steps in reverse order.

## Cleaning the oven

- The oven compartment is coated with vitreous enamel. To clean particularly difficult burnt spots a special oven cleaning agent may be used. However, as these agents are caustic, be careful when using them and follow the manufacturer's guidelines.

***Warning: Do not steam pressure clean the oven.  
Always wait until the oven cools down before cleaning.***

## Replacing the oven bulb



**IMPORTANT:** *The oven must be disconnected from your mains supply before you attempt to either remove or replace the oven bulb.*

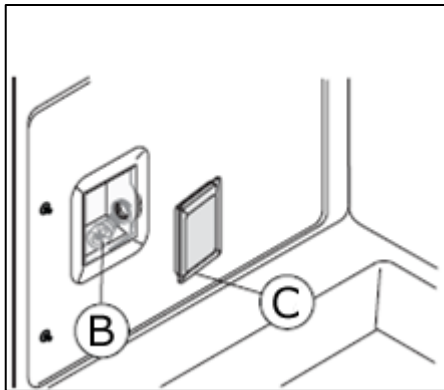

- Draw out the side guide rails in order to provide access to the bulb.
- Remove the glass protection cap **(C)** from the bulb socket by lifting it with a screwdriver placed between the cap and the oven wall.
- Replace the bulb **(B)** with a 15 W/300°C, screw type pygmy.

- **Do not** use any other type of bulb.
- Screw the lamp cover back into its original position.

## Removing the oven door for cleaning

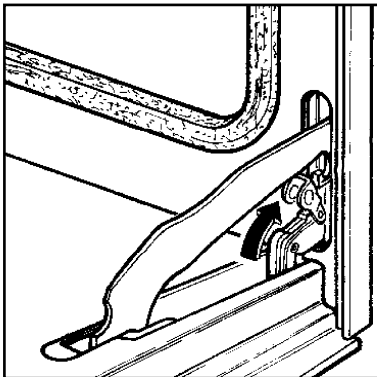

- The oven door can be removed to give easier access to the oven when cleaning.
- Open the oven door and move the release U-shape element forward until it is over the tooth in the upper sector of the hinge (see image below).
- Partially close the door, forcing it upwards at the same time to free the stop tooth and hinge sector.
- Once the hinge is free, pull the door forwards tilting it slightly upwards to free the sector.
- To reassemble, proceed in the reverse order, playing attention to the correct position of the sectors.



## Removing the inner door glass for cleaning

*Ensure the top cavity is cold before cleaning.*

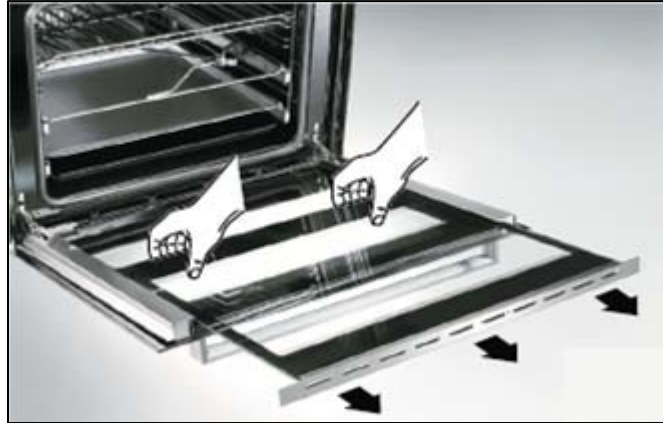

- Simply open the oven door and remove the support securing the glass. The glass will then slide out easily.
- To replace the glass, follow the first step in reverse.

***WARNING: This procedure can be carried out with the door fitted on the appliance but pay attention that when the glass is pulled upwards, the force of the hinges can close the door roughly.***

- ***IMPORTANT:*** You should make sure that the door is supported at all times and that you place the door on some padded material whilst cleaning it.
- The oven door and door glass should only be cleaned using a damp cloth and a small amount of detergent. The cloth ***MUST NOT*** have come into contact with any form of cleaning product or chemical previously.

## Removing the side racks for cleaning

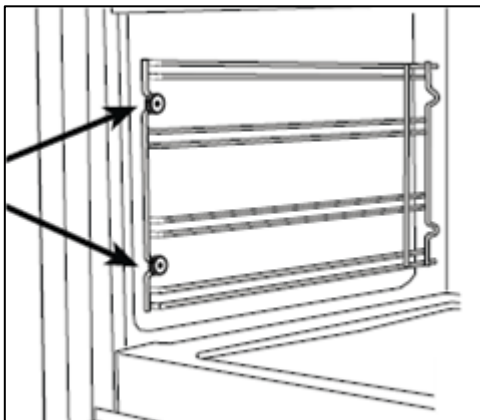

- For an effective cleaning of the oven side guide rails, these can be extracted by unscrewing the knurled nuts.
- To fit the rails back in their place, first insert rear pins in the holes and then secure them with the knurled nuts.

## Installation



*The installation must be carried out by a suitably qualified person, in accordance with the current version of the following.*

- *UK Regulations and Safety Standards or their European Norm Replacements.*
- *Building Regulations* (issued by the Department of the Environment).
- *Building Standards* (issued by the Scottish Development Department).
- *IEE Wiring Regulations.*
- *Electricity At Work Regulations.*
- *Gas Safety (Installation and Use) (Amendment) Regulations.*

### Positioning



*The adjacent furniture and all materials used in the installation must be able to withstand a minimum temperature of 85°C above the ambient temperature of the room it is located in, whilst in use.*

- Your appliance is heavy, so you should be careful when moving or positioning it.
- **Do not** try to move the cooker by pulling on either the door, handle or control panel.

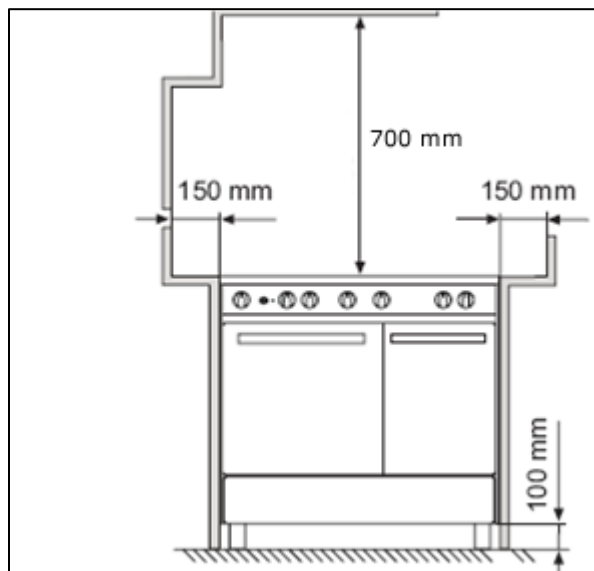

- It can also be used as freestanding, with a cabinet to one side, in a corner setting or with its back to a wall.

- **IMPORTANT:** It should not be installed at the end of a run of cabinets, if there is a cabinet at immediate right angles to the cooker door.
- The wall behind the cooker and 450 mm above and across the width of the cooker should be an incombustible material and preferably an easy clean surface, such as ceramic tiles.
- Any overhanging surface or cooker hood should be **at least 700 mm** above the highest point on the hob top (including the burners).
- Baumatic do not recommend that the cooker is positioned below wall cupboards, as the heat and steam from the appliance and what is being cooked, may damage the cupboard and its contents.
- The cooker may be located in a kitchen, or a bedroom, but not in a room containing a bath or shower. **The cooker must not be installed in a bedroom of less than 20m<sup>3</sup> in size.**

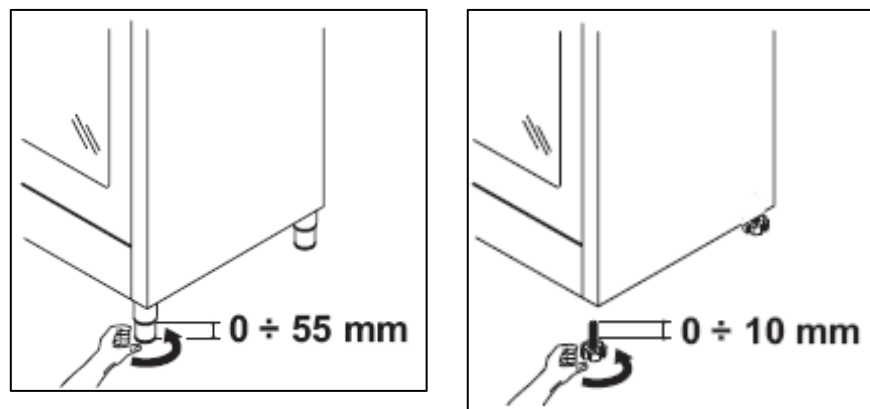

- The cooker is fitted with four legs that can be adjusted to match the height of your kitchen cabinets.
- If the cooker is not level or is unstable due to an uneven floor surface, use the adjustable feet to alter each corner until the cooker is level.
- To assemble them it is necessary to raise the cooker and to screw the four legs into position, on each corner of the base of the appliance.
- **IMPORTANT:** They must be screwed clockwise into position and not just slotted into the holes on each corner. You must screw them through the brackets that are also provided.

## Ventilation requirements

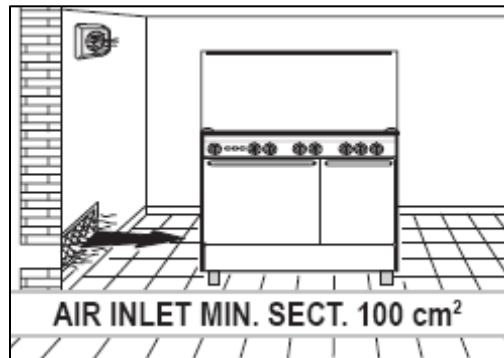
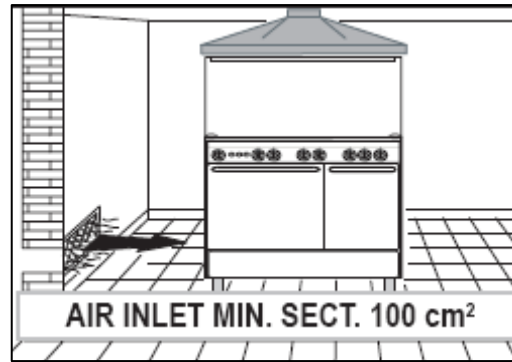
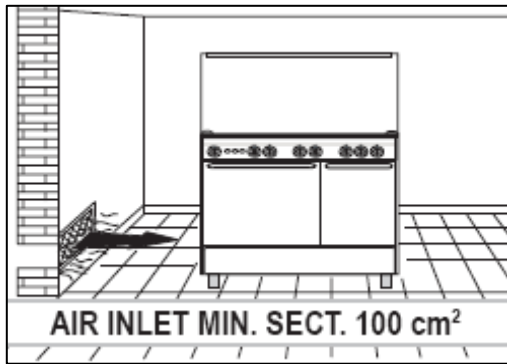

- The room containing the cooker should have an air supply in accordance with the current edition of BS 5440: Part 2:
- The room must have opening windows or equivalent; some rooms may also require a permanent vent.
- If the room has a volume between 5 and 10m<sup>3</sup>, it will require an air vent of 50cm<sup>2</sup> (effective area). Unless it has a door which opens directly to the outside.
- If the room has a volume of less than 5m<sup>3</sup>, it will require an air vent of 100cm<sup>2</sup> (effective area).
- If there are any other fuel burning appliances in the same room the current edition of BS 5440: Part 2: should be consulted to determine air vent requirements.
- Ensure that the room containing the cooker is well ventilated, keep natural ventilation holes or install a mechanical ventilation device (mechanical cooker hood).
- Prolonged intensive use of the appliance may call for additional ventilation, either by the opening of a window, or by increasing the level of the mechanical ventilation device (where present).

- This cooker is not fitted with a device for discharging the products of combustion. Ensure that the ventilation rules and regulations are followed.
- Excess steam from the oven, vents out at the top back edge of the cooker, so make sure that the walls behind and near the cooker are resistant to heat, steam and condensation.
- Your cooker must stand on a flat surface so that when it is in position the hob is level. When in position check that the cooker is level by using a spirit level and adjust the 2 feet at the rear and the 2 feet at the front if necessary.
- Remember that the quantity of air necessary for combustion must never be less than 2m<sup>3</sup>/h for each kW of power (see total power in kW on the appliance rating plate).

### Securing the back-guard

- In order to attach the back-guard (**A**) to the appliance, you need to loosen the screws (**B**) positioned on the back of the hob (see image below).

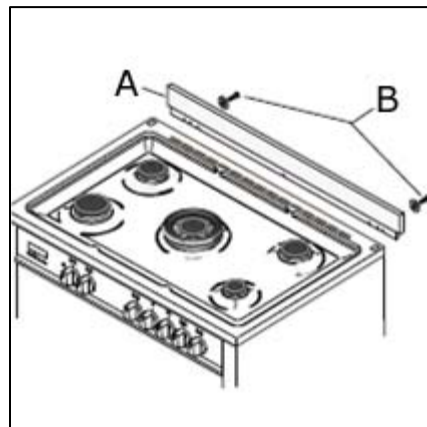

- Fix the back-guard into place by screwing the screws back into the hob with the back-guard placed in between.

### Fitting the safety chain and hook

- To prevent the cooker from tipping forward, two lengths of chain **MUST BE** fixed to the back of the oven which should be secured to the hook provided at all times.
- The hook should be secured to the wall at the back of the cooker. The chains should always be attached to the upper hook when the cooker is in position against the wall.

- Attach the chain to the lower hook if the cooker is installed with a hose assembly so that there is no strain on the hose when the cooker is pulled forward for cleaning or maintenance.

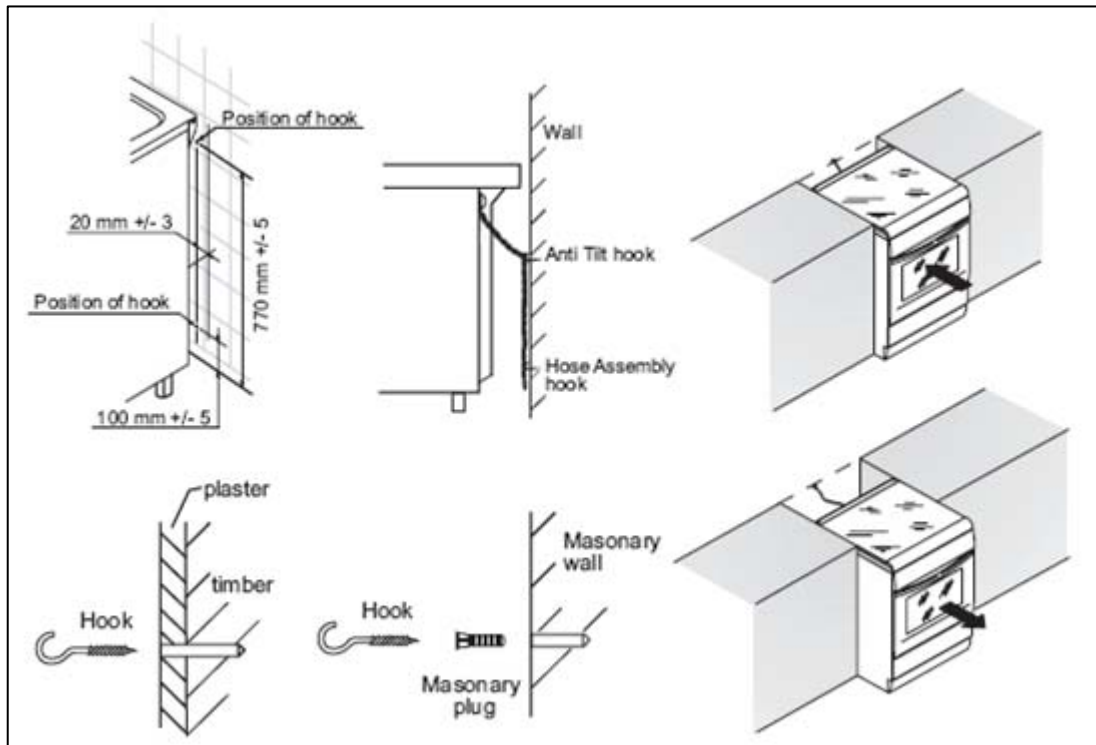

- Fix the upper hook into the wall immediately behind and to the left hand side about 770 mm from the floor.
- Secure the chain to the hook before using or cleaning the oven.
- To prevent strain on the flexible hose assembly, a lower chain and hook can be fixed approximately 100 mm up from the floor

## Electrical connection



*This appliance must be installed by a qualified person in accordance with the latest edition of the I.E.E. Regulations and in compliance with Baumatic's instructions.*

Before connecting the appliance, make sure that the supply voltage marked on the rating plate corresponds with your mains supply voltage.

### **WARNING: THIS APPLIANCE MUST BE EARTHED.**

- This appliance must be wired into a 20 A double pole switched fused spur outlet, having 3 mm contact separation and placed in an easily accessible position adjacent to the appliance. It should not be located above the appliance and no more than 1.25m away from it.
- The spur outlet must still be accessible even when your oven is located in its operating position.
- Cable type: H05 RRF 3 core x 1.5 mm<sup>2</sup>

### Connecting the mains supply cable

#### **IMPORTANT**

*The wires in the mains lead are coloured in accordance with the following code:*

**GREEN AND YELLOW**  
**BLUE**  
**BROWN**

**EARTH**  
**NEUTRAL**  
**LIVE**

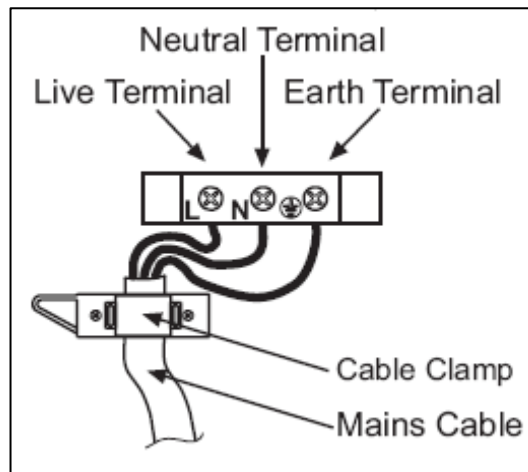

- Release the cover plate by removing the cover screw.

- Loosen the cable clamp.
- Feed the mains connection cable through the grommet in the back panel and cable clamp. Connect the mains supply cable to the terminal block on the cooker using the colour code on the previous page.
- Secure the cable clamp. Check the cable terminals for tightness and ensure that the terminal links are in place, then replace the cover plate and cover screw.

## Gas connection



***This appliance must be installed by a competent person in accordance with the current versions of the following UK (United Kingdom) or ROI (Republic of Ireland) Regulations and Safety Standards or their European Norm Replacements.***

## Important information

- This cooker is supplied to run on **natural gas only** and cannot be used on any other type of gas without modification.
- Conversion for use on LPG and other gases must only be undertaken by a qualified person. For information on the use of other gases, please contact the Baumatic Technical Department.
- The cooker must be installed by a qualified person, in accordance with the current edition of the Gas Safety (Installation and Use) (Amendment) Regulations and the relevant building/I.E.E. Regulations.
- Failure to install the appliance correctly could invalidate Baumatic's guarantee and lead to prosecution under the regulations quoted above.
- In the UK, **GASSAFE** registered installers are authorised to undertake the installation and service work, in compliance with the above regulations.



## Gas Safety (Installation and Use) Regulations

- It is the law that all gas appliances are installed by competent persons in accordance with the current edition of the ***Gas Safety Installation and Use Regulations***.
- It is in your interest and that of safety to ensure compliance with the law.
- In the UK, GASSAFE registered installers work to safe standards of practice. The cooker must also be installed in accordance with the current edition of BS 6172. Failure to install the cooker correctly could invalidate the warranty, liability claims and lead to prosecution.
- ***IMPORTANT: It is a requirement for a stability chain to be fitted to the appliance. Please see page 35 for more detailed information on this.***

### Gas connection



***ALL INSTALLATION AND SERVICE WORK MUST BE CARRIED OUT BY A GASSAFE REGISTERED ENGINEER.***

- Prior to installation, ensure that the gas supply conditions (nature of the gas and gas pressure) and the adjustment conditions are compatible. The adjustment conditions for this appliance are stated on the rating plate which can be found on the back cover.
- This appliance is not designed to be connected to a combustion product evacuation device. Particular attention should be given to the relevant requirements regarding ventilation.
- ***IMPORTANT: THE FIBRE WASHERS MUST BE IN PLACE WHEN CONNECTING THE ADAPTOR ELBOW.***
- Connect the short transition pipe to the elbow, inserting the washer. Connect the brass adapter with the test point to the nut of the transition pipe, inserting the washer. Then fix the retention device with the screw.
- Connection to the cooker should be made with an approved appliance flexible connection to BS 669.
- If the cooker has been converted for use with LPG, then it should be connected to the gas supply using an appropriate bayonet

type hose. The hose **MUST** be suitable for use with LPG gas, these are identifiable by a red band or stripe.

- A hose length of 0.9m to 1.25m is recommended. The length of hose chosen should be such that when the cooker is in situ, the hose does not touch the floor.
- Care should be taken to ensure that the temperature rise of areas at the rear of the cooker that are likely to come in contact with the flexible hose do not exceed 70°C.
- Gas pressure may be checked on a semi-rapid hob burner. Remove the appropriate injector and attach a test nipple. Light the other burners and observe that the gas pressure complies with the gas standards in force.

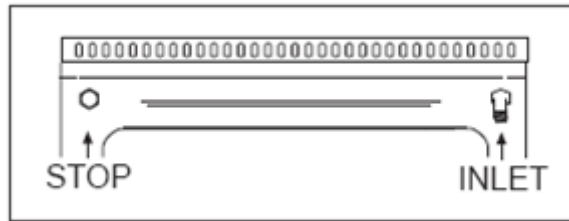

- This cooker can be connected to the supply both on the right and left hand side at the rear of the cooker. To reverse the position, remove the blanking plug and refit it to the opposite side to where the hose is being connected.

### Gas adjustment (Conversion to LPG for the hob top)



***All work must be carried out by a GASSAFE registered engineer.***

***IMPORTANT: Always isolate the cooker from the electricity supply before changing the injectors and/or adjusting the minimum flow of the burners.***

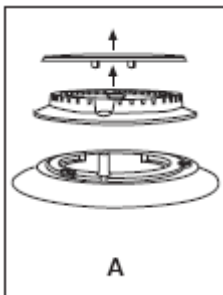

- Remove the pan-stands, burners and flame spreaders **(A)**.

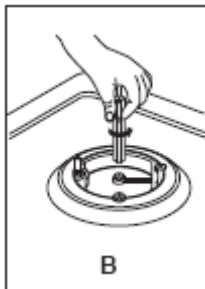

- Unscrew the injector **(B)** and replace it with the stipulated injector for the new gas supply (see table on the next page).

Burner	Operating pressure gas		Rate		Diameter injector	Heat Input (W)		By-Pass
	mbar		g/h	L/h	1/100mm	Min	Max	1/100mm
Rapid	G30 - Butane	28 - 30	218	N/A	88	800	3000	44
	G31 - Propane	37	214	N/A	88	800	3000	
	G20 - Natural	20	N/A	286	117 - Y	800	3000	
Semi - rapid	G30 - Butane	28 - 30	131	N/A	68	600	1800	34
	G31 - Propane	37	129	N/A	68	600	1800	
	G20 - Natural	20	N/A	171	98 - Z	600	1800	
Auxiliary	G30 - Butane	28 - 30	73	N/A	51	400	1000	28
	G31 - Propane	37	71	N/A	51	400	1000	
	G20 - Natural	20	N/A	95	75 - X	400	1000	
Triple Crown	G30 - Butane	28 - 30	276	N/A	98	1400	3800	62
	G31 - Propane	37	272	N/A	98	1400	3800	
	G20 - Natural	20	N/A	362	135 - K	1400	3800	

- Reassemble all the burners carefully; in particular you should make sure that the flame spreader is correctly placed on the burner.

**IMPORTANT: After changing the injectors YOU MUST follow the minimum flow adjustment section below.**

**Minimum flow adjustment for hob gas taps.**



**All work must be carried out by a GASSAFE registered engineer.**

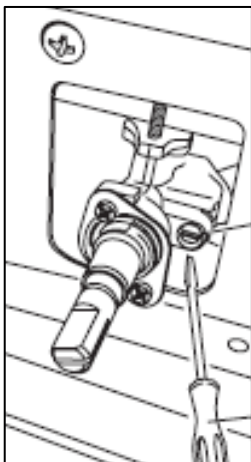

- Light the burner and set the knob at the minimum position.
- Remove the knob from the tap. The adjustment screw is located beside the valve body.
- Place a small bladed screwdriver in the centre of the tap shaft.
- Unscrew the adjusting screw, in order to increase the gas flow or tighten the adjusting screw to decrease the gas flow.

- The correct adjustment is obtained when the flame has a length of about 3 – 4 mm.
- For butane/propane gas, the adjusting screw must be tightly screwed in.
- Refit the control knob.
- Make sure that the flame does not go out by quickly turning from maximum flow to minimum flow. If it does then remove the control knob and make further adjustments to the gas flow, testing it again once the adjustment has been made.
- **IMPORTANT: On completion carry out a gas tightness test.**

### Gas tap replacement



**All work must be carried out by a GASSAFE registered engineer.**

**IMPORTANT: Always isolate the cooker from the electricity supply before changing the gas taps.**

- Remove all pan supports and burner heads.
- Unscrew the burner fixing screws **(A)** (four for the triple crown burner and two for all others) as shown in the diagram below:

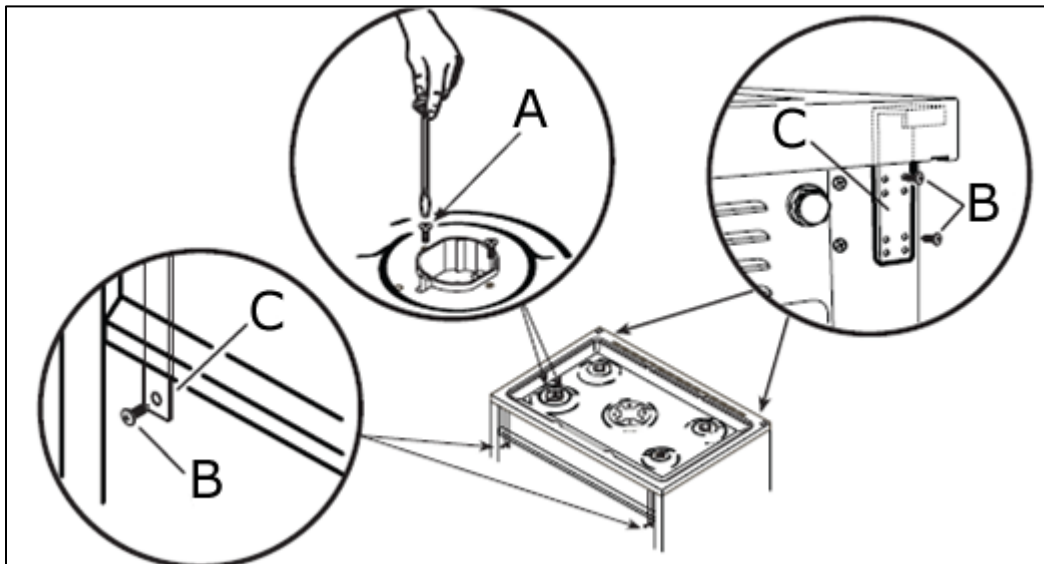

- Pull out the knobs.
- Unscrew the six fixing screws **(B)** which lock the side profiles and remove it.

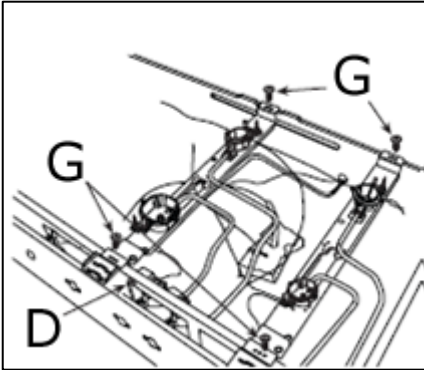
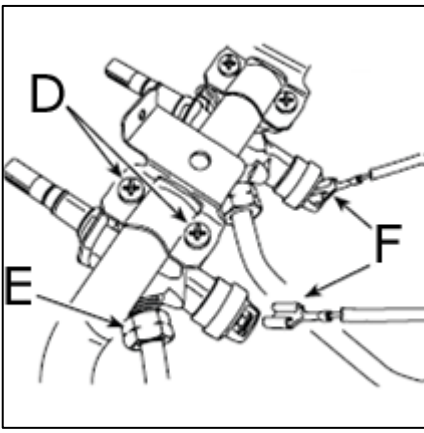

- Remove the hob by unscrewing the rear fixing screws **(B)** which lock the hob at the supports **(C)**.
- Unscrew the nuts **(E)** of the gas aluminium pipes and pull out the thermocouple quick connectors **(F)**.
- Unscrew the screws **(D)** which lock the crosspieces.
- Unscrew the screws **(G)** which unite the bridles of the taps to the front frame.
- Slip the ramp towards the back part and unscrew the screws **(G)** in order to free the taps.
- Change the seal each time a tap or a thermostat is replaced. This will ensure perfect retention between the tap or a thermostat and part.
- Reassemble all the parts following the same procedure but in the reverse order.

### My appliance isn't working correctly

- ***The oven isn't coming on.***
  - \* Check that the oven is in manual operation mode.
  - \* Check that you have selected a cooking function and a cooking temperature.
- ***There appears to be no power to the oven and grill.***
  - \* Check that the appliance has been connected to the electrical mains supply correctly.
  - \* Check that the mains fuses are in working order.
  - \* Check that the operating instructions for setting the time of day and putting the appliance into manual operation mode have been followed.

- ***The grill function works but the main oven does not.***
- \* Check that you have selected the correct cooking function.
- ***The grill and top oven element is not working, or cuts out for long periods of time during use.***
- \* Allow the oven to cool for approximately 2 hours. Once cool, check whether the appliance is again working properly.
- ***My food is not cooking properly***
- \* Ensure that you are selecting the correct temperature and the correct cooking function for the food that you are cooking. It may be appropriate to adjust your cooking temperature to achieve the best cooking results.
- ***My food is not cooking evenly***
- \* Check that the oven has been installed correctly and is level.
- \* Check that the correct temperatures and shelf positions are being used.
- ***The oven light is not working***
- \* Refer the "Replacing the oven bulb" section.
- ***I am getting condensation in my oven***
- \* Steam and condensation is a natural by product of cooking any food with high water content, such as frozen food, chicken etc.
- \* You may get condensation in the oven cavity and forming between the oven door glasses. This is not necessarily a sign that the oven is not working correctly.
- \* Do not leave food in the oven to cool after it has been cooked and the oven has been switched off.
- \* Use a covered container, where practical, when cooking to reduce the amount of condensation that forms.



***IMPORTANT: If your appliance appears not to be operating correctly, then you should disconnect it from your mains supply and then contact Baumatic Customer Care on telephone number (0118) 933 6911.***

***DO NOT ATTEMPT TO REPAIR THE APPLIANCE YOURSELF.***

Please note that if an engineer is asked to attend whilst the product is under guarantee and finds that the problem is not the result of an appliance fault, then you may be liable for the cost of the call out charge.

***The appliance must be accessible for the engineer to perform any necessary repair. If your appliance is installed in such a way that an engineer is concerned that damage will be caused to the appliance or your kitchen, then he will not complete a repair.***

***This includes situations where appliances have been tiled in, sealed in with sealant, have wooden obstructions placed in front of the appliance, like plinths. Or any installation other than the one specified by Baumatic Ltd. has been completed.***

Please refer to the conditions of guarantee that appear on the warranty card that you receive with the appliance.

## Baumatic Consumables

- **BC001** Degreaser for Dishwashers (200 g)
- **BC002** Descaler for Washing Machines and Dishwashers (200 g)
- **BC003** Ceramic Hob Cleaner (250 ml)
- **BC004** Oven Cleaner (250 ml)
- **BC005** Stainless Steel Cleaner and Protector (250 ml)
- **BC007** E-Cloth – General Purpose Cloth
- **BC008** Microwave Cover

To order a Baumatic consumable product please call 0123 5437 244 and quote the product code. You can also order online from [eshop.baumatic.co.uk](http://eshop.baumatic.co.uk)





***United Kingdom***

Baumatic Ltd.,  
Baumatic Buildings,  
6 Bennet Road,  
Reading, Berkshire  
RG2 0QX  
United Kingdom

**Sales Telephone**

(0118) 933 6900

**Sales Fax**

(0118) 931 0035

**Customer Care Telephone**

(0118) 933 6911

**Customer Care Fax**

(0118) 986 9124

**Spares Telephone**

(01235) 437244

**Advice Line Telephone**

(0118) 933 6933

**E-mail:**

sales@baumatic.co.uk  
customercare@baumatic.co.uk  
spares@baumatic.co.uk  
technical@baumatic.co.uk

**Website:**

[www.baumatic.co.uk](http://www.baumatic.co.uk)

**Facebook:**

[www.facebook.com/baumatic.uk](http://www.facebook.com/baumatic.uk)

***Republic of Ireland***

**Service Telephone**

1-890 812 724

**Spares Telephone**

091 756 771

***Czech Republic***

Baumatic CR spol s.r.o.  
Lípová 665  
460 01 Liberec 4  
Czech Republic

+420 483 577 200

[www.baumatic.cz](http://www.baumatic.cz)

***Slovakia***

Baumatic Slovakia, s.r.o.  
Panenská 34  
811 03 Bratislava - Staré Mesto  
Slovakia

+421 255 640 618

[www.baumatic.sk](http://www.baumatic.sk)

***Germany***

Baumatic Gmbh  
Bachstr.10-12  
D-32 257 Bünde  
Deutschland

+49 (0) 5223 99408 0

[www.baumatic.de](http://www.baumatic.de)

***Italy***

Baumatic Italia S.R.L.  
Via Galvani N.3  
35011 Campodarsego (PD)

+3904 9920 2297

[www.baumatic.it](http://www.baumatic.it)

***Holland***

Baumatic Benelux B.V.  
Dukdalfweg 15d  
1332 BH ALMERE  
Nederland

+31(0)36 549 1553

[www.baumatic.nl](http://www.baumatic.nl)





