

BCE1025SS 100 cm
BCE925SS 90 cm
Twin cavity
electric slot-in cooker

INSTRUCTION MANUAL

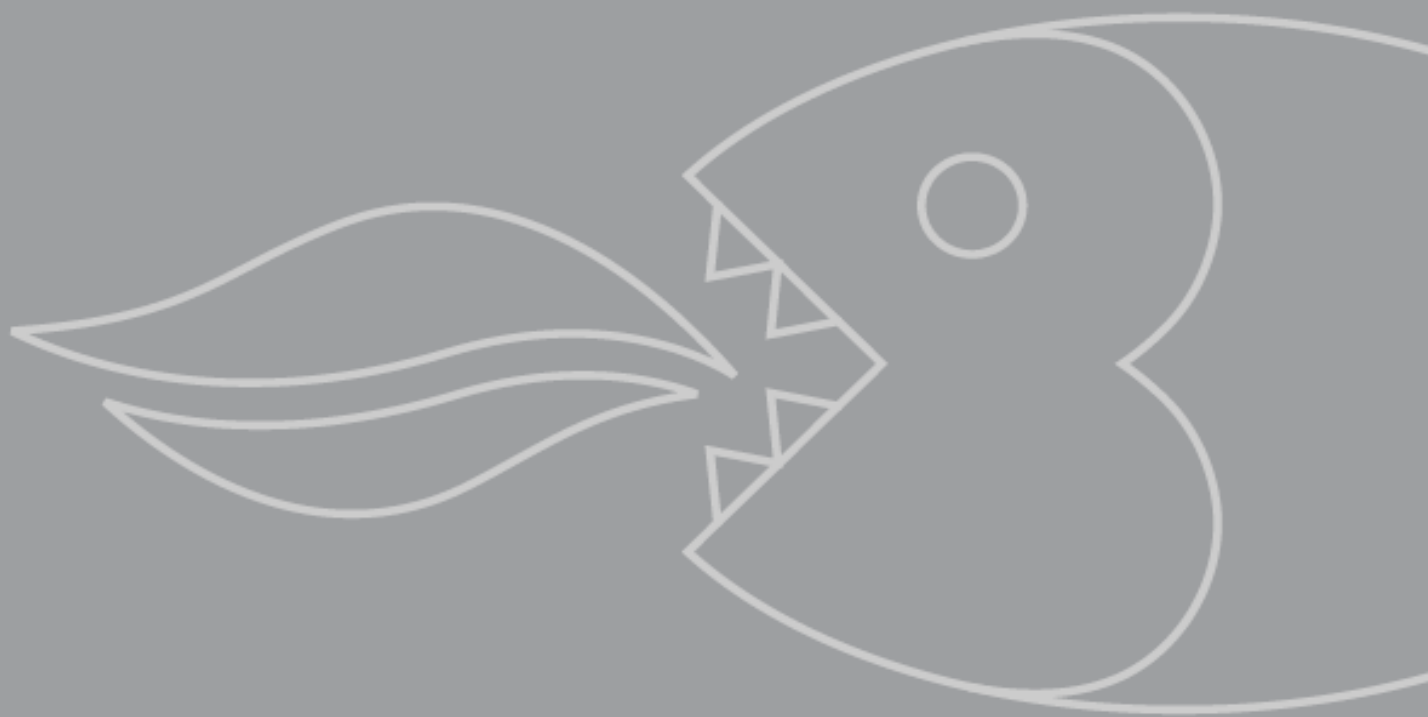

User Manual for your Baumatic

BCE1025SS 100 cm

BCE925SS 90 cm

**Twin cavity electric slot-in
cooker with ceramic top**



NOTE: This User Instruction Manual contains important information, including safety & installation points, which will enable you to get the most out of your appliance. Please keep it in a safe place so that it is easily available for future reference; for you or any person not familiar with the operation of the appliance.

Contents

Environmental note	4
Important safety information	5 – 8
Specifications	9 – 13
Dimensions	9
Specifications	9 - 10
Electrical details	10
Control panel	11 –12
Hob surface layout	13
Oven timer	13
Using the hob top	13 -19
Before first use	13
Selecting a cooking function and temperature	14 -18
Using the main oven	14 -15
Cooking functions	14 -15
Using the secondary oven	15 -16
Cooking guidelines	16
Warnings	17
Using the hob top cooking zones	17 -18
Hob guidelines	18 –19
Cooking tips	20 -22
Cakes and bread	23
Meat	24
Cleaning and maintenance	24 -28
Cleaning the ceramic hob top	25
After each use	25
Cleaning table	26
Replacing the oven bulb	26 –27
Removing the oven door for cleaning	27
Removing the inner door glass for cleaning	28
Installation	29 -33
Positioning	29 -30
Securing the back-guard	31
Fitting the safety chain and hook	31 -32
Electrical connection	32
Connecting the main supply cable	33
My appliance isn't working correctly	34 -36
Baumatic consumables	37
Contact details	38

This appliance is marked according to the European directive 2002/96/EC on Waste electrical and Electronic Equipment (WEEE). By ensuring this product is disposed of correctly, you will help prevent potential negative consequences for the environment and human health, which could otherwise be caused by inappropriate waste handling of this product.

The symbol  on the product, or on the documents accompanying the product, indicates that this appliance may not be treated as household waste. Instead it shall be handed over to the applicable collection point for the recycling of electrical and electronic equipment.

Disposal must be carried out in accordance with local environmental regulations for waste disposal.

For more detailed information about treatment, recovery and recycling of this product, please contact your local city office, your household waste disposal service or the shop where you purchased the product.



- The packaging materials that Baumatic uses are environmentally friendly and can be recycled.
- Please discard all packaging material with due regard for the environment.

Important safety information



Your safety is of the utmost importance to Baumatic. Please make sure that you read this instruction booklet **before** attempting to install or use the appliance. If you are unsure of any of the information contained in this booklet, please contact the Baumatic Customer Care Department.

General Information

- This appliance is designed for domestic household use and for the cooking of domestic foodstuffs.
- **IMPORTANT:** *The adjacent furniture and all materials used in the installation **must** be able to withstand a minimum temperature of 85°C above the ambient temperature of the room it is located in, whilst in use.*
- Certain types of vinyl or laminate kitchen furniture are particularly prone to heat damage or discolouration at temperatures below the guidelines given above.
- Any damage caused by the appliance being installed in contravention of this temperature limit, or by placing adjacent cabinet materials closer than 25 mm to the appliance, **will be the liability of the owner.**
- **IMPORTANT:** *Baumatic Ltd. **DO NOT** recommend that this appliance is installed on any type of marine vessel.*
- The use of this appliance for any other purpose or in any other environment without the express agreement of Baumatic Ltd. will invalidate any warranty or liability claim.
- Your new appliance is guaranteed against electrical or mechanical defects, subject to certain exclusions that are noted in Baumatic's Conditions Of Guarantee. The foregoing does not affect your statutory rights.
- **Repairs may only be carried out by Baumatic service engineers or their authorised service agents.**

Warning and safety instructions

- This appliance complies with all current European safety legislation. Baumatic do wish to emphasise that this compliance does not remove the fact that the appliance surfaces ***will become hot during use and retain heat after operation.***

Child Safety

- Baumatic strongly recommend that babies and young children are prevented from being near to the appliance and not allowed to touch the appliance ***at any time.*** During and after use, all surfaces will become hot.
- If it is necessary for younger family members to be in the kitchen, please ensure that they are kept under close supervision at all times.

General Safety

- ✓ Make sure that you understand the controls before using the appliance.
- ✓ Check that all of the controls on the appliance are turned off after use.
- ✓ Always stand back when opening the oven door, this will allow heat to disperse.
- ✓ Take care when removing items from the oven, as the contents may be hot.
- ✓ Always keep the oven doors closed when the oven is not in use.
- ✓ Always follow the basic principles of food handling and hygiene; this will prevent the possibility of bacterial growth.
- ✓ Always keep ventilation slots clear of obstructions.
- ✓ Keep fingers away from the hinge areas when closing the door, otherwise you may trap them.
- ✓ Oven gloves should be used when placing food in the oven cavity and when removing it. Care should be taken to avoid direct contact with any of the elements in the appliance.
- ***DO NOT LEAVE THE APPLIANCE UNATTENDED WHILST IN USE.***

- **Do not** place heavy objects on the oven door or lean on the oven door when it is open, as this can cause damage to the oven door hinges. Nobody should be allowed to sit or stand on any part of the cooker.
- **Do not** store chemicals, food stuffs, pressurised containers in or on the cooker or in cabinets immediately above or next to the cooker.
- **Do not** heat up unopened food containers, as pressure can build up which may cause the container to burst.
- **Do not** place flammable or plastic items on or near the hob burners, these types of materials should also not be placed in the oven or the compartment below the oven.
- **Do not** leave heated oil or fat unattended, as this is a fire risk. You should not fill a deep fat frying pan more than one third full of fat or oil; you should also not use a lid.
- **Do not** allow fat or oil to build up in the oven trays, grill pan or oven base.
- **Do not** place pans or baking trays directly on the base of the oven cavity, or line it with aluminium foil.
- **Do not** grill food containing fat without using the grill trivet. The grill trivet should never be covered with aluminium foil.
- **Do not** place hot enamel parts in water, leave them to cool first.
- **Do not** allow vinegar, coffee, milk, saltwater, lemon, tomato juice or any liquid with high sugar content to remain in contact with the enamel parts of the appliance. Spillages should be wiped up immediately.
- **Do not** allow electrical fittings or cables to come into contact with areas on the appliance that get hot.
- **Do not** use the appliance to heat the room it is located in or to dry clothing. No clothing should be placed over or near to the hob burners or oven door.
- **Do not** install the appliance next to curtains or soft furnishings.
- **Do not** attempt to lift or move cooking appliances by using the oven door or handle, as this may cause damage to the appliance or result in injury to the person lifting the appliance.

Cleaning

- Cleaning of the oven should be carried out on a regular basis.
- Great care should be taken whilst using this appliance and when following the cleaning procedure.
- ***IMPORTANT: The appliance must be disconnected from the mains before following the cleaning procedure.***
- ***IMPORTANT: Care must be taken when cleaning between the door glasses, and inside the inner frame as some of the edges maybe sharp due to the manufacturing process.***

Installation



This appliance must be correctly installed by a suitably qualified person, strictly in accordance with the manufacturer's instructions. Please see the specific section of this booklet that refers to installation.

- ***Baumatic Ltd. declines any responsibility for injury or damage, to person or property, as a result of improper use or installation of this appliance.***
- Heat, steam and moisture will be created during use of the appliance, take care to avoid injury and ensure that the room is adequately ventilated. If the appliance is going to be used for prolonged periods of time, then additional ventilation may be required.
- Please consult with your qualified installer if you are in any doubt about the amount of ventilation that you will require.

Declaration of conformity

This appliance complies with the following European Directives:

2006/95/EC regarding "low voltage"
2004/108/EC regarding "electromagnetic disturbances"
-89/109/EEC regarding "materials in contact with food".

- The above directives comply with 93/68/EEC regarding CE marking.
- The manufacturer declares that the oven is built using certified materials and requires the appliance to be installed in accordance with the standards currently in force. This appliance must be used by a trained person for domestic purposes only.

Specifications

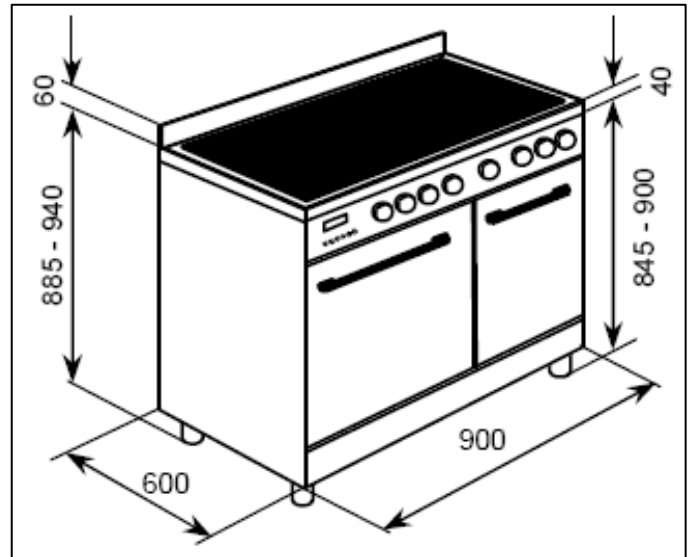
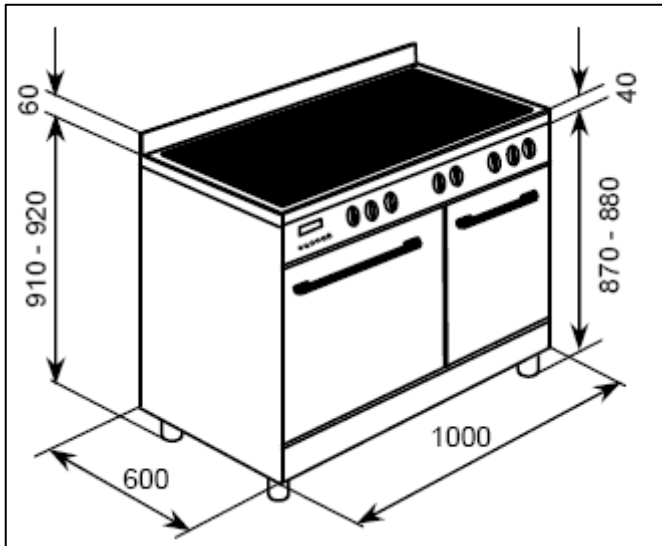

Product dimensions:

BCE1025SS

Height: 910 - 920 mm
Width: 1000 mm
Depth: 600 mm

BCE925SS

Height: 885-940 mm
Width: 900 mm
Depth: 600 mm

Product specifications:

5 zone ceramic hob:

- 2 x 1.20 kW hyper-speed zone (Ø 140 mm)
- 1 x 2.10 kW hyper-speed zone (Ø 210 mm)
- 1 x 1.00/2.20 kW double hyper-speed zone (Ø 140 / 210 mm)
- 1 x 0.80/2.20 kW oval hyper-speed (Ø 170 / 265 mm)

Left oven: Multifunction oven

- 6 functions
- Net oven capacity: 50 litres
- Gross oven capacity: 64 litres

Right oven: Static oven with grill

- 3 functions
- Net oven capacity: 35 litres
- Gross oven capacity: 43.5 litres

Specifications:

- o Energy efficiency class: **A/A**
- o Cooling fan
- o Oven lights
- o Thermostatically controlled grill (main oven)
- o Fixed grill (secondary oven)
- o Double-glazed removable doors
- o Removable full inner glasses
- o Wipe Clean enamelled cavities
- o Adjustable feet

Standard accessories:

- o WipeClean enamelled baking tray with handle
- o WipeClean enamelled baking tray
- o 3 x Safety shelves
- o Removable side racks
- o Trivet
- o Ceramic hob scraper

Optional extra:

- o BPS2 Pizza Stone

Electrical details

Rated Voltage:	220 - 240 Vac 50 Hz
Supply Connection:	55 A (double pole switched fused outlet with 3mm contact gap)
Max Rated Inputs:	12.15 kW
Mains Supply Lead:	3 core x 6 mm ² (not supplied)
Oven Light Bulb:	E14 15 W/300°C screw type pygmy

For future reference please record the following information which can be found on the rating plate and the date of purchase which can be found on your sales invoice. The main rating plate for your oven can be located at the back of the cooker. A smaller rating plate which quotes the serial and model numbers can be found on the inner cavity of the oven or grill door.

Model Number

Serial Number

Date of Purchase

Oven function control knob

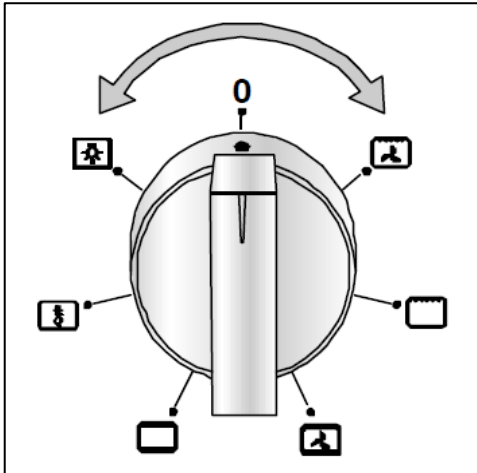

- Use this control knob to select a function for the main oven.

Thermostat control knob (main oven)

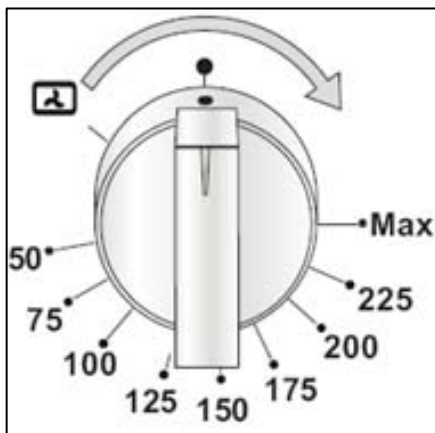

- Use this control knob to control the temperature in the oven.

Thermostat control knob (secondary oven)

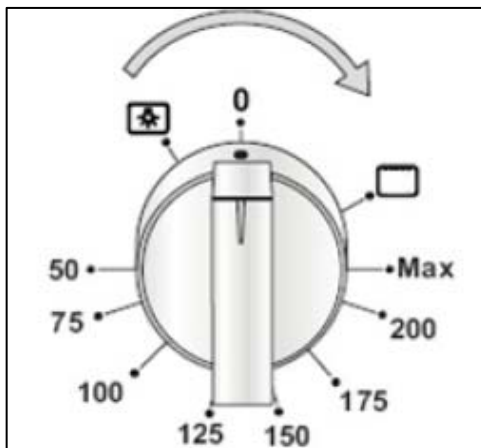

- Rotate this control knob to the grill symbol to select the grill oven function.
- Turn the control knob to the light icon to switch on the oven light and start the conventional oven function. You can then proceed to set the oven temperature.

Hob top cooking zone control knob

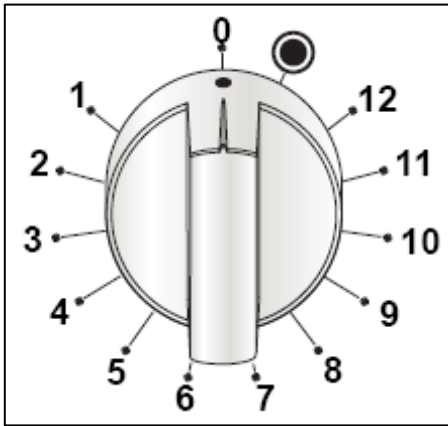

- Use this control knob to control the power level of the chosen cooking zone.

Analogue Thermometer

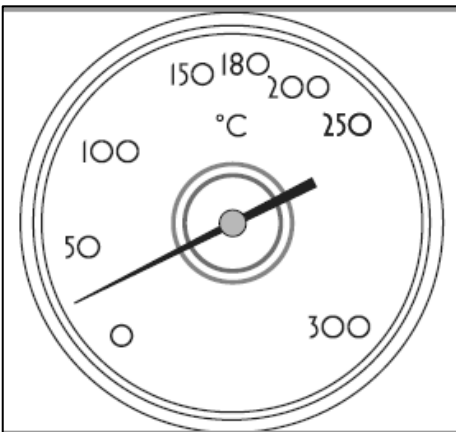

- The control panel has an analogue thermostat which displays the approximate internal temperature of the main oven.

The oven timer (minute-minder)

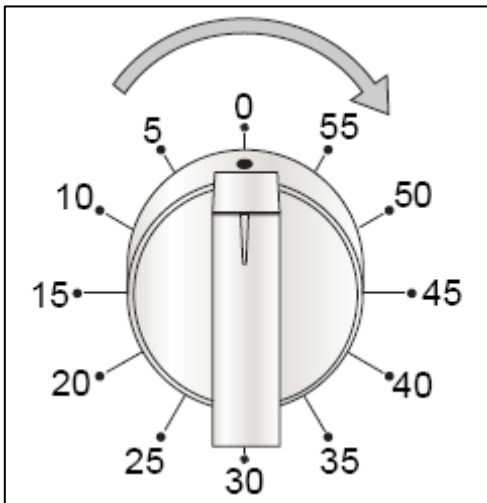

- To set a cooking time, first wind the timer up by turning it completely once from left to right and then back to the number of minutes you require the timer to be set for.
- The timer will sound when the set time has been reached.

Using the hob top

Hob surface layout

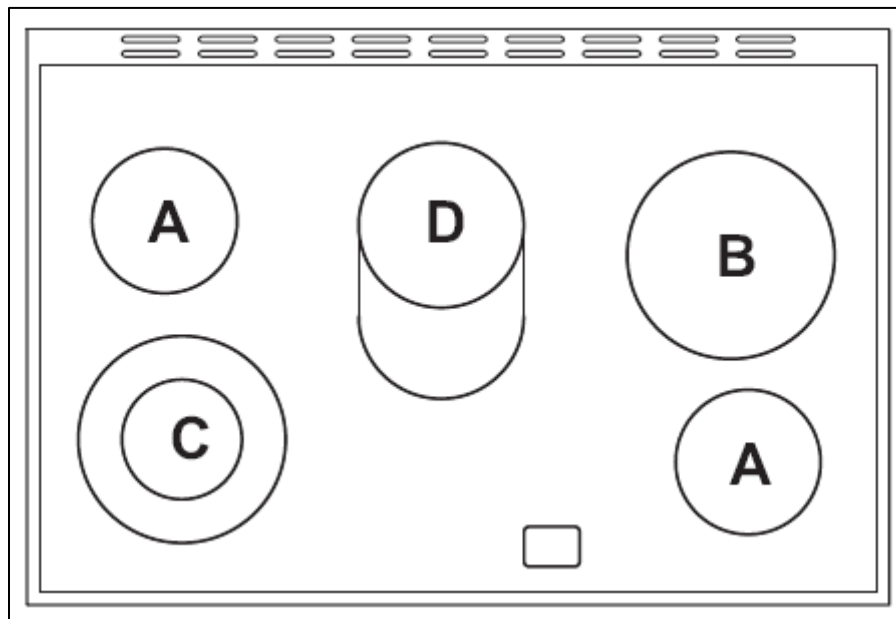

- A)** 1.20 kW hyper-speed zone (Ø 140 mm)
- B)** 2.10 kW hyper-speed zone (Ø 210 mm)
- C)** 1.00 / 2.20 kW double hyper-speed zone (Ø 140 / 210 mm)
- D)** 0.80 / 2.20 kW oval hyper-speed zone (Ø 170 / 265 mm)

Before first use



IMPORTANT: You should clean the hob surface (see "Cleaning and maintenance" section).

- You should switch on one cooking zone at a time, for 5 minutes at the maximum setting. This will help to eliminate any new smell that exists and evaporate any humidity that has formed on the heating elements during transit.
- Do not burn off more than one zone at once.
- **You must** place a saucepan filled half full with cold water on each zone as you burn it off.

Selecting a cooking function and temperature

Using the main oven

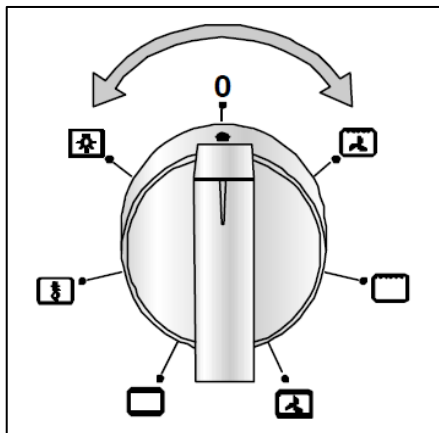

You can rotate this dial in either direction to select an oven function for the main oven.

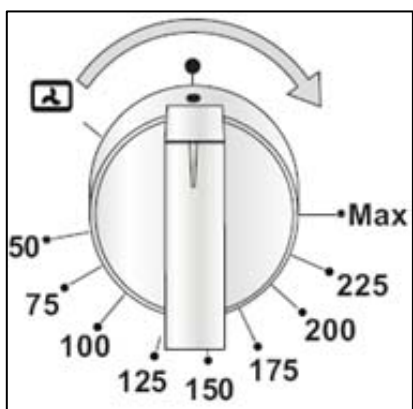

The oven temperature control knob should be turned clockwise to select the oven temperature.

There are six cooking functions available on your appliance:



LIGHT CONTROL: Turn the control knob to this icon to turn the oven light on and off.



DEFROST MODE: The fan runs without heat to reduce the defrosting time of frozen foods. The time required to defrost the food will depend on the room temperature, the quantity and type of food. Always check food packaging for the defrosting instructions.



CONVENTIONAL OVEN: This method of cooking provides traditional cooking, with heat from the top and lower elements. This function is suitable for roasting and baking on one shelf only.



FAN OVEN: This method of cooking uses the top and bottom heating elements with the fan. This results in the heat being evenly distributed in the cavity to cook food simultaneously on different shelves and also prevents the transmission of smells and tastes from one dish to another.



GRILL WITH FAN: This cooking method uses the top element in conjunction with the fan, to help give a fast circulation of heat. Suitable where quick browning is required and “sealing” the juices in, such as with steaks, hamburgers, some vegetables etc.



CENTRE GRILL: This cooking method is normal grilling, utilising the inner part only of the top element, which directs heat downwards onto the food. Suitable for grilling small portions of bacon, toast, meat etc

Using the secondary oven

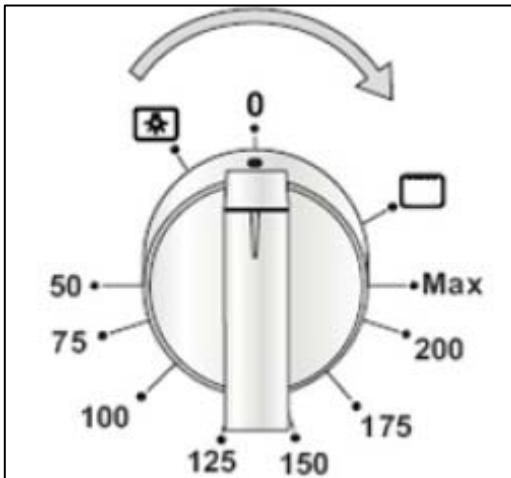

- The control knob should be turned clockwise and used to select the fixed grill function.
- Turn the control dial to the light icon to switch on the oven light and start the conventional oven function. You can then proceed to set a temperature for the oven.

IMPORTANT: The grill door must be closed when using the grill function.



CONVENTIONAL OVEN: This method of cooking provides traditional cooking, with heat from the top and lower elements. This function is suitable for roasting and baking on one shelf only.



FULL GRILL: This method of cooking utilises the inner and outer parts of the top element, which directs heat downwards onto the food. This function is suitable for grilling medium or large portions of sausages, bacon, steaks, fish etc.

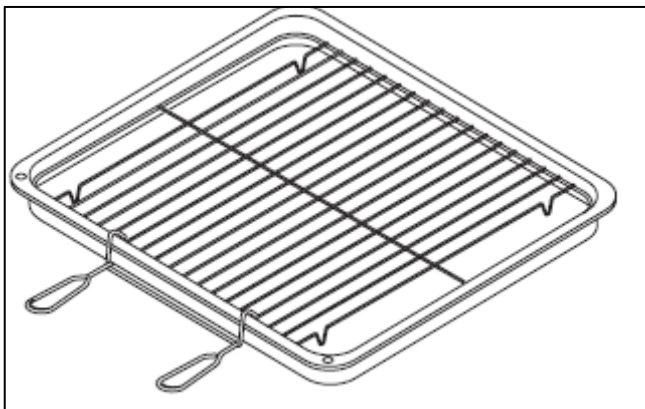

REMEMBER: When using any of the grill functions, it is important to place a drip pan at the base of the oven cavity to collect any juices which may drip down (see image on next page).

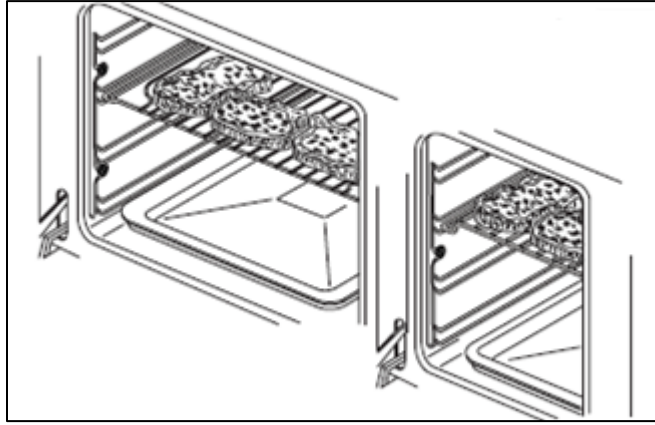

The oven walls of the two cavities are fitted with various guide bars on which you can place an oven shelf or a drip tray (see image below).

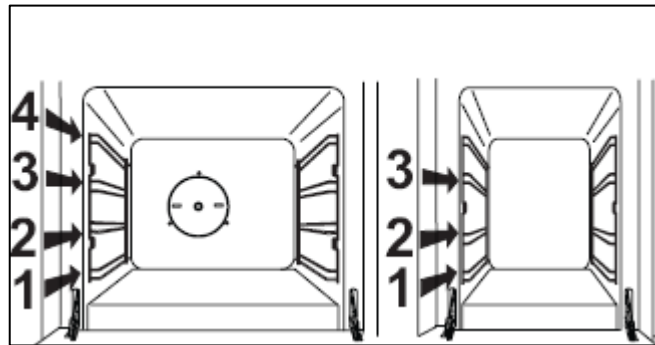

Cooking guidelines

- Please refer to the information given on food packaging for guidance on cooking temperatures and times. Once familiar with the performance of your appliance, temperatures and times can be varied to suit personal preference.
- Make sure that frozen foods are thoroughly thawed before cooking, unless the instructions on the food packaging advise that you can “cook from frozen”.
- You should pre-heat the oven and not place food inside of it until the oven is properly heated. You can choose not to pre-heat when using the fan oven; however you should extend the cooking time given on the food packaging by approximately ten minutes.
- Before cooking, check that any unused accessories are removed from the oven.
- Place cooking trays in the centre of the oven and leave gaps between the trays to allow air to circulate.
- Try to open the door as little as possible to view the dishes.
- The oven light will remain on during cooking.

Warnings

- Keep the oven door closed when using any of the oven functions or the grill cavity.
- Do not use aluminium foil to cover the enamelled baking tray or heat items wrapped in aluminium foil under the grill. The high reflectivity of the foil could potentially damage the grill element.
- You should never line the base of your oven with aluminium foil.
- During cooking, never place pans or cookware directly onto the bottom of the oven. They should always be placed on the shelves provided.
- The grill heating element becomes extremely hot during operation, avoid touching it inadvertently when handling the food which you are grilling.
- **Important:** Be careful when opening the door, to avoid contact with hot parts and steam.
- **IMPORTANT:** In case of fire, switch off the electricity supply to the appliance.
- **NEVER** try to extinguish a fire with water. Switch off the appliance and then cover the flame with a lid or a fire blanket.

Using the hob top zones

- Each zone on the ceramic hob top is controlled by a control knob.
- To activate a zone, rotate the control knob anticlockwise to choose a power level between 1 – 12.

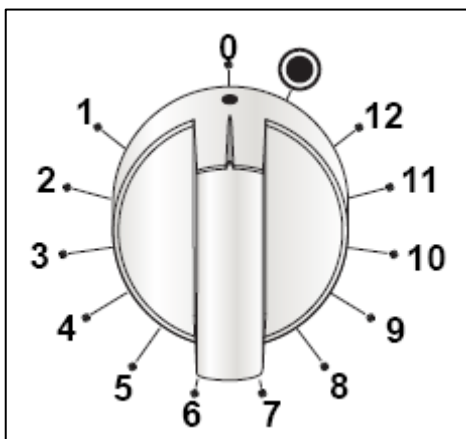

- You should select a control knob position that is suitable for the particular cooking that you are carrying out.
- You should always rotate the control dial anticlockwise to move through power levels 1 – 12. **For the double cooking zones, this will activate the inner section only.**

- For the double cooking zones, if you continue turning the control dial anticlockwise, just past power level 12, to the dual zone symbol, this will activate the outer section as well. In this position, both dual zones are set to maximum power.
- To control the power level of both the inner and outer sections of the double cooking zones, turn the control dial anti-clockwise to the required power level.
- When you have finished cooking on a particular cooking zone, it is important to make sure that the control knob is turned back to 0 (the off position).
- For a general guide for cooking with the different power levels please see the table below.

<i>Power level</i>	<i>Heat intensity</i>	<i>Possible cooking process</i>
0	Off	
1-2	Low	To dissolve butter, chocolate etc. To heat small amounts of liquid.
3-4	Moderate	To heat greater quantities of liquid.
5-6	Slow	Thawing frozen food and preparing stews, boiling or simmering.
7-8	Medium	Bringing foods to boiling point. For delicate roasts and fish.
9-10	Strong	For roasts, chops and steaks. For large amounts of boiled meat.
11-12	Hot	Bringing large amounts of water to the boil. Frying.

Hob guidelines

- The first few times the hob top is used, it may give off an acrid, burning smell. This smell will disappear completely with repeated use.
- The worktop is fitted with cooking areas of different diameter and power.
- The positions where the heat will radiate from are clearly marked on the hob top. The saucepans must be positioned exactly on these zones for efficient heating to occur. Pans should have the same diameter as the cooking zone that they are being used on.

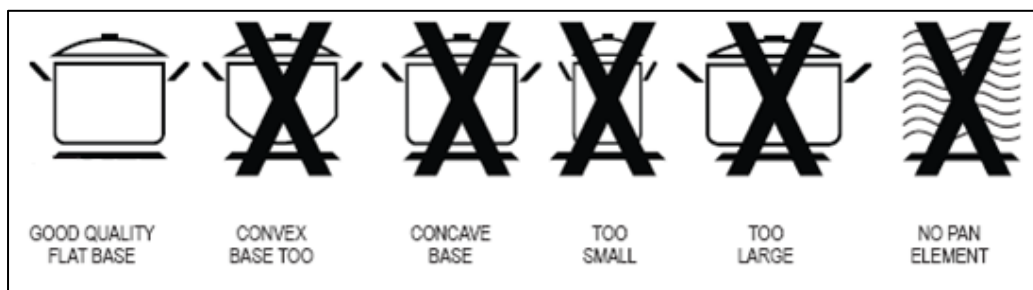

- You should not use saucepans with rough bottoms, as this can scratch the surface.
- Before use, make sure that the bottoms of the saucepans are clean and dry.
- When cold, the bottom of the pans should be slightly concave, as they expand when hot and lie flat on the surface of the hob. This will allow the heat to transfer more easily.
- The best thickness for the bottom of the pans is 2 – 3 mm of enameled steel and 4 – 6 mm for stainless steel with sandwich type bottoms.
- If these rules are not followed, then there will be a great loss of heat and energy. Heat not absorbed by the saucepan, will spread to the hob, frame and surrounding cabinets.
- Preferably cover pans with a lid to permit cooking at a lower heat.
- Always cook vegetables and potatoes, etc. in as little water as possible to reduce cooking times.
- For a faster heat up of a zone, you can turn the control knob to 12. Then when the contents of the saucepan are boiling, you may turn the control knob to a lower setting.
- Food or liquid that has a high sugar content may damage the hob top if it comes into contact with the hob surface. Any spillages should be wiped up immediately, however this may not prevent the hob surface from becoming damaged.
- ***IMPORTANT: The hob surface is tough; however it is not unbreakable and can be damaged. Especially if pointed or hard objects are allowed to fall on it with some force.***
- ***DO NOT USE THE HOB IF THE SURFACE BECOMES BROKEN OR CRACKED – RISK OF ELECTRIC SHOCK. YOU SHOULD SWITCH OFF THE POWER SUPPLY CONTACT THE BAUMATIC SERVICE DEPARTMENT IMMEDIATELY.***

Cooking tips

Cooking table for main oven

<i>Foods</i>	<i>Weight (kg)</i>	<i>Shelf position from bottom</i>	<i>Traditional oven</i>		<i>Combined oven (fan ventilated)</i>	
			<i>Temperature (°C)</i>	<i>Cooking / baking time (mins)</i>	<i>Temperature (°C)</i>	<i>Cooking / Baking time (mins)</i>
Meat loafs						
Roasted veal	1	1-2	200-225	100-120	190	100-120
Roasted beef	1	1-2	200-225	40-50	190	40-50
Roasted pork	1	1-2	200-225	100-120	190	100-200
Roasted lamb	1	1-2	200-225	100-120	190	100-120
Game						
Roast hare	1	1-2	225-MAX	50-60	225-MAX	50
Roast pheasant	1	1-2	225-MAX	60-70	225-MAX	60
Roast partridge	1	1-2	225-MAX	50-60	225-MAX	50
Poultry						
Roasted chicken	1-2	1-2	200-225	80-90	190	70-80
Roasted turkey	1-2	1-2	200-225	100-120	190	90-110
Roasted duckling	2-3	1-2	200-225	90-110	190	80-100
Fish						
Roasted whole fish	1	2	200	30-35	170-190	25-30
Sea bass	1	2	175	20-25	160-170	15-20
Baked pasta						
Lasagne	2.5	2	210-225	60-75	225-MAX	30-40
Cannelloni	2.5	2	210-225	60-75	225-MAX	30-40
Pizza	1	2	225-MAX	25-30	225-MAX	20-25
Bread	1	2	225-MAX	20-25	220	20
Patisserie						
Biscuits in general		2	190	15	170-190	15
Shortcrust pastry		2	200	20	190-200	20
Victoria sponge		2	200	40-45	190-200	40-45
Cakes / Flans						
Angel cake / sponge	0.8	2	190	52	170-190	45
Fruit cake	0.8	2	200	65	190-200	65
Chocolate cake	0.8	2	200	45	190-200	45

The information given in this table is approximate and may vary according to individual needs.

Grilling in main oven

Foods	Weight (kg)	Shelf position from bottom	Traditional oven			Combined oven (fan ventilated)		
			Temperature (°C)	Cooking / Baking time (mins)		Temperature (°C)	Cooking / Baking time (mins)	
				1 st Side	2 nd Side		1 st Side	2 nd Side
Meat								
T-bone steak	0.50	3	225-MAX	15	15	200	10	10
Steak	0.15	3	225-MAX	5	5	200	5	5
Chicken (cut in half)	1	2-3	225-MAX	25	25	200	18	18
Fish								
Trout	0.42	3	225-MAX	18	18	200	10	10
Sea bass	0.40	3	225-MAX	15	15	200	10-12	10-12
Sole	0.20	3	225-MAX	10	10	200	8-9	8-9
Bread								
Toast		3-4	225-MAX	2-3	2-3	200	2-3	2-3

The information in this table is approximate and may vary according to individual needs.

Cooking table for the secondary oven

Conventional oven:

Foods	Weight (kg)	Shelf position from bottom	Temperature (°C)	Cooking / Baking time (mins)
Meat loafs				
Roasted veal	1	1	220	80
Roasted beef	1	1	200-225	40-50
Roasted pork	1	1	220	80
Roasted lamb	1	1	200-225	100-120
Game				
Roast hare	1	1-2	225-MAX	50-60
Roast pheasant	1	1-2	225-MAX	60-70
Roast partridge	1	1-2	225-MAX	50-60
Poultry				
Roasted chicken	1	1-2	200-225	80-90
Roasted turkey	1	1-2	200-225	100-120
Roasted duckling	1	1-2	200-225	90-110
Fish				
Roasted whole fish	1	1-2	200	30-35

Sea bass	1	1-2	175	20-25
Baked pasta				
Lasagne	2.5	1-2	210-225	60-75
Cannelloni	2.5	1-2	210-225	60-75
Pizza	1	2	MAX	20-22
Bread	1	2	MAX	20-25
Patisserie				
Biscuits in general		2	190	20
Shortcrust pastry		2	200	20
Victoria sponge		2	200	40-45
Cakes / Flans				
Angel cake / sponge	0.8	1	190	50
Fruit cake	0.8	1-2	200	65
Chocolate cake	0.8	1-2	200	45

The information in this table is approximate and may vary according to individual needs.

Grilling in secondary oven:

Foods	Weight (kg)	Shelf position from bottom	Cooking / Baking time (mins)	
			1 st Side	2 nd Side
Meat				
T-bone steak	0.50	3	12	12
Steak	0.15	3	5	5
Chicken (cut in half)	1	2-3	25	25
Fish				
Trout	0.42	3	10	10
Sole	0.20	3	10	10
Bread				
Toast		3	3	3

The information in this table is approximate and may vary according to individual needs.

Cooking tips for cakes and bread

- Heat the oven for at least 15 minutes before you start cooking bread or cakes.
- Do not open the door during baking because the cold air will stop the yeast from rising.
- When the cake is cooked turn the oven off and leave it in for about 10 minutes.
- Do not use the enamelled baking tray or drip pan to cook cakes in.
- To test if a cake is cooked, about 5 minutes before the end of cooking time, put a cake tester or skewer in the highest part of the cake. If it comes out clean, the cake is cooked.
- If the cake sinks, next time use less liquid or lower the temperature by 10°C.
- If the cake is too dry, make some tiny holes with a toothpick and pour some drops of fruit juice or spirits on it. The next time, increase the temperature by 10°C and set a shorter cooking time.
- If the cake is too dark on top next time put the cake on a lower shelf and cook it at a lower temperature for longer.
- If the top of the cake is burnt, cut off the burnt layer and cover with sugar or decorate with cream, jam and confectioner's cream.
- If the cake is too dark underneath next time place it on a higher shelf and cook it at a lower temperature.
- If the cake or bread is cooked nicely outside but is still uncooked inside, next time use less liquid and cook at a lower temperature for longer.
- If the cake will not come out of the tin, slide a knife around the edges, place a damp cloth over the cake and turn the tin upside down. Next time, grease the tin well and sprinkle with flour or bread crumbs.
- If the biscuits will not come away from the baking tray, put the tray back in the oven for a while and lift the biscuits up before they cool. The next time use a sheet of baking parchment to prevent this happening again.

Cooking tips for meat

- If, when cooking meat, the time needed is more than 40 minutes, turn the oven off 10 minutes before the end of cooking time to exploit the residual heat and save energy.
- Your roast will be juicer if cooked in a closed pan. It will be crispier if cooked without a lid.
- Normally white meat, poultry and fish need medium temperatures (less than 200°C).
- To cook "rare" red meats, high temperatures (over 200°C) and short cooking times are needed.
- For a tasty roast, lard and spice the meat.
- If your roast is tough, next time leave the meat to ripen longer.
- If your roast is too dark on top or underneath, next time put it on a higher or lower shelf, lower the temperature and cook for longer.
- If your roast is undercooked, cut it in slices and arrange the slices on a baking tray with gravy and finish cooking it.

Cleaning and maintenance



Cleaning operations must only be carried out when the oven is cool.

The appliance should be disconnected from your mains supply before commencing any cleaning process.

- The oven should be thoroughly cleaned before it is operated for the first time and after each use. This will avoid residual food stuffs becoming baked on the oven cavity. After residues have been baked on several times, they are far more difficult to remove.
- ***Never*** clean the oven surfaces by steam cleaning.
- The oven cavity should only be cleaned with warm soapy water, using either a sponge or soft cloth. No abrasive cleaners should be used.

- Any stains that may appear on the bottom of the oven will have originated from food splashes or spilt food, these splashes occur during the cooking process. These could possibly be a result of the food being cooked at an excessively high temperature or being placed in cookware that is too small.
- You should select a cooking temperature that is appropriate for the food that you are cooking. You should also ensure that the food is placed in an adequately sized dish and that you use the enamelled baking tray where appropriate.
- Outer parts of the oven should only be cleaned with warm soapy water, using either a sponge or soft cloth. No abrasive cleaners should be used.
- We would recommend that an appropriate stainless steel cleaner and polish is regularly used on the stainless steel surfaces of this appliance.
- If you use any form of oven cleaner on your appliance, then you must check with the manufacturer of the cleaner that it is suitable for use on your appliance.
- ***Any damage that is caused to the appliance by a cleaning product will not be fixed by Baumatic free of charge, even if the appliance is within the guarantee period.***

Cleaning the ceramic hob top



Any residues that are left on the hob top surface from cleaning agents **will** damage it. You should remove any residues with water and a little washing up liquid.



Abrasive cleaners or sharp objects will damage the hob surface; you should clean it using water and a little washing up liquid.



Although it is easier to clean some deposits whilst the hob surface is still warm. You should take care not to burn yourself if cleaning the hob surface when it is still warm.

After each use

- Wipe the appliance over with a damp cloth and a little washing up liquid.
- Dry the appliance by rubbing the surface with a clean cloth.

Cleaning table

<i>Type of deposit</i>	<i>Remove immediately?</i>	<i>Remove when the appliance has cooled down?</i>	<i>What should I use to remove the deposit?</i>
Sugar or food/liquid containing sugar	Yes	No	Ceramic hob scraper
Tin foil or plastic	Yes	No	Ceramic hob scraper
Fat splashes	No	Yes	Ceramic hob cleaner
Metallic discolourations	No	Yes	Ceramic hob cleaner
Water splashes or water rings	No	Yes	Ceramic hob cleaner

Replacing the oven bulb



IMPORTANT: The oven must be disconnected from your mains supply before you attempt to either remove or replace the oven bulb.

- Draw out the side guide rails in order to provide access to the bulb.

Flat lamps

- Remove the glass protection cap (**C**) from the bulb socket by lifting it with a screwdriver placed between the cap and the oven wall.

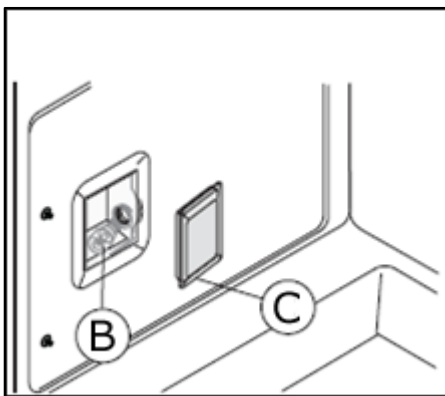

- Replace the bulb (**B**) with a 15 W/300°C, screw type pygmy.
- ***Do not*** use any other type of bulb.
- Screw the lamp cover back into its original position.

Round lamps

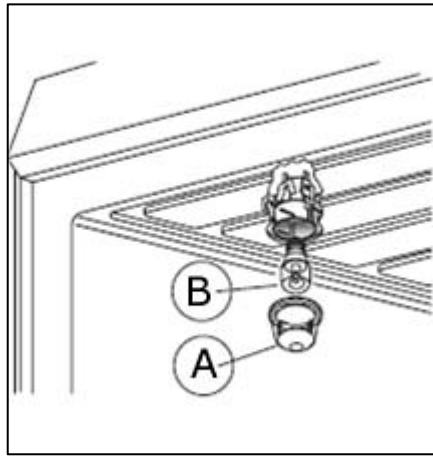

- Turn the glass protection cap **(A)** anti-clockwise and change the lamp **(B)**.
- Refit the cap by screwing it back in a clockwise direction

Removing the oven door for cleaning

- The oven door can be removed to give easier access to the oven when cleaning.
- Open the oven door and insert a rivet or nail **(R)** in the hole **(F)** of the hinge (see image below).

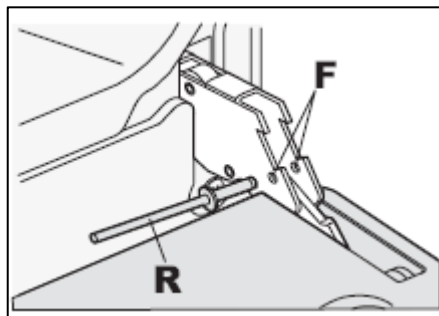

- Partially close the door, forcing it upwards at the same time to free the stop tooth and hinge sector.
- Once the hinge is free, pull the door forwards tilting it slightly upwards to free the sector.
- To reassemble, proceed in the reverse order, playing attention to the correct position of the sectors.

Removing the inner door glass for cleaning

Ensure the top cavity is cold before cleaning.



- Simply open the oven door and remove the support securing the glass. The glass will then slide out easily.
- To replace the glass, follow the first step in reverse.

WARNING: This procedure can be carried out with the door fitted on the appliance but pay attention that when the glass is pulled upwards, the force of the hinges can close the door roughly.

- ***IMPORTANT:*** You should make sure that the door is supported at all times and that you place the door on some padded material whilst cleaning it.
- The oven door and door glass should only be cleaned using a damp cloth and a small amount of detergent. The cloth ***MUST NOT*** have come into contact with any form of cleaning product or chemical previously.

Installation



The installation must be carried out by a suitably qualified person, in accordance with the current version of the following.

- *UK Regulations and Safety Standards or their European Norm Replacements.*
- *Building Regulations* (issued by the Department of the Environment).
- *Building Standards* (issued by the Scottish Development Department).
- *IEE Wiring Regulations.*
- *Electricity At Work Regulations.*
- *Gas Safety (Installation and Use) (Amendment) Regulations.*

Positioning



The adjacent furniture and all materials used in the installation must be able to withstand a minimum temperature of 85°C above the ambient temperature of the room it is located in, whilst in use.

- Your appliance is heavy, so you should be careful when moving or positioning it.
- **Do not** try to move the cooker by pulling on either the door, handle or control panel.

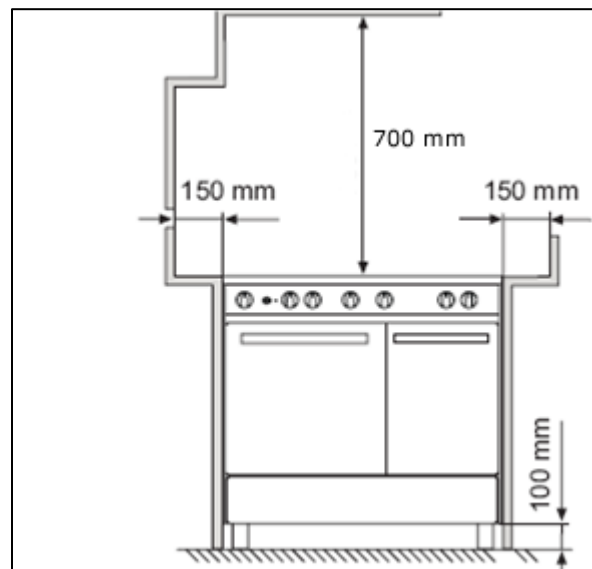

- It can also be used as freestanding, with a cabinet to one side, in a corner setting or with its back to a wall.

- **IMPORTANT:** It should not be installed at the end of a run of cabinets, if there is a cabinet at immediate right angles to the cooker door.
- The wall behind the cooker and 450 mm above and across the width of the cooker should be an incombustible material and preferably an easy clean surface, such as ceramic tiles.
- Any overhanging surface or cooker hood should be **at least 700 mm** above the highest point on the hob top (including the burners).
- Baumatic do not recommend that the cooker is positioned below wall cupboards, as the heat and steam from the appliance and what is being cooked, may damage the cupboard and its contents.
- The cooker may be located in a kitchen, or a bedroom, but not in a room containing a bath or shower. **The cooker must not be installed in a bedroom of less than 20m³ in size.**

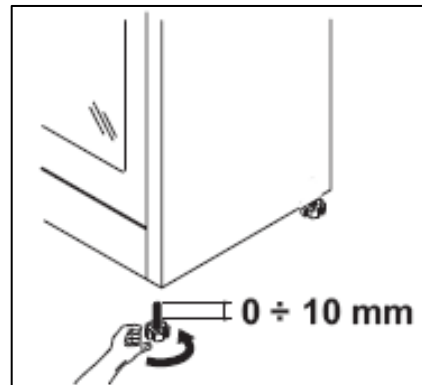
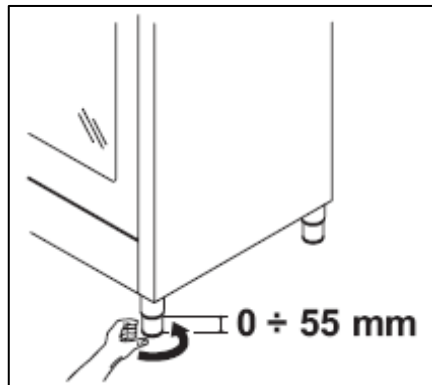

- The cooker is fitted with four legs that can be adjusted to match the height of your kitchen cabinets.
- If the cooker is not level or is unstable due to an uneven floor surface, use the adjustable feet to alter each corner until the cooker is level.
- To assemble them it is necessary to raise the cooker and to screw the four legs into position, on each corner of the base of the appliance.
- **IMPORTANT:** They must be screwed clockwise into position and not just slotted into the holes on each corner. You must screw them through the brackets that are also provided.

Securing the back-guard

- In order to attach the back-guard (**A**) to the appliance, you need to loosen the screws (**B**) positioned on the back of the hob (see image below).

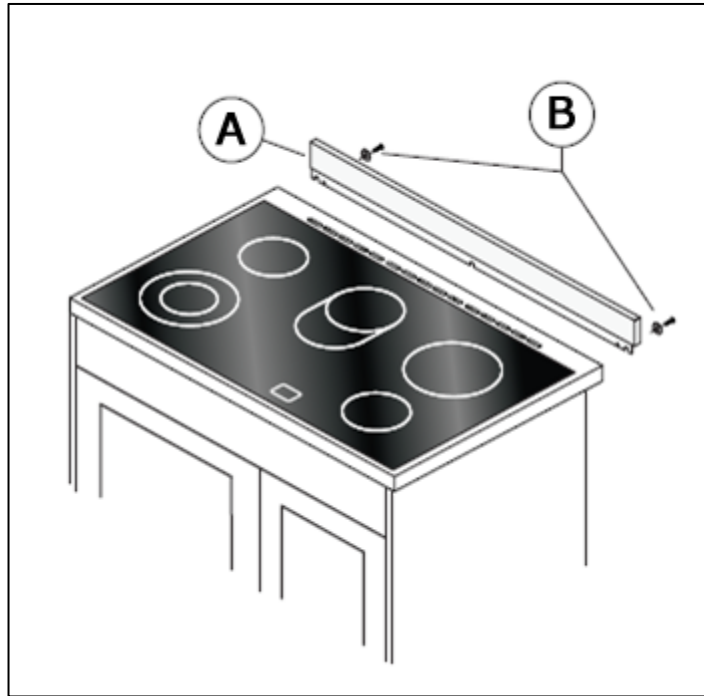

- Fix the back-guard into place by screwing the screws back into the hob with the back-guard placed in between.

Fitting the safety chain and hook

- To prevent the cooker from tipping forward, two lengths of chain **MUST BE** fixed to the back of the oven which should be secured to the hook provided at all times.
- The hook should be secured to the wall at the back of the cooker. The chains should always be attached to the upper hook when the cooker is in position against the wall.
- Attach the chain to the lower hook if the cooker is installed with a hose assembly so that there is no strain on the hose when the cooker is pulled forward for cleaning or maintenance.

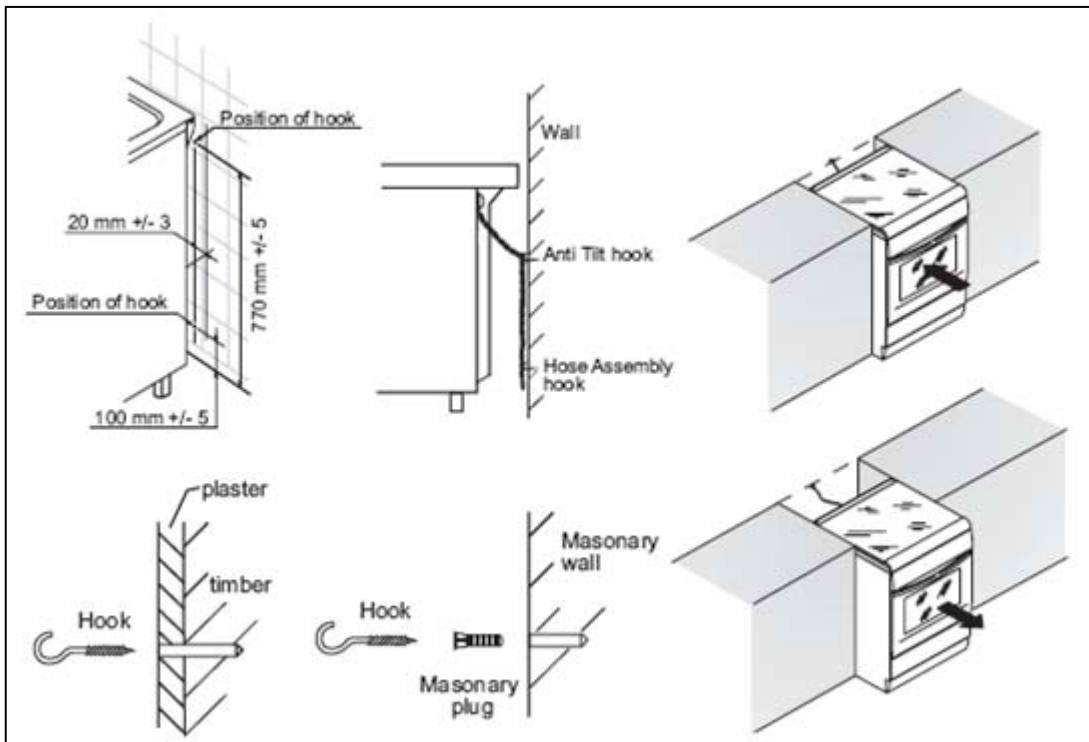

- Fix the upper hook into the wall immediately behind and to the left hand side about 770 mm from the floor.
- Secure the chain to the hook before using or cleaning the oven.
- To prevent strain on the flexible hose assembly, a lower chain and hook can be fixed approximately 100 mm up from the floor.

Electrical connection



This appliance must be installed by a qualified person in accordance with the latest edition of the I.E.E. Regulations and in compliance with Baumatic's instructions.

Before connecting the appliance, make sure that the supply voltage marked on the rating plate corresponds with your mains supply voltage.

WARNING: THIS APPLIANCE MUST BE EARTHED.

- This appliance must be wired into a 55 A double pole switched fused spur outlet, having 3 mm contact separation and placed in an easily accessible position adjacent to the appliance. It should not be located above the appliance and no more than 1.25m away from it.
- The spur outlet must still be accessible even when your oven is located in its operating position.
- Cable type: H05 RRF 3 core x 6 mm²

Connecting the mains supply cable

IMPORTANT

The wires in the mains lead are coloured in accordance with the following code:

GREEN AND YELLOW
BLUE
BROWN

EARTH
NEUTRAL
LIVE

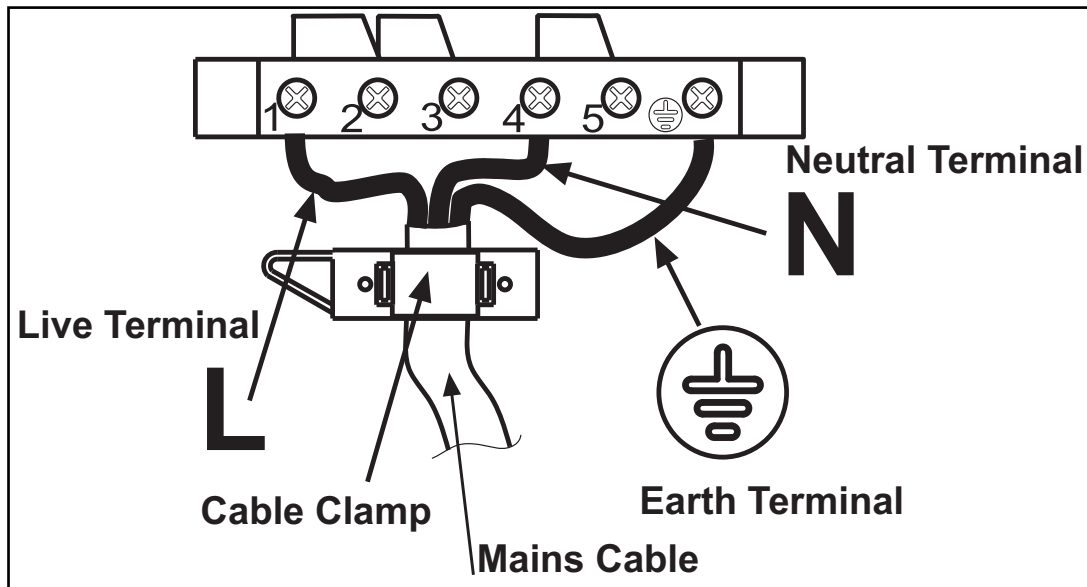

- Connect to the mains terminal block as shown in the image above. It is accessed by removing the cooker back panel.
- The power cable must be laid so that no parts of it ever reach a temperature of 75°C.
- For connecting do not use adapters or shunts as they could cause false contacts resulting in hazardous overheating.
- When connecting directly to the mains, install a multi-polar switch that can withstand the appliance load, with a minimum opening between the contacts of 3 mm.

My appliance isn't working correctly

- ***The oven isn't coming on.***
 - * Check that the oven is in manual operation mode.
 - * Check that you have selected a cooking function and a cooking temperature.
- ***There appears to be no power to the oven and grill.***
 - * Check that the appliance has been connected to the electrical mains supply correctly.
 - * Check that the mains fuses are in working order.
 - * Check that the operating instructions for setting the time of day and putting the appliance into manual operation mode have been followed.
- ***The grill function works but the main oven does not.***
 - * Check that you have used the correct control knob to switch on the oven.
- ***The grill and top oven element is not working, or cuts out for long periods of time during use.***
 - * Allow the oven to cool for approximately 2 hours. Once cool, check whether the appliance is again working properly.
- ***My food is not cooking properly***
 - * Ensure that you are selecting the correct temperature and the correct cooking function for the food that you are cooking. It may be appropriate to adjust your cooking temperature by plus or minus 10°C, to achieve the best cooking results.
- ***My food is not cooking evenly***
 - * Check that the oven has been installed correctly and is level.
 - * Check that the correct temperatures and shelf positions are being used.

- ***The oven light is not working***
 - * Refer the "Replacing the oven bulb" section.

- ***I am getting condensation in my oven***
 - * Steam and condensation is a natural by product of cooking any food with high water content, such as frozen food, chicken etc.
 - * You may get condensation in the oven cavity and forming between the oven door glasses. This is not necessarily a sign that the oven is not working correctly.
 - * Do not leave food in the oven to cool after it has been cooked and the oven has been switched off.
 - * Use a covered container, where practical, when cooking to reduce the amount of condensation that forms.
 - * Steam and condensation may appear from the vent at the rear of the appliance when cooking food with high water content. This is normal and any excess should be wiped away.



IMPORTANT: If your appliance appears not to be operating correctly, then you should disconnect it from your mains supply and then contact Baumatic Customer Care on telephone number (0118) 933 6911.

DO NOT ATTEMPT TO REPAIR THE APPLIANCE YOURSELF.

Please note that if an engineer is asked to attend whilst the product is under guarantee and finds that the problem is not the result of an appliance fault, then you may be liable for the cost of the call out charge.

The appliance must be accessible for the engineer to perform any necessary repair. If your appliance is installed in such a way that an engineer is concerned that damage will be caused to the appliance or your kitchen, then they will not complete a repair.

This includes situations where appliances have been tiled in, sealed in with sealant, have wooden obstructions placed in front of the appliance, like plinths. Or any installation other than the one specified by Baumatic Ltd. has been completed.

Please refer to the conditions of guarantee that appear on the warranty card that you receive with the appliance.

IMPORTANT: Baumatic Ltd. operates a policy of continuous improvement and reserves the right to adjust and modify its products without prior notification.

Baumatic Consumables

- **BC001** Degreaser for Dishwashers (200 g)
- **BC002** Descaler for Washing Machines and Dishwashers (200 g)
- **BC003** Ceramic Hob Cleaner (250 ml)
- **BC004** Oven Cleaner (250 ml)
- **BC005** Stainless Steel Cleaner and Protector (250 ml)
- **BC007** E-Cloth – General Purpose Cloth
- **BC008** Microwave Cover

To order a Baumatic consumable product please call 0123 5437 244 and quote the product code. You can also order online from eshop.baumatic.co.uk



United Kingdom

Baumatic Ltd
Baumatic Buildings,
6 Bennet Road,
Reading, Berkshire
RG2 0QX
United Kingdom

Sales Telephone

(0118) 933 6900

Sales Fax

(0118) 931 0035

Customer Care Telephone

(0118) 933 6911

Customer Care Fax

(0118) 986 9124

Spares Telephone

(01235) 437244

Advice Line Telephone

(0118) 933 6933

E-mail:

sales@baumatic.co.uk
customercare@baumatic.co.uk
spares@baumatic.co.uk
technical@baumatic.co.uk

Website:

www.baumatic.co.uk

Facebook:

www.facebook.com/baumatic.uk

Republic of Ireland

Service Telephone

1-890 812 724

Spares Telephone

091 756 771

Czech Republic

Baumatic CR spol s.r.o.
Lipová 665
460 01 Liberec 4
Czech Republic

+420 483 577 200

www.baumatic.cz

Slovakia

Baumatic Slovakia, s.r.o.
Panenská 34
811 03 Bratislava - Staré Mesto
Slovakia

+421 255 640 618

www.baumatic.sk

Germany

Baumatic Gmbh
Bachstr.10-12
D-32 257 Bünde
Deutschland

+49 (0) 5223 99408 0

www.baumatic.de

Italy

Baumatic Italia S.R.L.
Via Galvani N.3
35011 Campodarsego (PD)

+3904 9920 2297

www.baumatic.it

Holland

Baumatic Benelux B.V.
Dukdalfweg 15d
1332 BH ALMERE
Nederland

+31(0)36 549 1553

www.baumatic.nl

