

BCG625-SS/W/BL/R/IV

**60 cm Twin cavity gas
cooker**

INSTRUCTION MANUAL

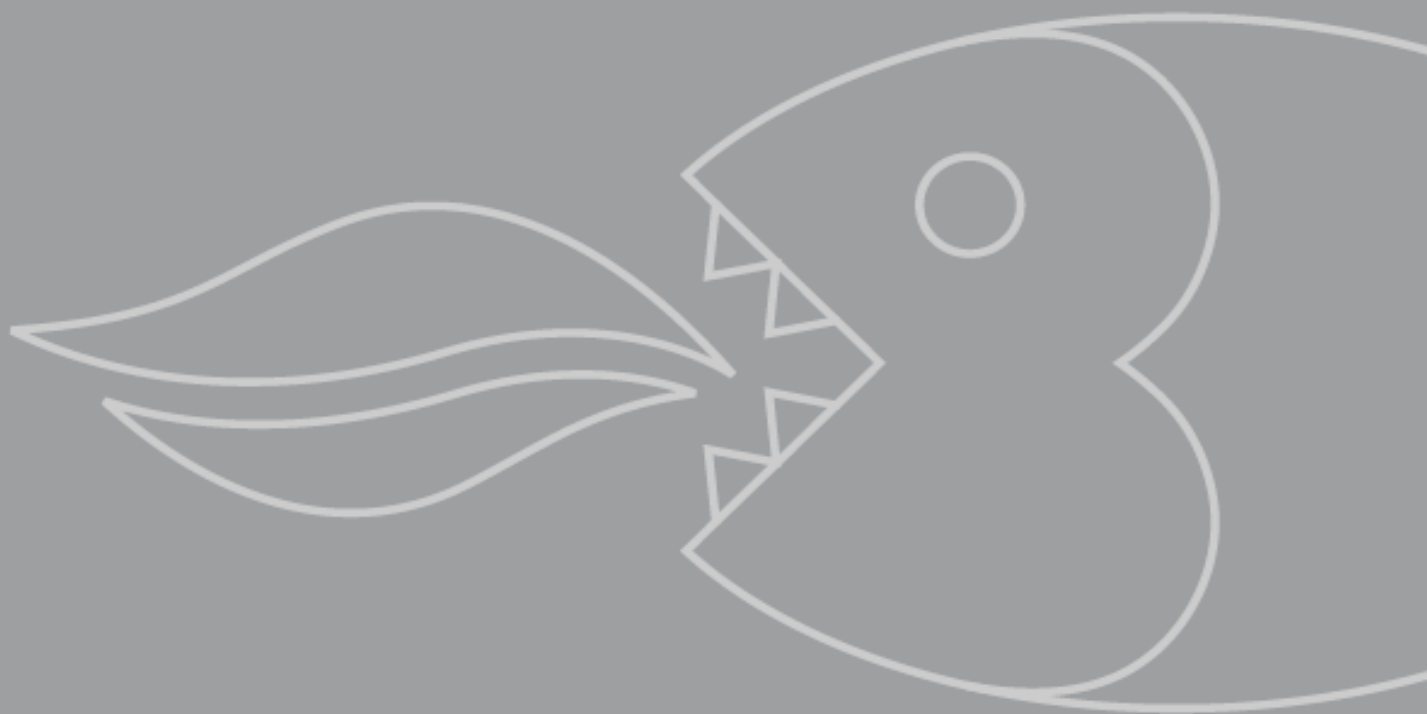

User Manual for your Baumatic

BCG625-SS/W/BL/R/IV

60 cm Twin cavity gas cooker



NOTE: This User Instruction Manual contains important information, including safety & installation points, which will enable you to get the most out of your appliance. Please keep it in a safe place so that it is easily available for future reference; for you or any person not familiar with the operation of the appliance.

JW 20/05/13

Contents

Environmental note	4
Important safety information	5 – 8
Specifications	9 – 12
Dimensions	9
Product specifications	9
Standard accessories	10
Electrical details	10
Gas details	10
Product features	10
Control panel	11 - 12
Oven timer	12
Setting and using the oven programmer/timer	13
Setting the time of day	13
Setting the minute minder function	13
Using the oven	14 - 17
Before first use	14
Using the main oven	15
Base burner appliances	16
Using the grill	17
Cooking guidelines	18
Warnings	18
Using the hob top	19 – 20
Before first use	19
Using the hob top zones	19
Hob guidelines	20
Cleaning and maintenance	20 – 24
Cleaning the gas hob top	21
After each use	21
Cleaning the burners	22
Cleaning the oven	22
Replacing the oven bulb	23
Removing the oven door for cleaning	23 - 24
Installation	24 - 37
Positioning	24 - 26
Ventilation requirements	26
Safety chain anchors	26 - 27
Securing the safety chains	27
Electrical connection	28 - 29
Gas connection	29
Gas safety	30
Gas connection	30 - 31
Gas adjustment (conversion to LPG for the hob top)	32
Minimum flow adjustment for hob gas taps	33
Gas adjustment (conversion to LPG for the oven and grill)	34 - 35
Minimum flow adjustment for the oven and grill burners	35 - 37
My appliance isn't working correctly	37 - 39
Baumatic consumables	40
Contact details	43

This appliance is marked according to the European directive 2002/96/EC on Waste electrical and Electronic Equipment (WEEE). By ensuring this product is disposed of correctly, you will help prevent potential negative consequences for the environment and human health, which could otherwise be caused by inappropriate waste handling of this product.

The symbol  on the product, or on the documents accompanying the product, indicates that this appliance may not be treated as household waste. Instead it shall be handed over to the applicable collection point for the recycling of electrical and electronic equipment.

Disposal must be carried out in accordance with local environmental regulations for waste disposal.

For more detailed information about treatment, recovery and recycling of this product, please contact your local city office, your household waste disposal service or the shop where you purchased the product.



- The packaging materials that Baumatic uses are environmentally friendly and can be recycled.
- Please discard all packaging material with due regard for the environment.

Important safety information



Your safety is of the utmost importance to Baumatic. Please make sure that you read this instruction booklet **before** attempting to install or use the appliance. If you are unsure of any of the information contained in this booklet, please contact the Baumatic Advice Line.

General Information

- This appliance is designed for domestic household use and for the cooking of domestic foodstuffs.
- **IMPORTANT:** *The adjacent furniture and all materials used in the installation **must** be able to withstand a minimum temperature of 85°C above the ambient temperature of the room it is located in, whilst in use.*
- Certain types of vinyl or laminate kitchen furniture are particularly prone to heat damage or discolouration at temperatures below the guidelines given above.
- **IMPORTANT:** *Baumatic Ltd. **DO NOT** recommend that this appliance is installed on any type of marine vessel.*
- The use of this appliance for any other purpose or in any other environment without the express agreement of Baumatic Ltd. will invalidate any warranty or liability claim.
- Your new appliance is guaranteed against electrical or mechanical defects, subject to certain exclusions that are noted in Baumatic's Conditions Of Guarantee. The foregoing does not affect your statutory rights.
- **Repairs may only be carried out by Baumatic service engineers or their authorised service agents.**

Warning and safety instructions

- This appliance complies with all current European safety legislation. Baumatic do wish to emphasise that this compliance does not remove the fact that the appliance surfaces **will become hot during use and retain heat after operation.**

- This appliance is not intended for use by persons (including children) with reduced physical, sensory or mental capabilities, or lack of experience and knowledge, unless they have been given supervision or instruction concerning use of the appliance by a person responsible for their safety.

Child Safety

- Baumatic strongly recommend that babies and young children are prevented from being near to the appliance and not allowed to touch the appliance **at any time**. During and after use, all surfaces will become hot.
- If it is necessary for younger family members to be in the kitchen, please ensure that they are kept under close supervision at all times.

General Safety

- ✓ Make sure that you understand the controls before using the appliance.
- ✓ Check that all of the controls on the appliance are turned off after use.
- ✓ Always stand back when opening the oven door, this will allow heat to disperse.
- ✓ Take care when removing items from the oven, as the contents may be hot.
- ✓ Always keep the oven doors closed when the oven is not in use.
- ✓ Always follow the basic principles of food handling and hygiene; this will prevent the possibility of bacterial growth.
- ✓ Always keep ventilation slots clear of obstructions.
- ✓ Keep fingers away from the hinge areas when closing the door, otherwise you may trap them.
- ✓ Oven gloves should be used when placing food in the oven cavity and when removing it. Care should be taken to avoid direct contact with any of the elements in the appliance.
- ***DO NOT LEAVE THE APPLIANCE UNATTENDED WHILST IN USE.***

- **Do not** place heavy objects on the oven door or lean on the oven door when it is open, as this can cause damage to the oven door hinges. Nobody should be allowed to sit or stand on any part of the cooker.
- **Do not** store chemicals, food stuffs, pressurised containers in or on the cooker or in cabinets immediately above or next to the cooker.
- **Do not** heat up unopened food containers, as pressure can build up which may cause the container to burst.
- **Do not** place flammable or plastic items on or near the hob burners, these types of materials should also not be placed in the oven or the compartment below the oven.
- **Do not** leave heated oil or fat unattended, as this is a fire risk. You should not fill a deep fat frying pan more than one third full of fat or oil; you should also not use a lid.
- **Do not** allow fat or oil to build up in the oven trays, grill pan or oven base.
- **Do not** place pans or baking trays directly on the base of the oven cavity, or line it with aluminium foil.
- **Do not** grill food containing fat without using a grill trivet. The grill trivet should never be covered with aluminium foil.
- **Do not** place hot parts in water, leave them to cool first.
- **Do not** allow vinegar, coffee, milk, saltwater, lemon, tomato juice or any liquid with high sugar content to remain in contact with the enamel parts of the appliance. Spillages should be wiped up immediately.
- **Do not** allow electrical fittings or cables to come into contact with areas on the appliance that get hot.
- **Do not** use the appliance to heat the room it is located in or to dry clothing. No clothing should be placed over or near to the hob burners or oven door.
- **Do not** install the appliance next to curtains or soft furnishings.
- **Do not** attempt to lift or move cooking appliances by using the oven door or handle, as this may cause damage to the appliance or result in injury to the person lifting the appliance.

Cleaning

- Cleaning of the oven should be carried out on a regular basis.
- Great care should be taken whilst using this appliance and when following the cleaning procedure.
- **IMPORTANT:** *The appliance must be disconnected from the mains before following the cleaning procedure.*
- **IMPORTANT:** *Care must be taken when cleaning between the door glasses, and inside the inner frame as some of the edges maybe sharp due to the manufacturing process.*

Installation



This appliance must be correctly installed by a suitably qualified person, strictly in accordance with the manufacturer's instructions. Please see the specific section of this booklet that refers to installation.

- ***Baumatic Ltd. declines any responsibility for injury or damage, to person or property, as a result of improper use or installation of this appliance.***
- Heat, steam and moisture will be created during use of the appliance, take care to avoid injury and ensure that the room is adequately ventilated. If the appliance is going to be used for prolonged periods of time, then additional ventilation may be required.
- Please consult with your qualified installer if you are in any doubt about the amount of ventilation that you will require.

Declaration of conformity

This appliance complies with the following European Directives:

- 73/23/EEC regarding "low voltage"
- 89/336/EEC regarding "electromagnetic disturbances"
- 89/109/EEC regarding "materials in contact with food".
- The above directives comply with 93/68/EEC regarding CE marking.
- The manufacturer declares that the oven is built using certified materials and requires the appliance to be installed in accordance with the standards currently in force. This appliance must be used by a trained person for domestic purposes only.

Specifications

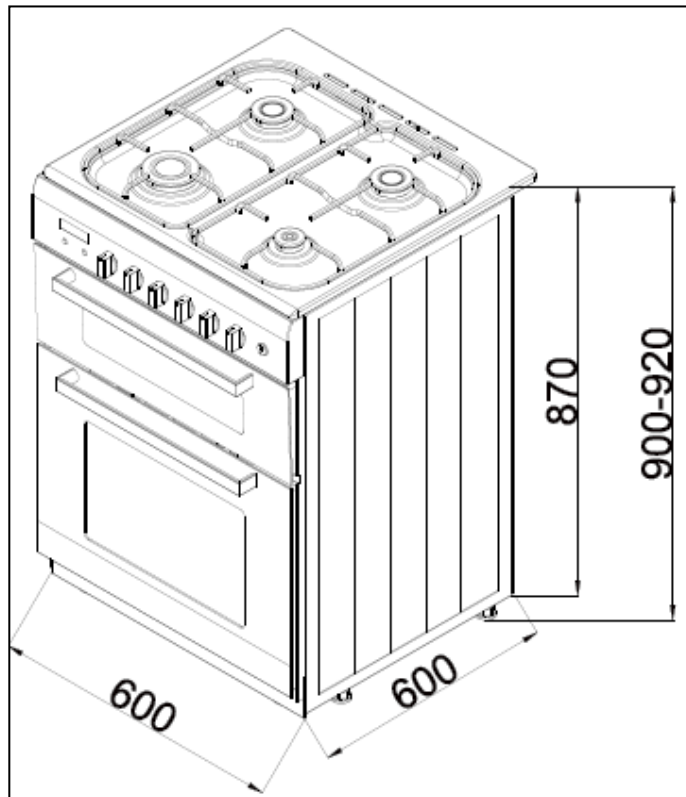

Product dimensions:

Height: 900 - 920 mm
Width: 600 mm
Depth: 600 mm

Product specifications:

- **4 zone gas hob:**
 - 1 x 3.00 kW rapid burner
 - 2 x 1.75 kW semi-rapid burner
 - 1 x 1.00 kW auxiliary burner
 - Enamelled pan stands
 - Push button ignition
 - **Flame failure safety device on all burners**

- Main oven gross / net capacity: 70 / 58 litres
- Top oven gross / net capacity: 32 / 28 litres
- LED minute minder
- Thermostatically controlled grill
- Heat deflector
- Pushbutton ignition
- Double-glazed removable doors
- Adjustable feet
- **Flame failure safety device on oven and grill**

Standard accessories

- 2 x Enamelled baking tray with handle
- 2 x Wire shelves
- 1 x Trivet
- LPG conversion jets

Electrical details

Rated Voltage:	220 - 240 Vac 50 Hz
Supply Connection:	3A (double pole switched fused outlet with 3mm contact gap)
Max Rated Inputs:	0.030 kW
Mains Supply Lead:	3 core x 1.5 mm ²
Oven Light Bulb:	E14 15 W/300°C screw type pygmy

Gas details

Gas Connection Type:	1/2" BSP
Gas Type (Natural Gas):	20 mbar

Product features

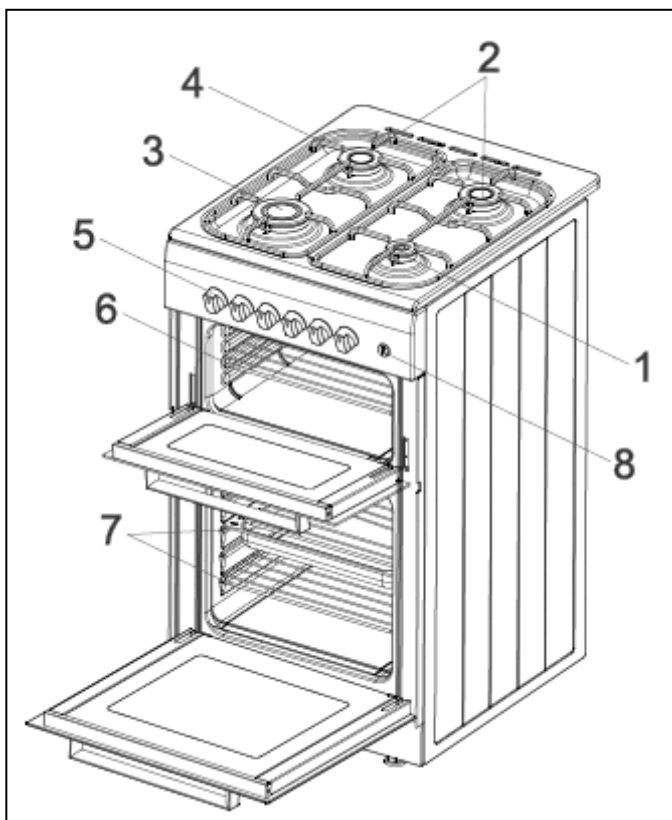

- 1) 1.00 kW auxiliary burner
- 2) 1.75 kW semi-rapid burners
- 3) 3.00 kW rapid burner
- 4) Pan stand
- 5) Control knob
- 6) Grill pan
- 7) 2 x wire shelves
- 8) Igniter and light control

For future reference please record the following information which can be found on the rating plate and the date of purchase which can be found on your sales invoice. The rating plate for your oven can be located on the front frame of the oven cavity.

Model Number

Serial Number

Date of Purchase

Control Panel

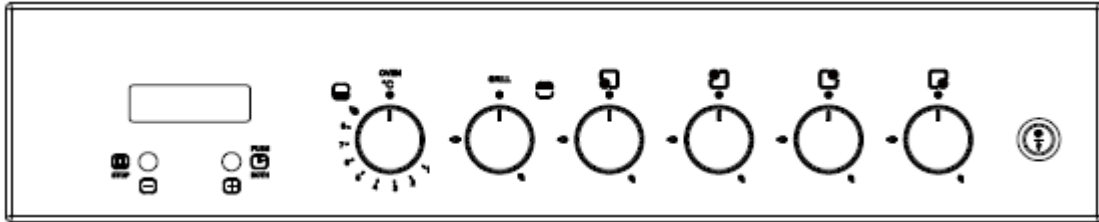

Oven control knob (main oven)

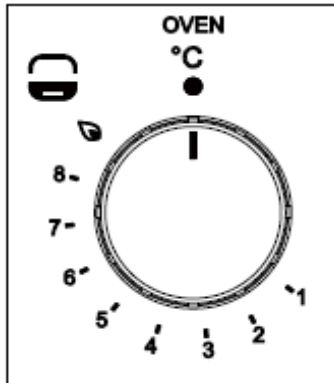

- Use this control knob to control the temperature in the oven.

Grill control knob (top cavity)

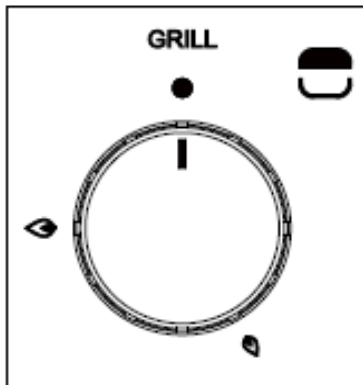

- Use this control knob to select the grill intensity in the secondary oven.

Thermostat control knob (hob)

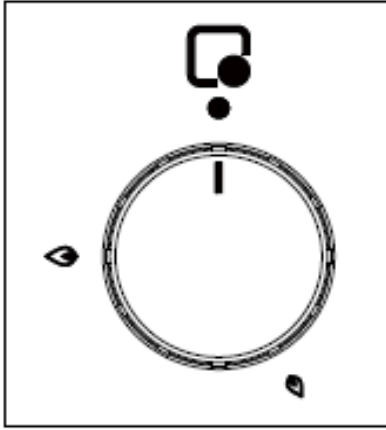

- Use the control knob of the relevant cooking zone to set the temperature intensity.

Oven light / gas ignition

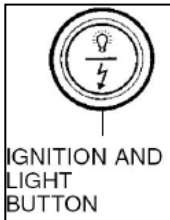

- Use this switch to turn the oven light on and off, and to ignite the gas hobs or the gas ovens.

Oven timer

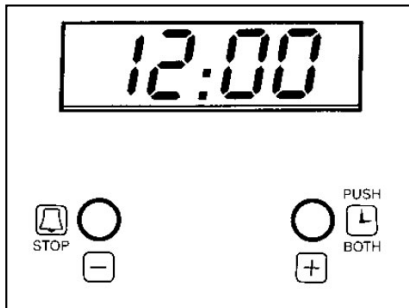

- 1) Alarm stop icon (press minus button to stop alarm).



- 2) Timer minus button.



- 3) Timer plus button.



- 4) Time-setting mode indicator (press plus and minus buttons together to enter this mode).

Setting and using the oven programmer/timer

Setting the time of day

Before using the oven for the first time you should set the time of day.

- Press the plus **(3)** and minus **(2)** buttons simultaneously to enter the time-setting mode. The display will automatically show "12.00".
- Use the plus **(3)** and minus **(2)** buttons to adjust the time to the correct hour. Release all buttons and after a few seconds the time will be set.

Setting the minute minder function (main oven and grill)

You are able to set the minute minder at any time, regardless of whether an oven function has been selected. You can set a period of time using the minute minder function and an alarm will sound when this period of time has elapsed.

- Press the plus button to enter the minute minder mode.
- Continue pressing the plus button until the required cooking time is shown on the display. Release all buttons and after approximately five seconds the countdown will begin.
- At the end of the countdown an alarm will sound. Press the minus button once to silence the alarm.
- ***Important:*** *The oven will continue to heat once the alarm has been silenced. If you have finished cooking, then you should turn the thermostat control knob to 0*

Using the oven

Before first use

- To remove any residue from the oven that may have been left from the manufacturing process, you should select the main oven, and the grill, and turn the thermostat dial to its maximum temperature setting.
- ***IMPORTANT: You should not burn off both oven cavities simultaneously.***
- It is perfectly normal for a smell to be produced during this process.
- You should make sure that any windows in the room are left open during this process.
- It is advisable for you not to remain in the room whilst the burning off process is taking place.
- You should leave each oven on maximum setting for 30 – 40 minutes.
- After both cavities have cooled, they should then be cleaned with warm soapy water, using either a sponge or soft cloth. No abrasive cleaners should be used.
- Outer parts of the oven should be cleaned with warm soapy water, using either a sponge or soft cloth. No abrasive cleaners should be used.
- We would recommend that an appropriate stainless steel cleaner and polish is regularly used on the stainless steel surfaces of this appliance (***BCG625SS only***).

Using the main oven

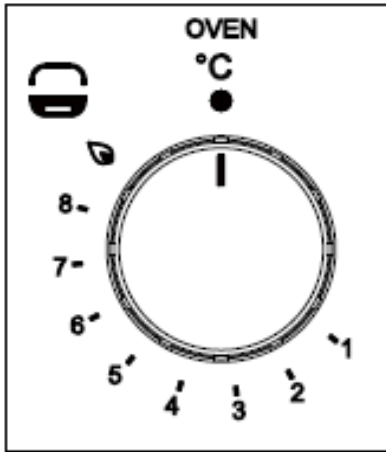

- To turn the main oven on, press and turn the control dial to the large flame position.

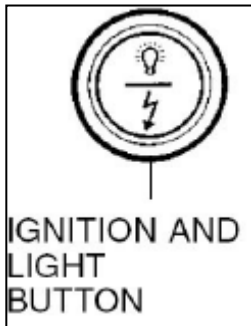

- While still holding the dial inwards, press and hold the bottom half of the ignition button until the oven burner ignites.
 - If the flame goes out, repeat all the steps above keeping the dial pressed in for about five seconds longer.
- Once the burner is lit, turn the knob to a setting from 1 to 8 to set the temperature.
 - The table below shows what setting you should select for the corresponding oven temperature:

Setting	1	2	3	4	5	6	7	8
Temp (°C)	130	140	150	170	190	230	245	250

- The oven light can be turned on anytime by pressing the top half of the ignition button. Press this button again to switch the light off.
- The oven has a flame failure safety device to ensure that no gas escapes if the flames are extinguished. There is also a thermal cut-off which prevents the oven from overheating if the temperature exceeds safety limits.

You should not place food inside the cavity, until the correct cooking temperature has been reached.

Base burner appliances

IMPORTANT: *Your appliance is a Continental style/base burner gas oven, please follow the guidance below, to achieve the best cooking results.*

- There are two different types of heating methods for gas ovens, traditional U.K. style and Continental style.
- In U.K. style gas ovens, the hot air moves around the oven and the hottest part of the cavity is at the top.
- In Continental style gas ovens, the heat source is underneath the base of the oven, which means that the hottest part of the cavity is at the bottom.
- Your oven is a Continental style gas oven, which may require some adjustment in your cooking method, if you are used to a U.K. style gas oven.
- We would recommend that you place the enamelled baking tray into the lowest shelf position.
- This will deflect some of the fierce heat generated by the base burner away from the food that you are cooking.
- This will allow food to cook all of the way through, without getting burnt on the base.
- You may also need to make small adjustments to the cooking temperature and cooking times that you normally used previously.

Using the grill

IMPORTANT: You should always grill with the oven door open. NEVER attempt the grill with the door closed.

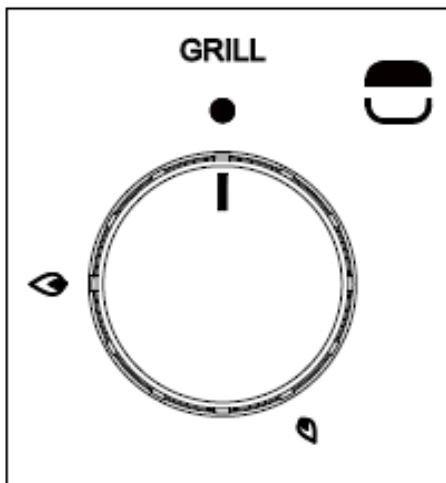

- To turn the grill on press and turn the control dial to the large flame position.

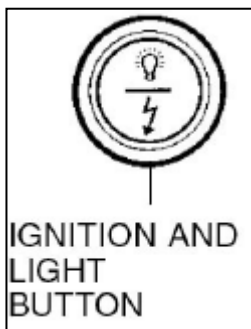

- While still holding in the control knob, press and hold the bottom half of the ignition button until the grill burner ignites.
- For a high heat temperature, leave the control on the large flame symbol. To set a lower heat level, turn the control dial to the small flame position.
- You can turn the light on any time by pressing the bottom half of the ignition button. Press this button again to turn the light off.
- The grill has a flame failure safety device. This ensures that no gas escapes if the flames are extinguished. There is also a thermal cut-off which prevents the grill from overheating if the temperature exceeds safety limits.
- Always remember to use the handle when removing the grill pan and **do not leave the grill unattended while in use.**
- Your grill comes fitted with a heat deflector, which helps prevent the control knobs becoming hot from the heat rising from the front of the grill cavity.

CAUTION: The heat deflector can get very hot during use. Avoid touching the heat deflector until the grill has cooled down. DO NOT allow children to touch the cooker when in use as exterior parts can become hot.

Cooking guidelines

- Please refer to the information given on food packaging for guidance on cooking temperatures and times. Once familiar with the performance of your appliance, temperatures and times can be varied to suit personal preference.
- Make sure that frozen foods are thoroughly thawed before cooking, unless the instructions on the food packaging advise that you can “cook from frozen”.
- You should pre-heat the oven and not place food inside of it until it is properly heated.
- Before cooking, check that any unused accessories are removed from the oven.
- Place cooking trays in the centre of the oven and leave gaps between the trays to allow air to circulate.
- Try to open the door as little as possible to view the dishes.

Warnings

- During cooking, never place pans or cookware directly onto the bottom of the oven. They should always be placed on the shelves provided.
- The grill heating element becomes extremely hot during operation, avoid touching it inadvertently when handling the food which you are grilling.
- ***Important:*** Be careful when opening the door, to avoid contact with hot parts and steam.
- ***IMPORTANT:*** In case of fire, close the main valve of the gas supply and switch off the electricity supply to the appliance. ***NEVER*** pour water onto burning oil.

Using the hob top

Before first use



IMPORTANT: You should clean the hob surface.
(Please see "Cleaning and maintenance" section).

- You should switch on one cooking zone at a time, for 5 minutes at the maximum setting. This will help to eliminate any new smell that exists and evaporate any humidity that has formed on the heating elements during transit.
- Do not burn off more than one zone at once.
- **You must** place a saucepan filled half full with cold water on each zone as you burn it off.

Using the hob burners

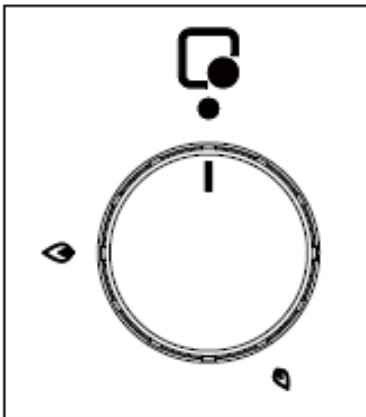

- Each zone on the gas hob top is controlled by a control knob.
- To turn on a cooking zone use the relevant control knob for the zone you wish to use.
- Press and turn the control knob to the large flame position.

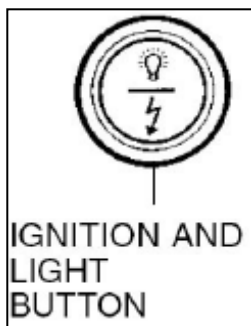

- While still pressing in the control knob, press and hold the bottom half of the ignition button until the burner ignites.
 - For a maximum temperature keep the dial turned to the large flame position.
 - For simmering, lower the heat by turning the control dial to the small flame position.
- *Always remember to turn the control knob to the off position when cooking is completed.*

Hob guidelines

- The diameter of the bottom of the pan should correspond to that of the burner.

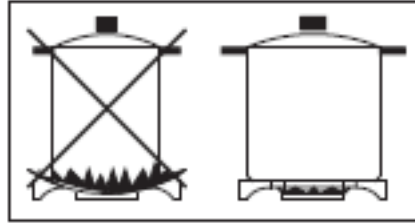

- The burner flame must never extend beyond the diameter of the pan.
- Use flat bottomed pans only
- When possible, keep a lid on the pan whilst cooking.
- Cook vegetables with as little water as possible, to reduce cooking times.

IMPORTANT: Always place pans centrally over the hob burners and position them so that the handles cannot get accidentally caught or knocked off. You should also make sure that the handle is not over one of the other hob burner flames.

Cleaning and maintenance



Cleaning operations must only be carried out when the oven is cool.

The appliance should be disconnected from your mains supply before commencing any cleaning process.

- The oven should be thoroughly cleaned before it is operated for the first time and after each use. This will avoid residual food stuffs becoming baked on the oven cavity. After residues have been baked on several times, they are far more difficult to remove.
- ***Never*** clean the oven surfaces by steam cleaning.
- The oven cavity should only be cleaned with warm soapy water, using either a sponge or soft cloth. No abrasive cleaners should be used.

- Any stains that may appear on the bottom of the oven will have originated from food splashes or spilt food, these splashes occur during the cooking process. These could possibly be a result of the food being cooked at an excessively high temperature or being placed in cookware that is too small.
- You should select a cooking temperature that is appropriate for the food that you are cooking. You should also ensure that the food is placed in an adequately sized dish and that you use the enamelled baking tray where appropriate.
- Outer parts of the oven should only be cleaned with warm soapy water, using either a sponge or soft cloth. No abrasive cleaners should be used.
- We would recommend that an appropriate stainless steel cleaner and polish is regularly used on the stainless steel surfaces of this appliance (**BCG625SS only**).
- If you use any form of oven cleaner on your appliance, then you must check with the manufacturer of the cleaner that it is suitable for use on your appliance.
- ***Any damage that is caused to the appliance by a cleaning product will not be fixed by Baumatic free of charge, even if the appliance is within the guarantee period.***

Cleaning the gas hob top

- Remove the dirty pan supports from the hob and place in warm soapy water for some time. Then wash and dry before replacing.

After each use

- Wipe the appliance over with a damp cloth and a little washing up liquid.
- Dry the appliance by rubbing the surface with a clean cloth.

Cleaning the burners

- Gas burners should be cleaned regularly and after each spillage to remove cooking residues and dirt.

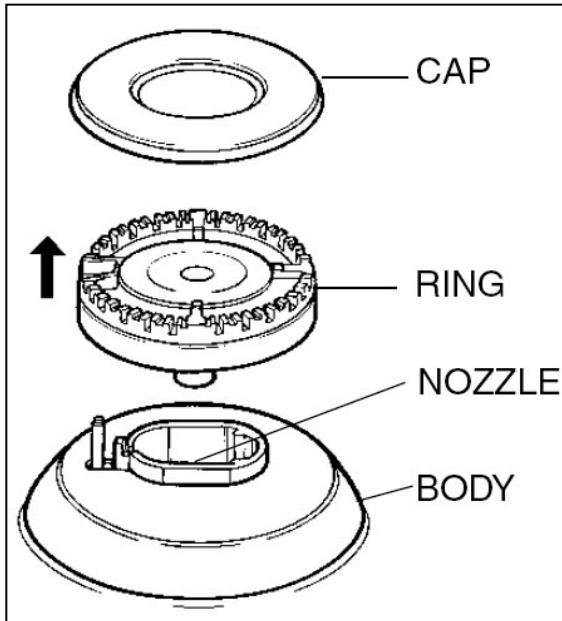

- To clean the burners, remove the caps and rings and place them separately in warm soapy water. After cleaning them, check that the burner ports are clear.
- The body near the nozzle should always be clean. Dirt accumulating around the nozzle may clog it, as a result of which the burner will not light or will light only with a small flame. To clean the nozzle use a brush soaked in solvent.

- Dry all the elements of the burner carefully as wet elements may not light properly. Assemble the clean and dry burners carrying out the disassembly steps in reverse order.

Cleaning the oven

- The oven compartment is coated with vitreous enamel. To clean particularly difficult burnt spots a special oven cleaning agent may be used. However, as these agents are caustic, be careful when using them and follow the manufacturer's guidelines.

***Warning: Do not steam pressure clean the oven.
Always wait until the oven cools down before cleaning.***

Replacing the oven bulb



IMPORTANT: *The oven must be disconnected from your mains supply before you attempt to either remove or replace the oven bulb.*

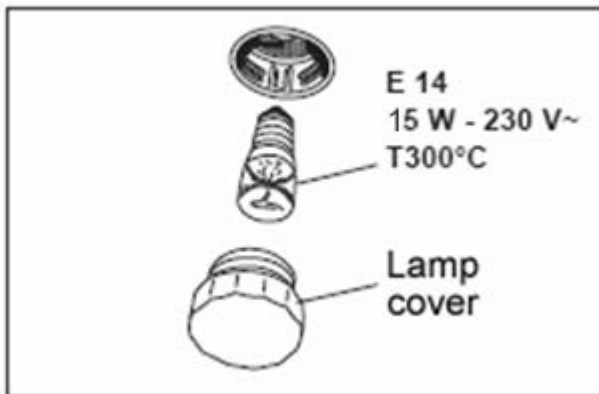

- Remove all oven shelves and the drip tray.
- Unscrew the lamp cover.
- Unscrew the bulb and remove it from its holder.
- Replace the bulb with a 15 W/300°C, screw type pygmy.

- **Do not** use any other type of bulb.
- Screw the lamp cover back into its original position.

Removing the oven door for cleaning

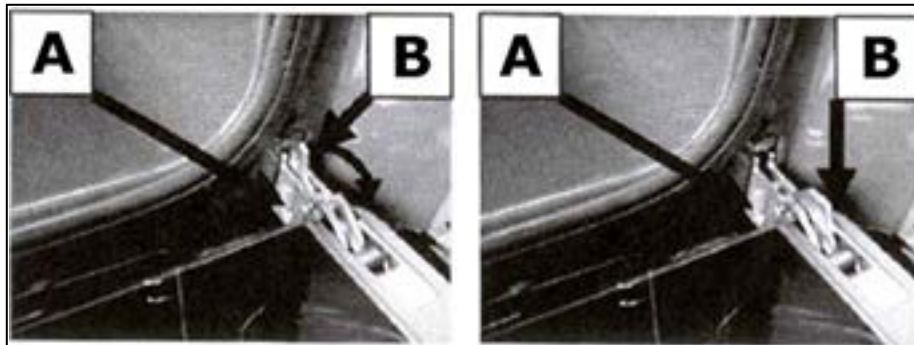

To facilitate the cleaning of the inside of the cooker and the outer frame of the oven, the door can be removed as follows: -

- The hinges **(A)** have two movable bolts on them **(B)**.
- If you raise both of the movable bolts **(B)**, then the hinges **(A)** are released from the oven housing.
- You should grip the sides of the door at the centre and then incline it slightly towards the cooker cavity and then pull it gently away from the cooker cavity.
- **IMPORTANT:** *You should make sure that the door is supported at all times and that you place the door on some padded material whilst cleaning it.*

- The oven door and door glass should only be cleaned using a damp cloth and a small amount of detergent. The cloth **MUST NOT** have come into contact with any form of cleaning product or chemical previously.
- To refit the door you should slide the hinges back into their slots and open the door fully.
- **IMPORTANT:** *The movable bolts (B) must be closed back into their original positions before closing the door.*



- **Take care not to dislodge the hinge locking system when removing the door, as the hinge mechanism has a strong spring.**
- **Do not immerse the door in water at any time.**

Installation



The installation must be carried out by a suitably qualified person, in accordance with the current version of the following.

- ***UK Regulations and Safety Standards or their European Norm Replacements.***
- ***Building Regulations*** (issued by the Department of the Environment).
- ***Building Standards*** (issued by the Scottish Development Department).
- ***IEE Wiring Regulations.***
- ***Electricity At Work Regulations.***
- ***Gas Safety (Installation and Use) (Amendment) Regulations.***

Positioning



The adjacent furniture and all materials used in the installation must be able to withstand a minimum temperature of 85°C above the ambient temperature of the room it is located in, whilst in use.

- Your appliance is heavy, so you should be careful when moving or positioning it.

- **Do not** try to move the cooker by pulling on either the door, handle or control panel.

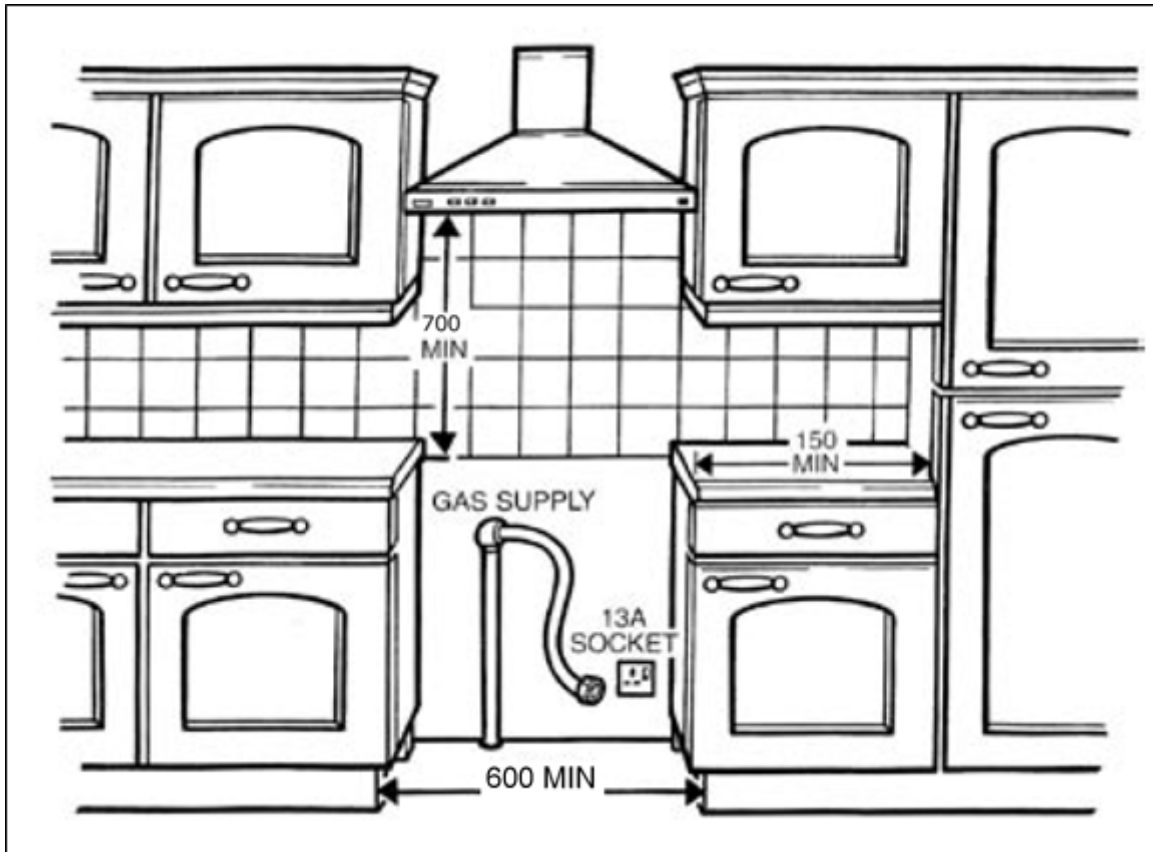

- The cooker is designed to slot in between 600 mm deep cabinets, which are spaced approximately 600 mm apart.
- It can also be used as freestanding, with a cabinet to one side, in a corner setting or with its back to a wall.
- **IMPORTANT:** It should not be installed at the end of a run of cabinets, if there is a cabinet at immediate right angles to the cooker door.
- The wall behind the cooker and 450 mm above and across the width of the cooker should be an incombustible material and preferably an easy clean surface, such as ceramic tiles.
- Any overhanging surface or cooker hood should be **at least 700 mm** above the highest point on the hob top (including the burners).
- Baumatic do not recommend that the cooker is positioned below wall cupboards, as the heat and steam from the appliance and what is being cooked, may damage the cupboard and its contents.

- The cooker may be located in a kitchen, or a bedroom, but not in a room containing a bath or shower. **The cooker must not be installed in a bedroom of less than 20m³ in size.**

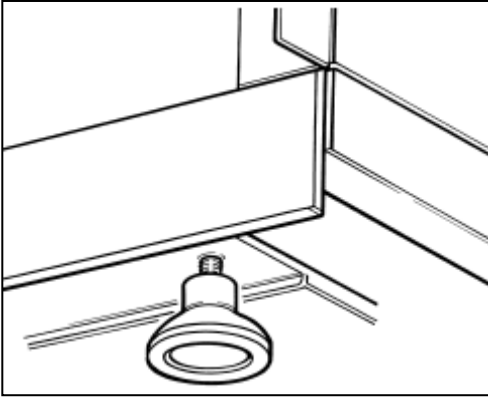

- The cooker is fitted with four feet that can be adjusted to match the height of your kitchen cabinets.
- If the cooker is not level or is unstable due to an uneven floor surface, use the adjustable feet to alter each corner until the cooker is level.

Ventilation requirements

- The room containing the appliance should have an air supply in accordance with BS 5440: Part 2.
- For room volumes up to 5m³ an air vent of 100cm² is required.
- If the room has a door that opens directly to the outside, or the room exceeds 10m³ no air vent is required.
- For room volumes between 5m³ and 10m³ an air vent of 50cm² is required.

Safety chain anchors

- In order to eliminate the risk of the oven falling forward, two chains have been installed at the rear of the cooker. Before use, these will need to be fastened securely to the wall behind the appliance with the anchor brackets supplied.

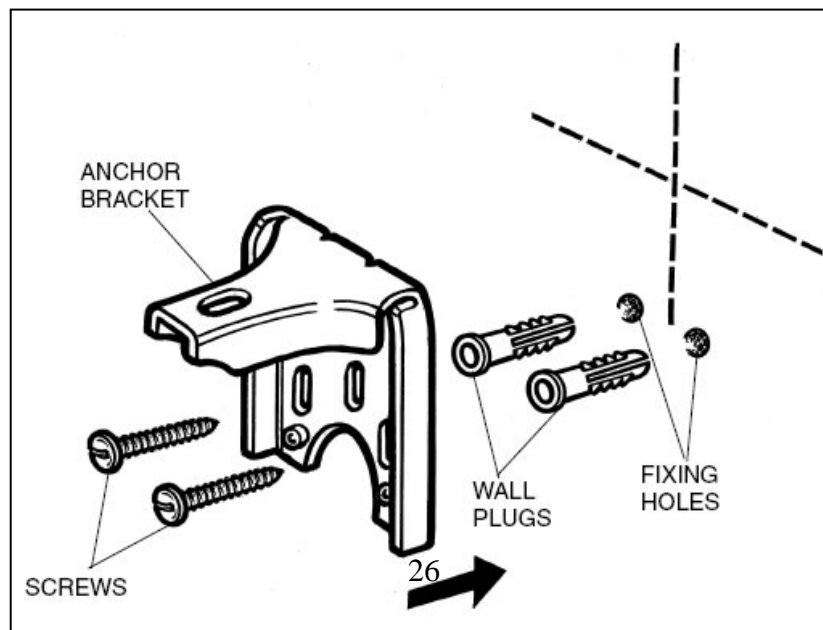

- Decide on a suitable wall location for fitting the anchor brackets directly behind each cooker safety chain.
- Hold the chain anchor up to the wall where it will be required and mark the fixing holes.
- Drill the fixing holes and fix the chain anchors to the wall using the screws provided and suitable wall plugs for the type of wall being fixed to.
- Leave the chains unattached until the installation process has been completed.

Securing the safety chains

- Before securing the safety chains, check that you have completed the installation process and that all connections have been made successfully and that the cooker is in its final operating position.

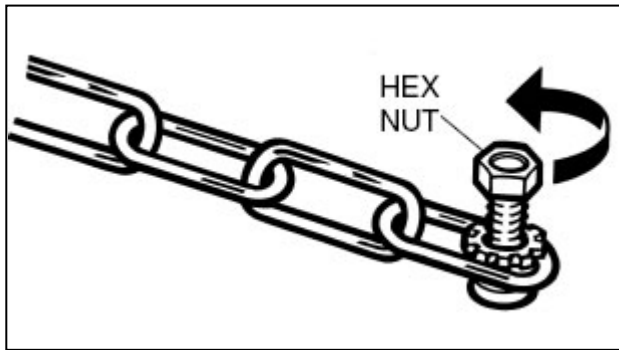

- ***To fix the security chains to their anchor brackets:*** Unscrew the hex nut at the unattached end of the safety chain.

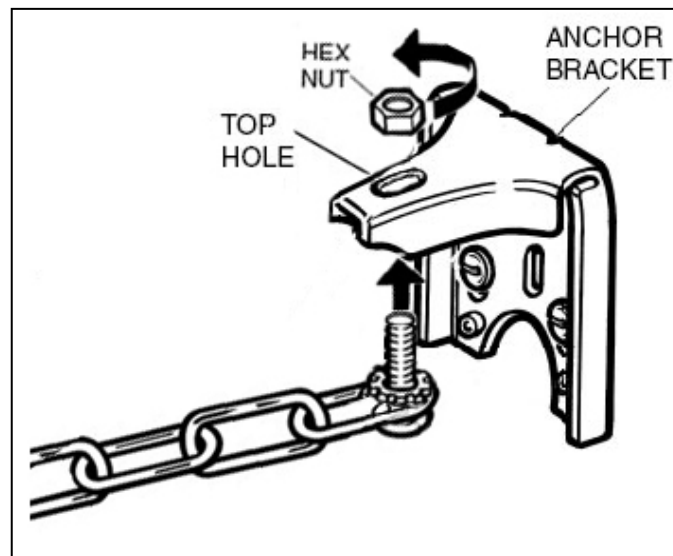

- Insert the screw upwards into the top hole of the anchor bracket.
- When the screw is fully inserted in the bracket, tighten the hex nut to secure the end chain link into position.

Electrical connection



YOUR COOKER IS INTENDED FOR FITTED AND PERMANENT INSTALLATION.

- Before connecting the appliance, make sure that the supply voltage marked on the rating plate corresponds with your mains supply voltage.
- We recommend that the appliance is connected by a qualified electrician, who is a member of the N.I.C.E.I.C. and who will comply with the I.E.E. and local regulations.
- **WARNING: THIS APPLIANCE MUST BE EARTHED.**
- This appliance is supplied with a moulded plug, which must be connected to an earthed socket.
- If in future you need to change the fuse in this plug, then a 3 amp ASTA approved (BS 1362) fuse **must** be used.
- If the earthed socket is not accessible after the appliance is installed. Then the cooker must be wired into a 13A double pole switched fused spur outlet, having 3 mm contact separation and the fuse rating reduced to 3 amps. This should be placed in an easily accessible position adjacent to the appliance. The spur outlet must still be accessible even when your cooker is installed.
- The wiring in the mains lead is coloured as follows:

Brown	Live
Blue	Neutral
Green and yellow	Earth

- As the colours of the wires in the appliance's mains lead may not correspond with the coloured markings identifying the terminals in your spur box, please proceed as follows:

The **brown wire** must be connected to the terminal marked "L" (live), or coloured **red**.

The **blue wire** must be connected to the terminal marked "N" (neutral), or coloured **black**.

The **green and yellow wire** must be connected to the terminal marked "E" (earth), or by the earth symbol, or coloured **green and yellow**.

- When the connection is completed, no stray strands or cut wire should be present. The cord clamp must be secured over the outer sheath.
- Broken or damaged power leads must only be replaced by a suitably qualified person. A power lead of a similar type must be used in replacement.

Gas connection



This appliance must be installed by a competent person in accordance with the current versions of the following UK (United Kingdom) or ROI (Republic of Ireland) Regulations and Safety Standards or their European Norm Replacements.

Important information

- This cooker is supplied to run on ***natural gas only*** and cannot be used on any other type of gas without modification.
- Conversion for use on LPG and other gases must only be undertaken by a qualified person. For information on the use of other gases, please contact the Baumatic Technical Department.
- The cooker must be installed by a qualified person, in accordance with the current edition of the Gas Safety (Installation and Use) (Amendment) Regulations and the relevant building/I.E.E. Regulations.
- Failure to install the appliance correctly could invalidate Baumatic's guarantee and lead to prosecution under the regulations quoted above.
- In the UK, ***GASSAFE*** registered installers are authorised to undertake the installation and service work, in compliance with the above regulations.

Gas Safety (Installation and Use) Regulations

- It is the law that all gas appliances are installed by competent persons in accordance with the current edition of the ***Gas Safety Installation and Use Regulations***.
- It is in your interest and that of safety to ensure compliance with the law.
- In the UK, GASSAFE registered installers work to safe standards of practice. The cooker must also be installed in accordance with the current edition of BS 6172. Failure to install the cooker correctly could invalidate the warranty, liability claims and lead to prosecution.
- ***IMPORTANT: It is a requirement for a stability chain to be fitted to the appliance. Please see pages 26-28 for more detailed information on this.***

Gas connection



ALL INSTALLATION AND SERVICE WORK MUST BE CARRIED OUT BY A GASSAFE REGISTERED ENGINEER.

- Prior to installation, ensure that the gas supply conditions (nature of the gas and gas pressure) and the adjustment conditions are compatible. The adjustment conditions for this appliance are stated on the rating plate which can be found on the back cover.
- This appliance is not designed to be connected to a combustion product evacuation device. Particular attention should be given to the relevant requirements regarding ventilation.



- ***IMPORTANT: FIBRE WASHERS MUST BE IN PLACE WHEN CONNECTING THE GAS HOSE.***
- Connection to the cooker should be made with an approved appliance flexible connection to BS669.

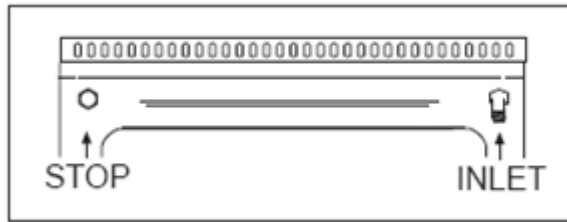

- This cooker can be connected to the supply both on the right and left hand side at the rear of the cooker. To reverse the position, remove the blanking plug and refit it to the opposite side to where the hose is being connected.
- If the cooker has been converted for use with LPG, then it should be connected to the gas supply using an appropriate bayonet type hose. The hose **MUST** be suitable for use with LPG gas, these are identifiable by a red band or stripe.
- A hose length of 0.9m to 1.25m is recommended. The length of hose chosen should be such that when the cooker is in situ, the hose does not touch the floor.
- Care should be taken to ensure that the temperature rise of areas at the rear of the cooker that are likely to come in contact with the flexible hose do not exceed 70°C.
- Gas pressure may be checked on a semi-rapid hob burner. Remove the appropriate injector and attach a test nipple. Light the other burners and observe that the gas pressure complies with the gas standards in force.

Gas adjustment (Conversion to LPG for the hob top)



All work must be carried out by a GASSAFE registered engineer.

IMPORTANT: Always isolate the cooker from the electricity supply before changing the injectors and/or adjusting the minimum flow of the burners.

- Remove the pan supports, burner cap and burner rings.



- Unscrew the injector and replace it with the required injector for the new gas supply according to the table below.

Burner Type	Gas Type	Pressure Mbar	Injector Marking (1/100mm)	Power (Kw)	
				Max	Min
Auxillary (Small)	Natural Gas	20	72	1	0.3
	Liquid Gas	28..30/37	50		
Semi Rapid (Medium)	Natural Gas	20	97	1.75	0.6
	Liquid Gas	28..30/37	65		
Rapid (Large)	Natural Gas	20	115	3	1
	Liquid Gas	28..30/37	85		

- When all four jets have been replaced, reassemble all the burners carefully, taking particular care to make sure that the burners and burner caps are aligned properly.
- After changing the injectors YOU MUST change the minimum flow rate.

Minimum flow adjustment for hob gas taps.



All work must be carried out by a GASSAFE registered engineer.

- Ignite the large (rapid) burner and set the control knob to the minimum position.
- Remove the control knob to access a small adjusting screw.

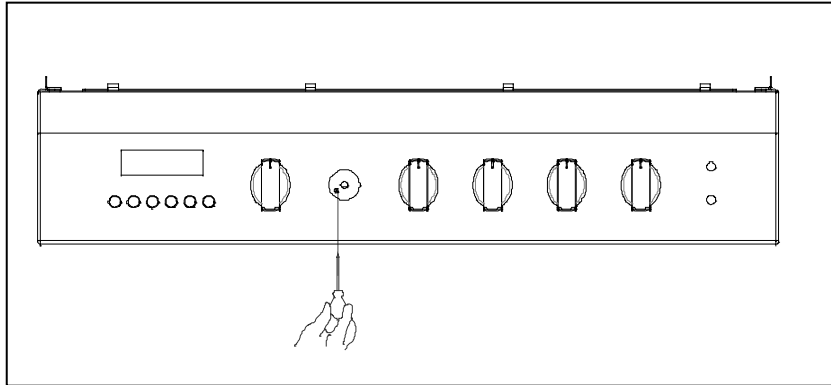

- Using a suitable screwdriver, turn the screw clockwise to decrease the flow of gas and make the flame smaller. Turn the screw anti-clockwise to increase the flow of gas and make the flame bigger.
- To establish the correct adjustment, the flame should be approximately 3 – 4 mm in length. For Butane / Propane gas, the adjusting screw must be tightly screwed in.
- Refit the control knob.
- Turn the control knob to maximum and then back to minimum two or three times to make sure the flame does not go out when the control knob is set to minimum.
- If the flame does go out then remove the control knob and repeat the procedure again.
- Repeat these steps for the semi-rapid and auxiliary burners.

Gas adjustment (Conversion to LPG for the oven and grill)



All work must be carried out by a GASSAFE registered engineer.

IMPORTANT: Always isolate the cooker from the electricity supply before changing the injectors and/or adjusting the minimum flow of the burners.

- o Before you can change the injectors on the grill and oven burners, you must unscrew the burners from their fixing brackets.

Grill burner

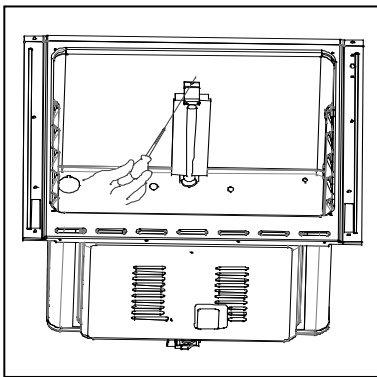

Oven burner

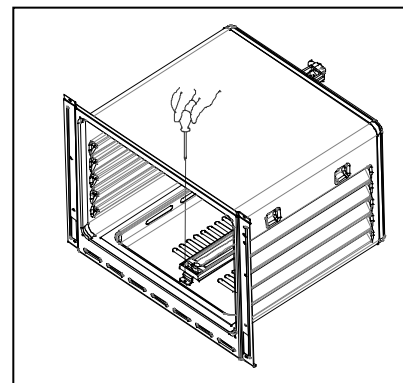

- o The grill burner is located at the top of the cavity and the oven burner is located under the bottom cavity. You should remove the metal plate to access the oven burner.
- o When you have removed the burners you will be able to see the injector.

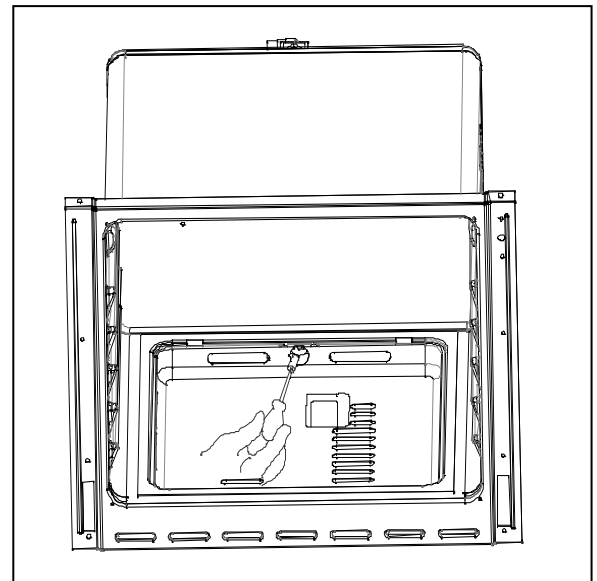
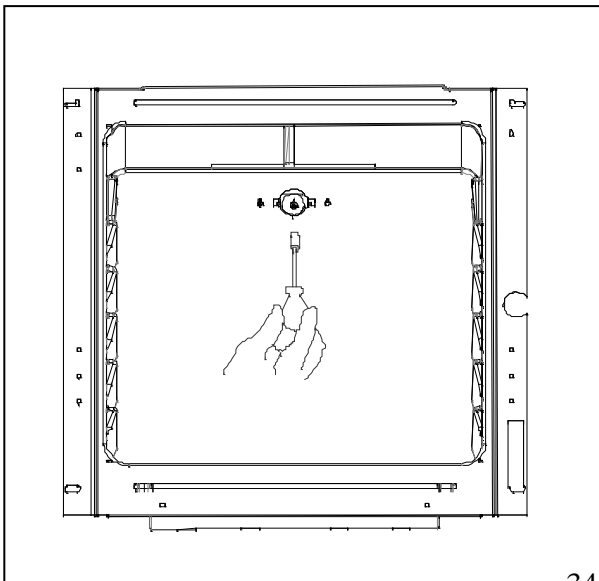

screw the injector and replace it with the required injector for the new gas supply according to the table below.

Burner Type	Gas Type	Pressure Mbar	Injector Marking (1/100mm)	Power (Kw)	
				Max	Min
Oven Burner	Natural Gas	20	1.05	2.1	0.8
	Liquid Gas	28..30/37	0.72		
Grill Burner	Natural Gas	20	1.00	1.8	0.6
	Liquid Gas	28..30/37	0.66		

- After changing the injectors YOU MUST change the minimum flow rate.

Minimum flow adjustment for the oven and grill burners



All work must be carried out by a GASSAFE registered engineer.

- In order to access the adjusting screws to change the minimum flow rate of the grill and oven burners, you need to remove the hob top and control panel.
- To take the hob top off, remove the screws fixing the hob to the cooker.

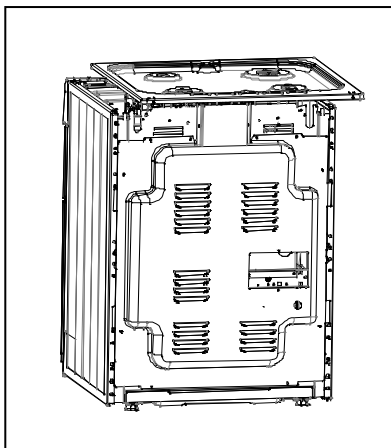
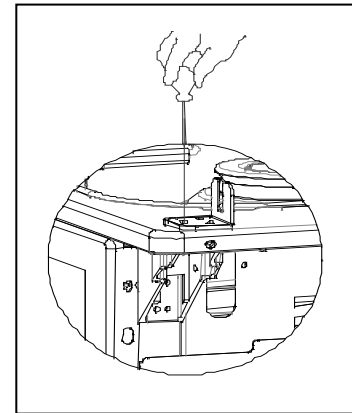
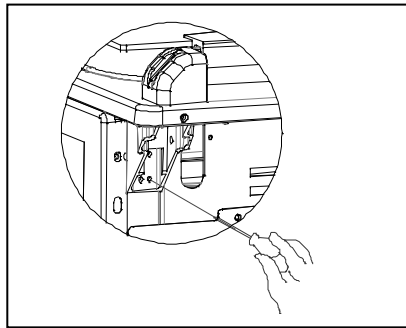
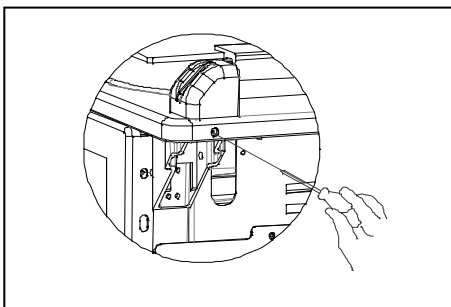

- When all the screws have been removed, slide the hob from the back to the front and lift it off the support brackets which hold the hob down at the front of the cooker.

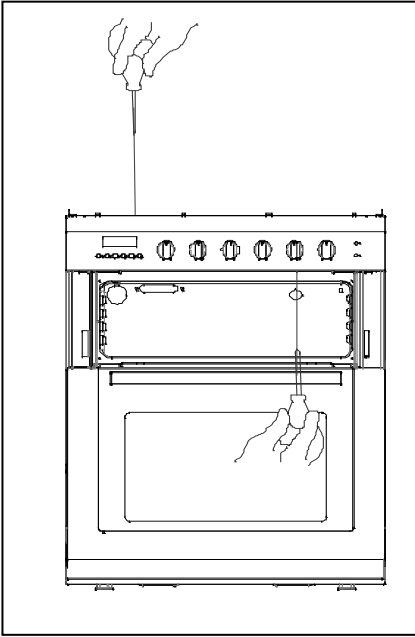

- To take off the control panel, remove the screws fixing the control panel.
- When the screws have been removed, you can take off the control knobs and remove the control panel by pulling it to the front.

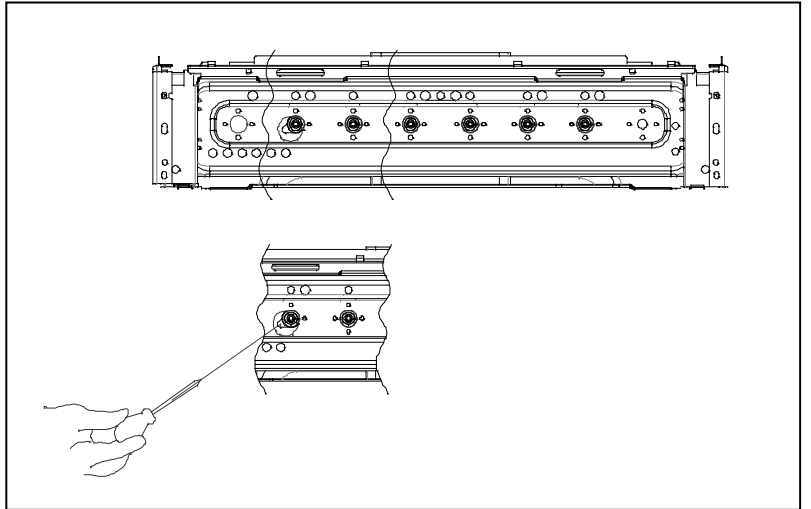
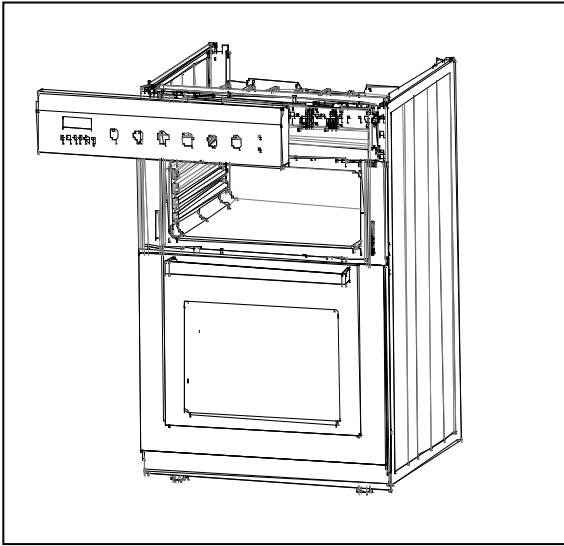

- Locate the adjusting screws for the grill and oven burners. These will be positioned to the left hand side of the grill and oven thermostat taps.
- With the control panel removed, refit the oven and gas thermostat control knobs. Ignite each burner separately and set the control knob to the minimum position.
- Using a suitable screwdriver, turn the screw clockwise to decrease the flow of gas and make the flame smaller. Turn the screw anti-clockwise to increase the flow of gas and make the flamer bigger.

- To establish the correct adjustment, the flame should be approximately 3 - 4 mm in length. For Butane / Propane gas, the adjusting screw must be tightly screwed in.
- Turn the control knob to maximum and then back to minimum two or three times to make sure that the flame does not go out when the control knob is set to minimum.
- If the flame does go out, repeat the procedure again.
- Remove the control knobs for the oven and grill and refit the control panel and hob top taking care to ensure they are fitted correctly.
- Replace all the control knobs.
- Your cooker should now be adjusted correctly to work on LPG gas.

My appliance isn't working correctly

The gas oven burner or grill burner do not light.

- * Check that the oven is switched on at your mains supply.
- * Check that the fuse in the spur outlet doesn't need replacing.
- * Check that there is not a problem with your gas supply

Food is cooking too quickly or too slowly.

- * Check that you are cooking at an appropriate temperature and shelf level.

The oven is not cooking evenly.

- * Check that the oven is installed correctly.
- * Check that you are cooking at an appropriate temperature and shelf level.

The oven light is not working.

- * Refer to the "Replacing the oven bulb" section.

I am getting condensation in my oven.

- * Steam and condensation is a natural by product of cooking any food with high water content, such as frozen food, chicken etc.
- * You may get condensation in the oven cavity and forming between the oven door glasses. This is not necessarily a sign that the oven is not working correctly.
- * Do not leave food in the oven to cool after it has been cooked and the oven has been switched off.
- * Use a covered container, where practical, when cooking to reduce the amount of condensation that forms.



IMPORTANT: If your appliance appears not to be operating correctly, then you should disconnect it from your mains supply and then contact Baumatic Customer Care on telephone number (0118) 933 6911.

DO NOT ATTEMPT TO REPAIR THE APPLIANCE YOURSELF.

Please note that if an engineer is asked to attend whilst the product is under guarantee and finds that the problem is not the result of an appliance fault, then you may be liable for the cost of the call out charge.

The appliance must be accessible for the engineer to perform any necessary repair. If your appliance is installed in such a way that an engineer is concerned that damage will be caused to the appliance or your kitchen, then he will not complete a repair.

This includes situations where appliances have been tiled in, sealed in with sealant, have wooden obstructions placed in front of the appliance, like plinths. Or any installation other than the one specified by Baumatic Ltd. has been completed.

Please refer to the conditions of guarantee that appear on the warranty card that you receive with the appliance.

Baumatic Consumables

- **BC001** Degreaser for Dishwashers (200 g)
- **BC002** Descaler for Washing Machines and Dishwashers (200 g)
- **BC003** Ceramic Hob Cleaner (250 ml)
- **BC004** Oven Cleaner (250 ml)
- **BC005** Stainless Steel Cleaner and Protector (250 ml)
- **BC007** E-Cloth – General Purpose Cloth
- **BC008** – Microwave Cover

To order a Baumatic consumables product please call 0123 5437 244 and quote the product code. You can also order online from eshop.baumatic.co.uk



United Kingdom

Baumatic Ltd.,
Baumatic Buildings,
6 Bennet Road,
Reading, Berkshire
RG2 0QX
United Kingdom

Sales Telephone

(0118) 933 6900

Sales Fax

(0118) 931 0035

Customer Care Telephone

(0118) 933 6911

Customer Care Fax

(0118) 986 9124

Spares Telephone

(01235) 437244

Advice Line Telephone

(0118) 933 6933

E-mail:

sales@baumatic.co.uk
customercare@baumatic.co.uk
spares@baumatic.co.uk
technical@baumatic.co.uk

Website:

www.baumatic.co.uk

Facebook:

www.facebook.com/baumatic.uk

Republic of Ireland

Service Telephone

1-890 812 724

Spares Telephone

091 756 771

Czech Republic/Slovakia

Baumatic s.r.o.

Lípová 665/1
460 01 Liberec 4
Czech Republic

Panenská 34
811 03 Bratislava - Staré Mesto
Slovakia

+420 483 577 200 (CZ)
+421 255 640 618 (SK)

www.baumatic.cz
www.baumatic.sk

Germany

Kundendienst & Ersatzteile

Deutschland 0049(0)180-5888975
Oesterreich +43 (0) 820 / 420423

www.baumatic.de

Italy

Baumatic Italia S.R.L.
Via Galvani N.3
35011 Campodarsego (PD)

+3904 9920 2297
www.baumatic.it

Holland

Baumatic Benelux B.V.
Dukdalfweg 15d
1332 BH ALMERE
Nederland

+31(0)36 549 1553
www.baumatic.nl

