

**BSO616SS**

60 cm Fan Oven

**BSO636-SS/WGL**

60 cm Multifunction Oven

# INSTRUCTION MANUAL



**Baumatic®**

# User Manual for your Baumatic

## **BSO616SS** 60 cm Fan Oven

## **BSO636-SS/WGL** 60cm Multifunction Oven



***NOTE:*** This User Instruction Manual contains important information, including safety & installation points, which will enable you to get the most out of your appliance. Please keep it in a safe place so that it is easily available for future reference; for you or any person not familiar with the operation of the appliance.

# Contents

<b>Environmental note</b>	4
<b>Important safety information</b>	5 - 7
<b>Specifications</b>	8 - 10
Product and aperture dimensions	8
Product specifications	8
Standard accessories	8
Electrical details	9
Cooling fan	9
Control panel	10
Oven programmer/timer display	10
<b>Setting and using the oven programmer/timer</b>	11-15
Selecting manual operation mode	11
Setting the time of day	11
Before first use	11
Setting the minute minder function	12
Setting the semi-automatic cooking function	13
Setting the end cook function	14
Setting the automatic cooking function	15
Cancelling a timer function	16
Adjusting the volume of the audio signal	16
Changing the time of day	16
<b>Selecting a cooking function and temperature</b>	17-21
Selecting an oven function	17
Oven functions	17-19
Thermostat control knob	19
Oven operating light	19
Cooking guidelines	19-20
Warnings	20
Shelf positions	21
<b>Cleaning and maintenance</b>	21-24
Replacing the oven bulb	22
Removing the oven door for cleaning	23
Removing the inner door glass for cleaning	24
<b>Installation</b>	25-27
Electrical connection	25
Installing the oven into the kitchen cabinet	26
Positioning the appliance	26
Ventilation requirements	27
<b>My appliance isn't working correctly</b>	28-30
<b>Cooking Tables</b>	30-33
<b>Baumatic consumables</b>	33
<b>Contact details</b>	34

**This appliance is marked according to the European directive 2002/96/EC on Waste electrical and Electronic Equipment (WEEE). By ensuring this product is disposed of correctly, you will help prevent potential negative consequences for the environment and human health, which could otherwise be caused by inappropriate waste handling of this product.**

The symbol  on the product, or on the documents accompanying the product, indicates that this appliance may not be treated as household waste. Instead it shall be handed over to the applicable collection point for the recycling of electrical and electronic equipment.

**Disposal must be carried out in accordance with local environmental regulations for waste disposal.**

**For more detailed information about treatment, recovery and recycling of this product, please contact your local city office, your household waste disposal service or the shop where you purchased the product.**



- The packaging materials that Baumatic uses are environmentally friendly and can be recycled.
- Please discard all packaging material with due regard for the environment.

## IMPORTANT SAFETY INFORMATION



Your safety is of the utmost importance to Baumatic. Please make sure that you read this instruction booklet **before** attempting to install or use the appliance. If you are unsure of any of the information contained in this booklet, please contact the Baumatic Customer Care Department.

### General Information

- This appliance is designed for domestic household use and can be built into a standard kitchen cabinet or housing unit.
- **IMPORTANT:** *The adjacent furniture or housing and all materials used in the installation **must** be able to withstand a minimum temperature of 85°C above the ambient temperature of the room it is located in, whilst in use.*
- Certain types of vinyl or laminate kitchen furniture are particularly prone to heat damage or discolouration at temperatures below the guidelines given above.
- Any damage caused by the appliance being installed in contravention of this temperature limit, or by placing adjacent cabinet materials closer than 4mm to the appliance, **will be the liability of the owner.**
- The use of this appliance for any other purpose or in any other environment without the express agreement of Baumatic Ltd will invalidate any warranty or liability claim.
- Your new appliance is guaranteed against electrical or mechanical defects, subject to certain exclusions that are noted in Baumatic's Conditions Of Guarantee. The foregoing does not affect your statutory rights.
- ***Repairs may only be carried out by Baumatic service engineers or their authorised service agents.***

### Warning and safety instructions

- This appliance complies with all current European safety legislation. Baumatic does wish to emphasise that this compliance does not remove the fact that the appliance surfaces **will become hot during use and retain heat after operation.**

- This appliance is not intended for use by persons (including children) with reduced physical, sensory or mental capabilities, or lack of experience and knowledge, unless they have been given supervision or instruction concerning use of the appliance by a person responsible for their safety.

### **Child Safety**

- Baumatic strongly recommend that babies and young children are prevented from being near to the appliance and not allowed to touch the appliance **at any time**.
- If it is necessary for younger family members to be in the kitchen, please ensure that they are kept under close supervision at all times.
- Children should be supervised to ensure that they do not play with the appliance.

### **General Safety**

- **Do not** place heavy objects on the oven door or lean on the oven door when it is open, as this can cause damage to the oven door hinges.
- **Do not** leave heated oil or fat unattended, as this is a fire risk.
- **Do not** place pans or baking trays directly on the base of the oven cavity, or line it with aluminium foil.
- **Do not** allow electrical fittings or cables to come into contact with areas on the appliance that get hot.
- **Do not** use the appliance to heat the room it is located in or to dry clothing.
- **Do not** install the appliance next to curtains or soft furnishings.
- **Do not** attempt to lift or move cooking appliances by using the oven door or handle, as this may cause damage to the appliance or result in injury to the person lifting the appliance.

## Cleaning

- Cleaning of the oven should be carried out on a regular basis.
- Great care should be taken whilst using this appliance and when following the cleaning procedure.
- **IMPORTANT:** *The appliance must be disconnected from the mains before following the cleaning procedure.*

## Installation



***This appliance must be correctly installed by a suitably qualified person, strictly in accordance with the manufacturer's instructions.***

- ***Baumatic Ltd declines any responsibility for injury or damage, to person or property, as a result of improper use or installation of this appliance.***
- Heat, steam and moisture will be created during use of the appliance, take care to avoid injury and ensure that the room is adequately ventilated. If the appliance is going to be used for prolonged periods of time, then additional ventilation may be required.
- Please consult with your qualified installer if you are in any doubt about the amount of ventilation that you will require.

## Declaration of conformity

This appliance complies with the following European Directives:

- 2006/95/EC regarding "low voltage"
- 2004/108/EC regarding "electromagnetic disturbances"
- Regulation (EC) N° 1935/2004 regarding "materials in contact with food"
- The above directives comply with 93/68/EEC regarding CE marking.
- The manufacturer declares that the oven is built using certified materials and requires the appliance to be installed in accordance with the standards currently in force. This appliance must be used by a trained person for domestic purposes only.

## Specifications

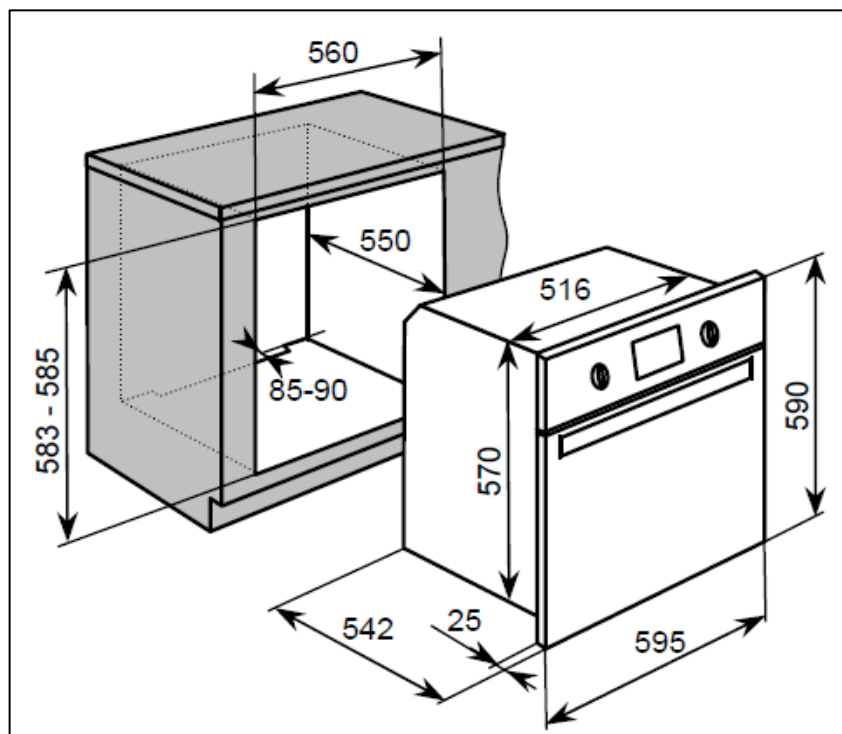

### Product Dimensions

Height: 590 mm  
Width: 595 mm  
Depth: 542 mm

### Aperture Dimensions

583 mm – 585 mm  
560 mm  
550 mm (min)

### Product specifications

- 4 oven functions (BSO616SS)
- 7 oven functions (BSO636-SS/WGL)
- Energy efficiency class: A
- Oven gross capacity: 59 litres
- Oven net capacity: 50 litres
- LED full programmer
- Cooling fan
- Double-glazed removable door
- Removable inner door glass
- Oven light

### Standard accessories

- 2 x Safety shelves
- Enamelled baking tray
- Trivet

### Optional extra

- BPS2 Pizza stone



## Electrical details

<b>Rated Voltage:</b>	220-240 Vac 50 Hz
<b>Supply Connection:</b>	13A (double pole switched fused outlet with 3mm contact gap)
<b>Max Rated Inputs:</b>	2.35 kW <b>(BSO616SS)</b>
<b>Max Rated Inputs:</b>	2.40 kW <b>(BSO636-SS/WGL)</b>
<b>Mains Supply Lead:</b>	3 x 1.5mm <sup>2</sup>
<b>Oven Light Bulb:</b>	25 W/300°C screw type pygmy

## Cooling fan

- A tangential cooling fan is fitted inside of this appliance, to make the internal temperature of the oven stable and the external surface temperature lower.
- After you have finished cooking and switched off the oven, the cooling fan will continue to run for a period of time afterwards. The length of time will depend on how long the oven has been switched on for and at how high a temperature.

For future reference please record the following information which can be found on the rating plate and the date of purchase which can be found on your sales invoice. The rating plate for your oven can be located by opening the oven door and looking around the outer edge of the oven chassis.

**Model Number** .....

**Serial Number** .....

**Date of Purchase** .....

## Control Panel

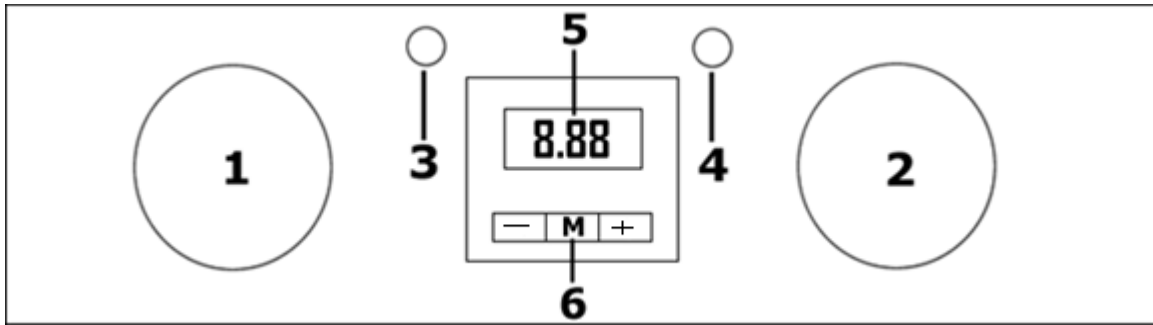

- 1) Oven function selector knob
- 2) Thermostat control knob
- 3) Power indicator light
- 4) Oven operating light
- 5) LED display
- 6) Oven programmer/timer

### Oven programmer/timer

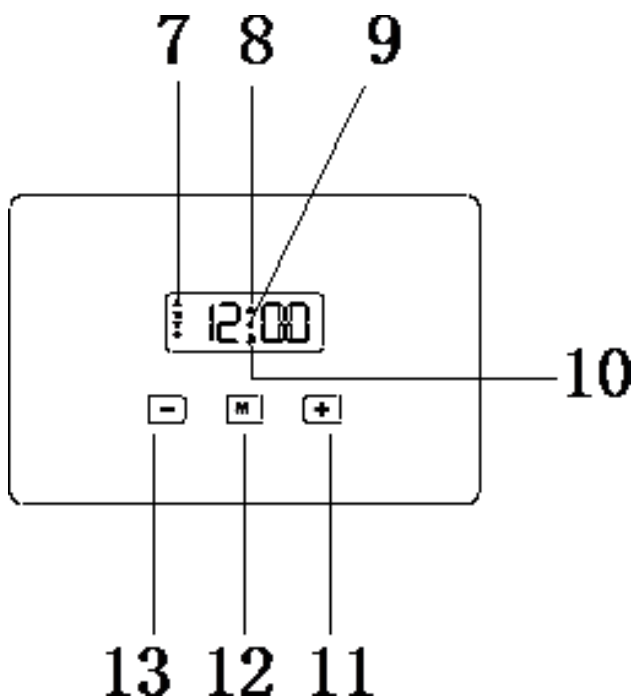

- 7) Automatic cooking symbol
- 8) Oven in use symbol
- 9) Decimal point symbol
- 10) Minute minder symbol
- 11) Plus button
- 12) Programme button
- 13) Minus button

## Initial set-up of your oven

### Selecting manual operation mode

After your appliance is connected to your mains supply for the first time (or after a power-cut) the numbers on the timer display will flash. Before you can select a cooking function or set a temperature, you must set the appliance into “manual operation” mode.

- To select manual operation mode, press the program button **(12)** for three seconds. The oven in use symbol **(8)** will light in the display.

### Setting the time of day

*After your appliance is connected to your mains supply for the first time, you must set the time of day before you can use the oven.*

- Make sure the oven is in manual operation mode (as outlined above).
- Press the program button **(12)** once to set the time of day. Whilst the decimal point symbol **(9)** is flashing, use the plus **(11)** and minus **(13)** buttons to set the correct time of day.
- When the correct time of day is shown on the LED display, release the plus and minus buttons and wait a few seconds. The decimal point symbol **(9)** will stop flashing and the oven is ready to use.

### Before first use

- To remove any residue from the oven that may have been left from the manufacturing process, you should select the fan oven function and set the thermostat to its maximum temperature setting.
- It is perfectly normal for a smell to be produced during this process.
- You should make sure that any windows in the room are left open during this process.
- It is advisable for you not to remain in the room whilst the burning off process is taking place.
- You should leave the oven on maximum setting for 30 – 40 minutes.
- After the oven cavity has cooled, it should then be cleaned with warm soapy water, using either a sponge or soft cloth. No abrasive cleaners should be used.

- Outer parts of the oven should be cleaned with warm soapy water, using either a sponge or soft cloth. No abrasive cleaners should be used.
- We would recommend that an appropriate stainless steel cleaner and polish is regularly used on the stainless steel surfaces of this appliance.

## Timer functions

### The minute minder function

*The minute minder function is a countdown time that can be set on the oven programmer/timer. When the countdown time has finished, an audible signal will sound.*

- Press the programme button **(12)** twice. The decimal point **(9)** starts to flash and the minute minder symbol **(10)** will light on the display and will show "00:00".
- Use the plus **(11)** and minus **(13)** buttons to set the countdown time that you require.
- The maximum countdown time that can be set is 23 hours and 59 minutes.
- When the correct countdown time appears on the LED display, release the plus and minus buttons and the countdown will start immediately.
- The minute minder symbol **(10)** will remain in the LED display to show that a countdown time is in progress.
- After a few seconds the LED display will return to showing the time of day.
- At the end of the countdown time, an audible signal will sound and the oven in use symbol will go out. The audible signal will sound for 7 minutes before switching off or you can silence it by pressing any of the oven timer buttons.

***IMPORTANT: If the oven is in use whilst using the minute minder function, the oven WILL NOT switch off at the end of the countdown time. YOU MUST turn the oven function selector knob and the thermostat control knob to their OFF positions.***

## The semi-automatic cooking function

*This function will allow you to set a countdown time similar to the minute minder function, however the oven will switch off at the end of the cooking time.*

- Place the food that you want to cook inside of the oven and close the door.
- Select an oven function and cooking temperature using the relevant control knobs.
- Press the programme button **(12)** three times. The decimal point, the oven in use symbol **(8)** and the Automatic cooking symbol **(7)** will flash on the LED display. The display will show "00:00".
- Use the plus **(11)** and minus **(13)** buttons to set the cooking time that you require.
- The maximum countdown time that can be set is 10 hours.
- When the correct countdown time appears on the LED display, release the plus and minus buttons. Cooking will begin immediately, after a few seconds the countdown time will start.
- At the end of the cooking time the oven will turn off and an audible signal will sound. The automatic cooking symbol **(7)** and the minute minder symbol **(10)** will flash on the LED display.
- To reset the oven and cancel the audible alarm, press any button once to stop the alarm. Then press and hold the programme button twice for 3 seconds. After the first press the oven time will flash, and on the second press the oven in use symbol appears on the LED display and the automatic cooking **(7)** symbol goes out.
- **IMPORTANT:** *If you have not turned the oven function selector knob and thermostat control knob to their OFF positions, when you reset the oven it will continue to heat.*

## The end of cooking function

*This function is similar to the semi-automatic function, however instead of setting a countdown time, you select the time of day that you want the oven to switch off at.*

- Place the food that you want to cook inside of the oven and close the door.
- Select an oven function and cooking temperature using the relevant control knobs.
- Press the programme button **(12)** four times. The decimal point starts to flash, and the oven in use symbol **(8)** and the Automatic cooking symbol **(7)** will light on the LED display.
- The display will show the current time of day which will flash. Use the plus **(11)** and minus **(13)** buttons to set the cooking end time that you require.
- The maximum end time that can be set is 10 hours into the future.
- When the correct end time appears on the LED display, release the plus and minus buttons. Cooking will begin immediately, after a few seconds the countdown time will start.
- At the end of the cooking time the oven will turn off and an audible signal will sound. The automatic cooking symbol **(7)** and the Minute Minder symbol **(10)** will flash on the LED display.
- To reset the oven and cancel the audible alarm, press any button once to stop the alarm. Then press and hold the programme button twice for 3 seconds. After the first press the oven time will flash, and on the second press the oven in use symbol appears on the LED display and the automatic cooking **(7)** symbol goes out.
- **IMPORTANT:** *If you have not turned the oven function selector knob and thermostat control knob to their OFF positions, when you reset the oven it will continue to heat.*

## The automatic cooking function

*This function will allow you to set the time of day that you want the oven to switch off at and how long you want the oven to cook for.*

- Place the food that you want to cook inside of the oven and close the door.
- Select an oven function and cooking temperature using the relevant control knobs.
- Press the programme button **(12)** three times. The decimal point starts to flash, and the oven in use symbol **(8)** and the automatic cooking symbol **(7)** will light on the LED display.
- Use the plus **(11)** and minus **(13)** buttons to set the cooking time that you require.
- The maximum cooking duration time that can be set is 10 hours.
- **IMMEDIATELY** press the programme button.
- The display will then show the current time of day which will flash. Use the plus **(11)** and minus **(13)** buttons to set the cooking **end time** that you require.
- The maximum end time that can be set is 10 hours into the future.
- When the correct end time appears on the LED display, release the plus and minus buttons.
- Cooking will begin at the calculated preset time.
- At the end of the cooking time the oven will turn off and an audible signal will sound. The automatic cooking symbol **(7)** and the Minute Minder symbol **(10)** will flash on the LED display.
- To reset the oven and cancel the audible alarm, press any button once to stop the alarm. Then press and hold the programme button twice for 3 seconds. After the first press the oven time will flash, and on the second press the oven in use symbol appears on the LED display and the automatic cooking **(7)** symbol goes out.
- **IMPORTANT:** *If you have not turned the oven function selector knob and thermostat control knob to their OFF positions, when you reset the oven it will continue to heat.*

## Cancelling a timer function

- To cancel the minute minder function press the programme button **(12)** once to select the minute minder function and then reduce the time to "00:00" .
- To cancel the semi-automatic timer press the programme button **(12)** three times to select the semi-automatic timer then and reduce the time to "00:00".
- To cancel the end of cooking timer press the programme button **(12)** four times to select the end of cooking timer and then reduce the time to the current time of day.
- To cancel the automatic timer press the programme button **(12)** three times and reduce the (duration) time to "00:00" and then press the program button again and reduce the (end) time to the current time of day.
- **IMPORTANT:** *If you do not turn the oven function selector knob and thermostat control knob to their OFF positions, when you reset the timer function, it will continue to heat.*

## Adjusting the audible signal

*The audible signal has 3 tones. To adjust the signal you should proceed as follows: -*

- **IMPORTANT:** *The oven timer must not be in any form of countdown mode and the oven in use symbol **(8)** must be lit.*
- Press and hold down the minus **(13)** and plus **(11)** buttons simultaneously for 2 seconds and you will hear an audible signal. This is the audible signal which is currently set.
- Press and hold down the minus **(13)** and plus **(11)** buttons simultaneously again for 2 seconds to hear the next audible signal which will be set. This process can be repeated.
- When you hear the audible signal that you wish to use, release all buttons and wait for the display to go back to showing the time of day. The audible signal has now been set.

## Changing the time of day

- **IMPORTANT:** *The oven timer/programmer must not be in any form of countdown mode and the oven in use symbol **(8)** must be lit.*
- Please follow the guidelines on "setting the time of day".



## Selecting a cooking function and temperature



**IMPORTANT:** Make sure that you have set your oven into manual operation mode before selecting an oven function and temperature.

### Selecting an oven function

The oven function selector knob should be used to select the particular mode of cooking that you require. The appliance will utilise different elements within the oven cavity, depending on the oven function that you select. When a function is selected, the power indicator light will come on.

#### BSO616SS Oven functions:



**OVEN LIGHT:** Separate light control which allows the light to be switched on, even when the oven is not cooking.



**DEFROST MODE:** The fan runs without heat to reduce the defrosting time of frozen foods. The time required to defrost the food will depend on the room temperature, the quantity and type of food. Always check food packaging for the defrosting instructions.



**FAN OVEN:** This method of cooking uses the circular element while the heat is distributed by the fan. This results in a faster and more economical cooking process. The fan oven allows food to be cooked simultaneously on different shelves, preventing the transmission of smells and tastes from one dish onto another.



**HALF GRILL:** This method of cooking utilises the inner part only of the top element, which directs heat downwards onto the food. This function is suitable for grilling small portions of bacon, toast and meat etc.

## BSO636-SS/WGL Oven functions:



**CONVENTIONAL OVEN:** This method of cooking provides traditional cooking, with heat from the top and lower elements. This function is suitable for roasting and baking on one shelf only.



**FAN OVEN:** This method of cooking uses the circular element while the heat is distributed by the fan. This results in a faster and more economical cooking process. The fan oven allows food to be cooked simultaneously on different shelves, preventing the transmission of smells and tastes from one dish onto another.



**GRILL MODE:** This method of cooking utilises the inner sections of the top element, which directs heat downwards onto the food. This function is suitable for grilling portions of bacon, toast and meat etc.



**FULL GRILL:** This method of cooking utilises the inner and outer parts of the top element, which directs heat downwards onto the food. This function is suitable for grilling medium or large portions of sausages, bacon, steaks, fish etc.



**DEFROST MODE:** The fan runs without heat to reduce the defrosting time of frozen foods. The time required to defrost the food will depend on the room temperature, the quantity and type of food. Always check food packaging for the defrosting instructions.



**FAN AND FULL GRILL:** This method of cooking utilises the top element in conjunction with the fan, which helps to provide a quick circulation of heat. This function is suitable where quick browning is required and "sealing" the juices in, such as steaks, hamburgers, some vegetables etc.



**FAN AND LOWER ELEMENT:** This method of cooking utilises the bottom element in conjunction with the fan, which helps to circulate the heat. This function is suitable for sterilizing and preserving jars.

## Thermostat control knob



- The oven thermostat control knob sets the required temperature of the oven. It is possible to regulate the temperature within a range of 50 - 250°C.
- ***Turn the control knob clockwise.***

## Oven operating light

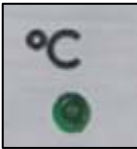

- This light will come on to indicate that the oven's heating elements are in operation. The light will turn off when the temperature set on the thermostat control knob has been reached. It will cycle on and off throughout the cooking time.



***You should not place food inside the cavity, until the correct cooking temperature has been reached.***

## Cooking guidelines

- Please refer to the information given on food packaging for guidance on cooking temperatures and times. Once familiar with the performance of your appliance, temperatures and times can be varied to suit personal preference.
- If you are using the fan oven function, then you should follow the information given on the food packaging for this particular mode of cooking.
- You should pre-heat the oven and not place food inside of it until the oven operating light has gone off. You can choose not to pre-heat when using the fan oven mode; however you should extend the cooking time given on the food packaging by at least ten minutes.
- ***IMPORTANT:*** *You should ALWAYS pre-heat the oven if you are baking.*
- If there is no guidance given on the food packaging specifically for cooking in fan oven mode, you can generally reduce the cooking time and temperature by 10% from the information given for conventional oven cooking.

- Make sure that frozen foods are thoroughly thawed before cooking, unless the instructions on the food packaging advise that you can “cook from frozen”.
- Before cooking, check that any accessories that are not required are removed from the oven.
- Place cooking trays in the centre of the oven and leave gaps between the trays to allow air to circulate.
- Try to open the door as little as possible to view the dishes.
- The oven light will remain on during cooking.

## Warnings

- Keep the oven door closed when using ALL oven functions, including the grill function.
- Do not use aluminium foil to cover the enamelled baking tray or heat items wrapped in aluminium foil under the grill. The high reflectivity of the foil could potentially damage the grill element.
- You should also never line the base of your oven with aluminium foil.
- During cooking, never place pans or cookware directly onto the bottom of your oven. They should always be placed on the shelf provided.
- The internal components of the oven become extremely hot during operation, care should be taken avoid touching them inadvertently.
- **Important:** Be careful when opening the door, to avoid contact with hot parts of the oven and steam.
- When removing any item from the oven, you should **ALWAYS** use an oven glove.
- The grill heating element becomes extremely hot during operation, avoid touching it inadvertently when handling the food which you are grilling.
- **Important:** *Be careful when opening the door, to avoid contact with hot parts and steam.*

## Shelf positions

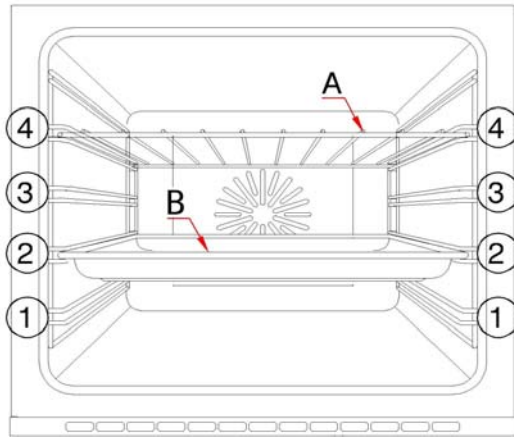

Your oven will come supplied with the following oven furniture:

- (A) Oven shelf**
- (B) Enamelled baking tray**

- The numbers 1 – 4, indicate the different shelf positions that you can utilise within the oven.

*(Image for reference only – actual product may differ slightly)*

- Insert the oven shelf and baking tray between the 2 side rails at any position (1 to 4) on both sides. The oven shelf has safety stops to prevent accidental withdraw. After engaging the oven shelf into the side rails, as you push the oven shelf into the oven, lift the front of the shelf slightly to bypass the stops and allow the oven shelf to slide fully into the rails.
- To remove the oven shelf, gently pull the oven shelf outwards. When the shelf stops, lift the front slightly to bypass the safety stops and then completely withdraw the oven shelf from the oven.
- When installed correctly, the shelf and tray should be horizontal and not on an angle.

## Cleaning and maintenance



***Cleaning operations must only be carried out when the oven is cool.***

***The appliance should be disconnected from your mains supply before commencing any cleaning process.***

- The oven should be thoroughly cleaned before it is operated for the first time and after each use. This will avoid residual food stuffs becoming baked on the oven cavity. After residues have been baked on several times, they are far more difficult to remove.
- **Never** clean the oven surfaces by steam cleaning.
- The oven cavity should only be cleaned with warm soapy water, using either a sponge or soft cloth. No abrasive cleaners should be used.

- Any stains that may appear on the bottom of the oven will have originated from food splashes or spilt food, these splashes occur during the cooking process. These could possibly be a result of the food being cooked at an excessively high temperature or being placed in cookware that is too small.
- You should make sure that the cooking temperature that is selected is appropriate for the food that you are cooking. You should also ensure that the food is placed in an adequately sized dish and use the enamelled baking tray where appropriate.
- Outer parts of the oven should only be cleaned with warm soapy water, using either a sponge or soft cloth. No abrasive cleaners should be used.
- We would recommend that an appropriate stainless steel cleaner and polish is regularly used on the stainless steel surfaces of this appliance.
- Do not use harsh or abrasive cleaners or sharp metal scrapers to clean the oven door glass since they can scratch the surface which may result in shattering.
- If you use any form of oven cleaner on your appliance, then you must check with the manufacturer of the cleaner that it is suitable for use on your appliance.
- ***Any damage that is caused to the appliance by a cleaning product will not be fixed by the manufacturer free of charge, even if the appliance is within the guarantee period.***

### Replacing the oven bulb



***IMPORTANT: The oven must be disconnected from your mains supply before you attempt to either remove or replace the oven bulb.***

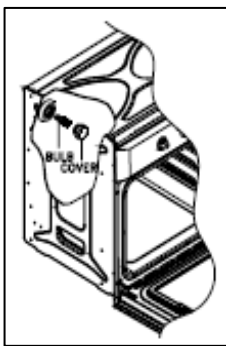

- Remove the oven shelf and the drip tray.
- Remove the light cover by turning it anti-clockwise.
- Unscrew the bulb anti-clockwise and remove it from its holder.
- Replace the bulb with a 25 W/300°C, screw type pygmy.  
***Do not*** use any other type of bulb.
- Place the lamp cover back into position.

## Removing the oven door for cleaning

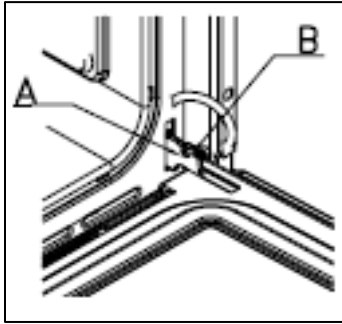

To facilitate the cleaning of the inside of the oven and the outer frame of the oven, the door can be removed as follows: -

- The hinges **(A)** have two movable bolts on them **(B)**.
- If you raise both of the movable bolts **(B)**, then the hinges **(A)** are released from the oven housing.
- You should grip the sides of the door at the centre and then incline it slightly towards the oven cavity and then pull the door gently away from the oven cavity.
- **IMPORTANT:** You should make sure that the door is supported at all times and that you place the door on some padded material whilst cleaning it.
- The oven door and door glass should only be cleaned using a damp cloth and a small amount of detergent. The cloth **MUST NOT** have come into contact with any form of cleaning product or chemical previously.
- To refit the door you should slide the hinges back into their slots and open the door fully.
- **IMPORTANT:** The movable bolts **(B)** must be closed back into their original positions before closing the door.



- **Take care not to dislodge the hinge locking system when removing the door, as the hinge mechanism has a strong spring.**
- **Do not immerse the door in water at any time.**

## Removing the inner door glass for cleaning

- Do not use any abrasive cleaner that could cause damage.
- Remember that if the surface of the glass panel becomes scratched, this could lead to a dangerous failure.
- To facilitate cleaning, the inner door glass can be lifted out.

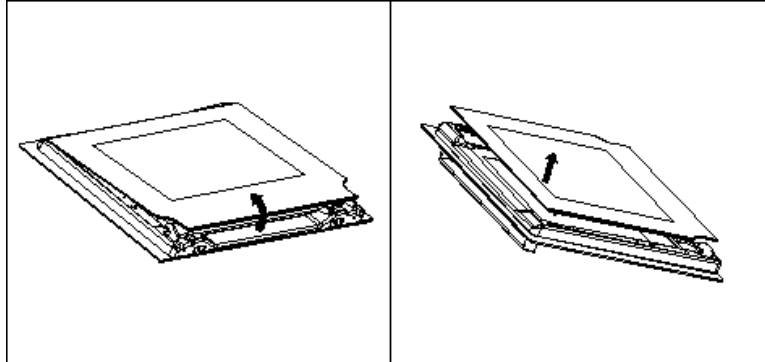

- Grip the top and the bottom of the inner door glass panel.
- Gently pull the **bottom** of the inner door glass panel upwards.

***Do not raise the panel more than 35° as it can damage the securing clips.***

- The securing clips at the top and bottom of the glass panel will pop out and the glass panel will be free to remove.

**If the top securing clips do not pop out when pulling the bottom of the glass panel upwards, then pull the top of the glass panel upwards until the top also pops out.**

- After cleaning, insert the glass panel correctly back into the door in the reverse order. Ensure the securing clips slot back into place and the glass panel locks into place securely.

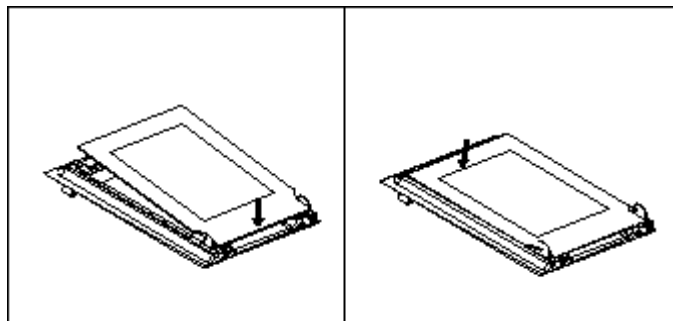

***IMPORTANT: Remember where the panel of glass is removed from so you can reassemble the door correctly. Do not mix the glasses up or rearrange the order.***



## INSTALLATION



*The installation must be carried out by a suitably qualified person, in accordance with the current version of the following.*

- **UK Regulations and Safety Standards** or their European Norm Replacements.
- **Building Regulations** (issued by the Department of the Environment).
- **Building Standards** (issued by the Scottish Development Department).
- **IEE Wiring Regulations.**
- **Electricity At Work Regulations.**

### Electrical connection

Before connecting the appliance, make sure that the supply voltage marked on the rating plate corresponds with your mains supply voltage.

#### **WARNING: THIS APPLIANCE MUST BE EARTHED.**

- This appliance should be wired into a 13A double pole switched fused spur outlet, having 3 mm contact separation and placed in an easily accessible position adjacent to the appliance. The spur outlet must still be accessible even when your oven is located in its housing.

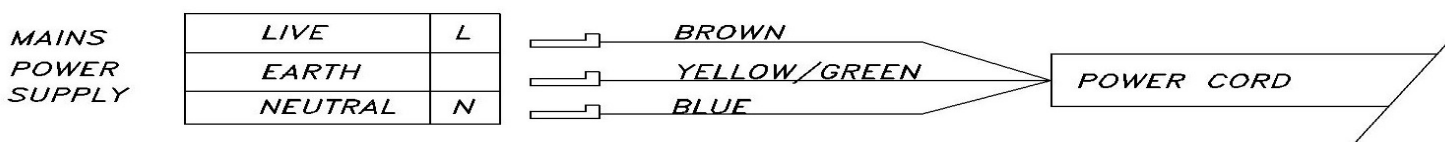

- To connect the oven power cord, loosen and remove the cover on the terminal block, in order to gain access to the contacts inside. Make the connection, securing the cord in place with the cable clamp provided and then immediately close the terminal block cover again.
- If you have to change the oven power cord, the earthing (yellow/green) conductor must always be 10 mm longer than the line conductors.
- Care must be taken to ensure that the temperature of the mains supply cable does not exceed 50°C.
- If the mains supply cable is damaged, then it must be replaced by an appropriate replacement which can be obtained from the Spares Department.

## Installing the oven into a kitchen cabinet

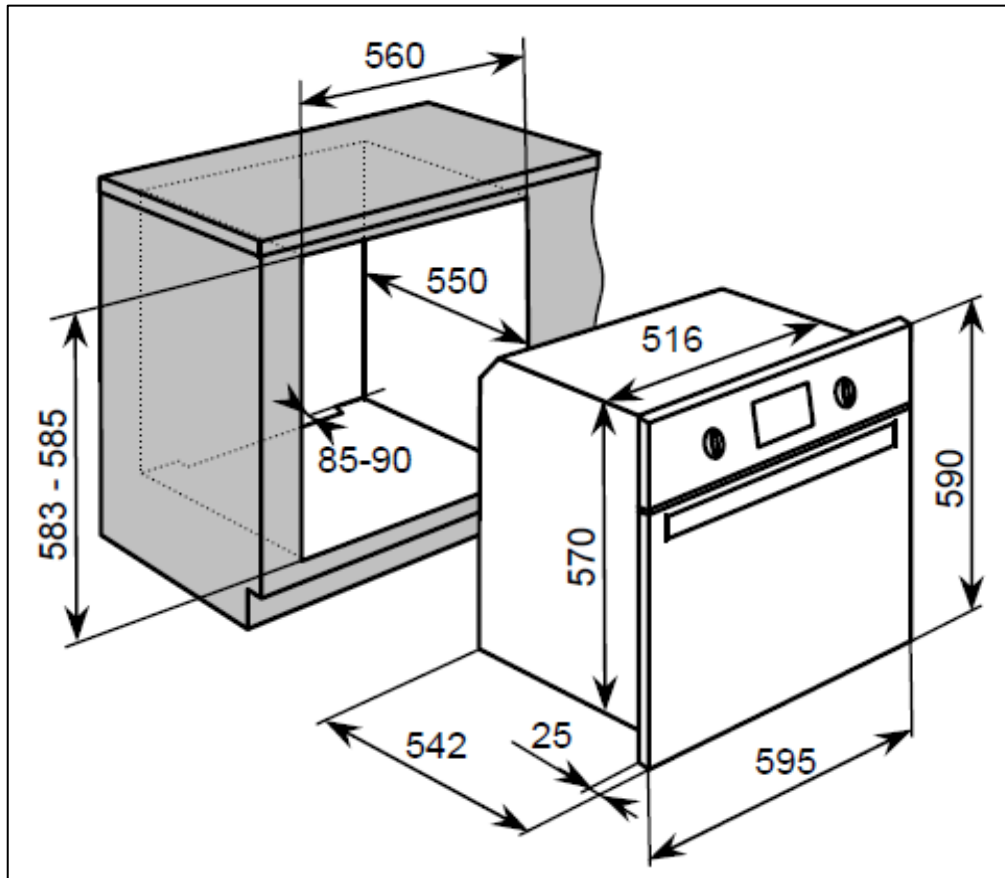

### Positioning the appliance

- Ensure that the aperture that you will be fitting the oven into is of the size given in the above diagram.
- The oven must be fitted into an oven housing with the ventilation cut-outs shown in the "Ventilation requirements" section on the next page.
- Ensure that the rear panel of the furniture housing unit has been removed.

## Ventilation requirements

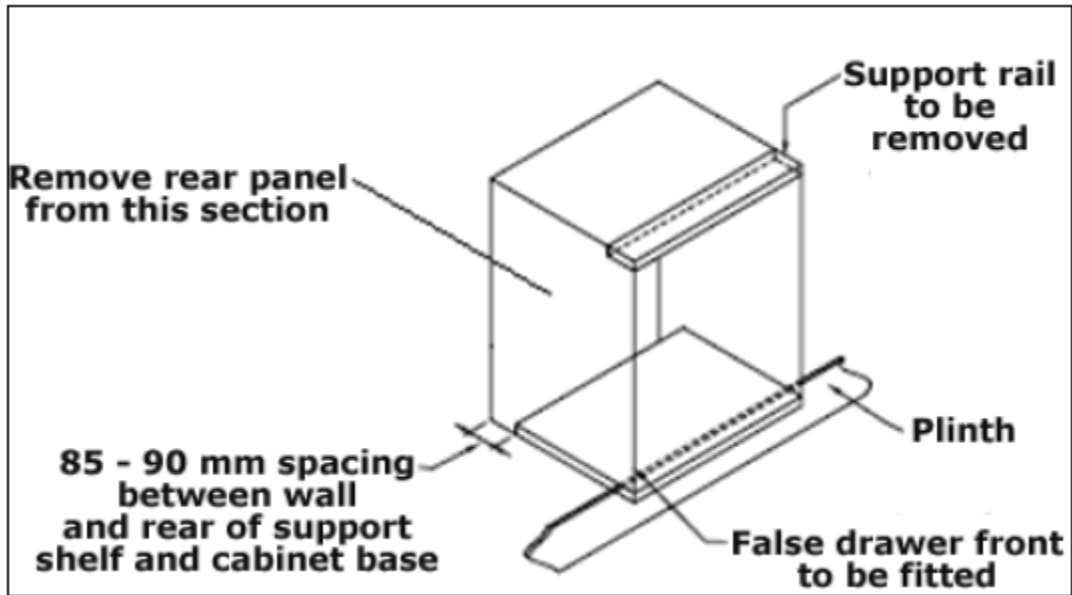

(Figure shows the ventilation and cut-out requirements for the installation of the appliance into a standard kitchen unit).

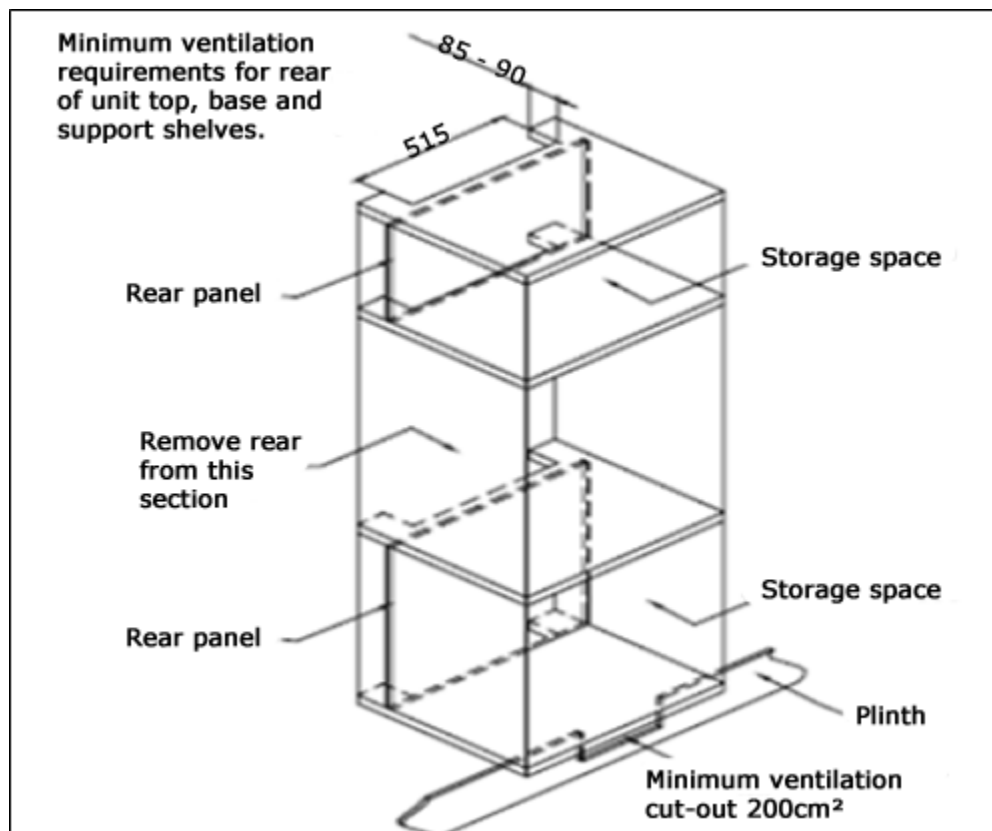

(Figure shows the ventilation and cut-out requirements for the installation of the appliance into a tall housing unit).

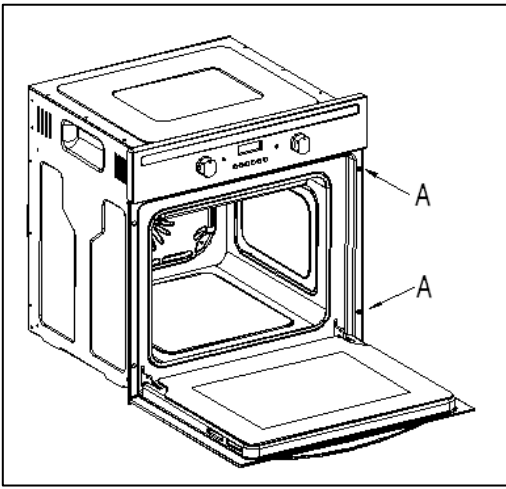

- Ensure that the oven has been securely fixed into the housing unit. The fixing of the oven into the housing is made by using four screws. These should be screwed through the oven cabinet and into the housing unit.

### **My appliance isn't working correctly**

- ***The oven isn't coming on.***
  - \* Check that the oven is in manual operation mode.
  - \* Check that you have selected a cooking function and a cooking temperature.
- ***There appears to be no power to the oven and grill.***
  - \* Check that the appliance has been connected to the electrical mains supply correctly.
  - \* Check that the mains fuses are in working order.
  - \* Check that the operating instructions for putting the appliance into manual operation mode have been followed.
- ***The grill function works but the main oven does not.***
  - \* Check that you have selected the correct cooking function.
- ***The grill and top oven element is not working, or cuts out for long periods of time during use.***
  - \* Allow the oven to cool for approximately 2 hours. Once cool, check whether the appliance is again working properly.
- ***My food is not cooking properly***
  - \* Ensure that you are selecting the correct temperature and the correct cooking function for the food that you are cooking. It may

be appropriate to adjust your cooking temperature by plus or minus 10°C, to achieve the best cooking results.

o ***My food is not cooking evenly***

- \* Check that the oven has been installed correctly and is level.
- \* Check that the correct temperatures and shelf positions are being used.

o ***The oven light is not working***

- \* Refer the "Replacing the oven bulb" section.

o ***I am getting condensation in my oven***

- \* Steam and condensation is a natural by product of cooking any food with high water content, such as frozen food, chicken etc.
- \* You may get condensation in the oven cavity and forming between the oven door glasses. This is not necessarily a sign that the oven is not working correctly.
- \* Do not leave food in the oven to cool after it has been cooked and the oven has been switched off.
- \* Use a covered container, where practical, when cooking to reduce the amount of condensation that forms.



***IMPORTANT: If your appliance appears not to be operating correctly, then you should disconnect it from your mains supply and then contact the Customer Care Department on telephone number (0118) 933 6911.***

***DO NOT ATTEMPT TO REPAIR THE APPLIANCE YOURSELF.***

Please note that if an engineer is asked to attend whilst the product is under guarantee and finds that the problem is not the result of an appliance fault, then you may be liable for the cost of the call out charge.

***The appliance must be accessible for the engineer to perform any necessary repair. If your appliance is installed in such a way that an engineer is concerned that damage will be caused to the appliance or your kitchen, then they will not complete a repair.***

***This includes situations where appliances have been tiled in, sealed in with sealant, have wooden obstructions placed in front of the appliance, like plinths. Or any installation other than the one specified by Baumatic Ltd has been completed.***

Please refer to the conditions of guarantee that appear on the warranty card that you receive with the appliance.

***IMPORTANT: Baumatic Ltd operates a policy of continuous improvement and reserves the right to adjust and modify its products without prior notification.***

## **Cooking tables – for BSO616SS**

The cooking tables below for each function should be viewed as a guide only. Other factors can influence cooking results such as food thickness, weight, shape and quality and personal preference.



*Fan oven*



<b><i>Food</i></b>	<b><i>Weight (kg)</i></b>	<b><i>Preheat time (mins)</i></b>	<b><i>Shelf position (from bottom)</i></b>	<b><i>Temperature (°C)</i></b>	<b><i>Cooking time (mins)</i></b>
Beef	1	15	2	200	40-50
Pork	1	15	2	200	70-80
Chicken	1.2	15	2	200	50-60
Duck	1.5	15	2	200	50-60
Steak	0.8	10	2	180	20-30
Bread	0.5	10	2	200	35-45



*Half grill*

<b><i>Food</i></b>	<b><i>Weight (kg)</i></b>	<b><i>Preheat time (mins)</i></b>	<b><i>Shelf position (from bottom)</i></b>	<b><i>Temperature (°C)</i></b>	<b><i>Cooking time (mins)</i></b>
Steak	0.8	10	3	250	20-25
Pork	0.8	10	3	250	25-30
Chicken	1.2	10	3	250	40-45
Sausage	0.6	10	4	250	15-20
Hamburger	0.6	10	4	250	15-20
Corn	1.2	10	3	250	20-25
Vegetables	0.5	10	4	250	15-20

# Cooking tables for BSO636-SS/WGL

COOKING TABLE			OVEN FUNCTIONS				
			 FAN COOKING		 CONVENTIONAL		
FOOD	WEIGHT (Kg)	PREHEAT <sup>(1)</sup> (min.)	TRAY LEVEL	TEMPERATURE °C ( )	TRAY LEVEL	TEMPERATURE °C ( )	TIME (min.)
<b>MEAT</b>							
Beef	1	15	2	200	2	220	40-50
Pork	1	15	2	200	2	220	70-80
Turkey	1.5	15	2	200	2	220	70-80
Lamb	1.5	15	2	200	2	220	70-80
Chicken	1.2	15	2	200	2	220	50-60
Duck	1.5	15	2	200	2	220	50-60
Rabbit	1	15	2	200	2	220	40-50
<b>FISH</b>							
Sirloin	0.8	10	2 (1 & 3)*	180	2 (1 & 3)*	200	20-30
<b>PASTA</b>							
Lasagna	1	15	2	200	2	220	20-30
Macaroni Cheese	1	15	2	200	2	220	30-40
<b>BREAD &amp; PIZZA</b>							
White Bread	0.5	10	2 (1 & 3)*	200	2	220	35-45
Multi Grain Bread	0.5	10	2 (1 & 3)*	200	2	220	20-30
Pizza	0.5	15	2 (1 & 3)*	200	2	220	15-20
<b>BAKERY</b>							
Cake with baking powder	0.7	10	2 (1 & 3)*	180	2	200	25-35
Apple Pie	1	15	2 (1 & 3)*	180	2	200	30-40
Strudel	1	15	2 (1 & 3)*	180	2	200	40-50
Fruit & Salad Tart	1.5	15	2 (1 & 3)*	180	2	200	35-45
Biscuits	0.7	15	1,2,4	180	2	200	25-35

(<sup>1</sup>) Ideally you should pre-heat the oven and not place food inside until the oven operating light has gone out.

(\*\*) Using the grill, the food should be turned half way through the cooking time.

OVEN FUNCTIONS					
COOKING TABLE					
FOOD	WEIGHT (Kg)	PREHEAT(*) (min)	TRAY LEVEL	TEMPERATURE (°C)	TIME (min)
<b>PASTA</b> Lasagne Pasta for Oven	1	15	2	200	40-45
	1	15	2	200	45-50
<b>BREAD &amp; PIZZA</b> White Bread Multi Grain Bread Pizza	0.5	10	1	200	10-15
	0.5	10	1	200	15-20
	0.7	15	2	200	20-25
<b>BAKERY</b> Cake with baking powder Fruit & Salad Tart Biscuits Bigne'	1.5	15	1	180	35-40
	1	15	1	180	40-45
	0.7	15	1,2,4	180	20-25
	0.7	15	1,2,4	180	20-25

(\*) You should pre-heat the oven and not place food inside of it until the oven operating light is switched off (for 10-15 minutes).

(\*\*) If using the pizza stone, this has to be pre-heated in the oven before use.



## Baumatic Consumables

- **BC001** Degreaser for Dishwashers (200 g)
- **BC002** Descaler for Washing Machines and Dishwashers (200 g)
- **BC003** Ceramic Hob Cleaner (250 ml)
- **BC004** Oven Cleaner (250 ml)
- **BC005** Stainless Steel Cleaner and Protector (250 ml)
- **BC007** E-Cloth – General Purpose Cloth
- **BC008** Microwave Cover

To order a Baumatic consumable product please call 0123 5437 244 and quote the product code. You can also order online from [eshop.baumatic.co.uk](http://eshop.baumatic.co.uk)



***United Kingdom***

Baumatic Ltd.,  
Baumatic Buildings,  
6 Bennet Road,  
Reading, Berkshire  
RG2 0QX  
United Kingdom

**Sales Telephone**

(0118) 933 6900

**Sales Fax**

(0118) 931 0035

**Customer Care Telephone**

(0118) 933 6911

**Customer Care Fax**

(0118) 986 9124

**Spares Telephone**

(01235) 437244

**Advice Line Telephone**

(0118) 933 6933

**E-mail:**

sales@baumatic.co.uk  
customercare@baumatic.co.uk  
spares@baumatic.co.uk  
technical@baumatic.co.uk

**Website:**

www.baumatic.co.uk

**Facebook:**

[www.facebook.com/baumatic.uk](http://www.facebook.com/baumatic.uk)

***Republic of Ireland***

**Service Telephone**

1-890 812 724

**Spares Telephone**

091 756 771

***Czech Republic/Slovakia***

Baumatic s.r.o.

Lípová 665/1  
460 01 Liberec 4  
Czech Republic

Panenská 34  
811 03 Bratislava - Staré Mesto  
Slovakia

+420 483 577 200 (CZ)

+421 255 640 618 (SK)

www.baumatic.cz

www.baumatic.sk

***Germany***

Kundendienst & Ersatzteile

Deutschland 0049(0)180-5888975

Oesterreich +43 (0) 820 / 420423

www.baumatic.de

***Italy***

Baumatic Italia S.R.L.  
Via Galvani N.3  
35011 Campodarsego (PD)

+3904 9920 2297

www.baumatic.it

***Holland***

Baumatic Benelux B.V.  
Dukdalfweg 15d  
1332 BH ALMERE  
Nederland

+31(0)36 549 1553/1555

www.baumatic.nl



