

GAS HOBS

USER AND INSTALLATION INSTRUCTIONS

B72TCBL-BX

B77TCBL-BX

AS9.1TCAL-BX



INSTALLATION INSTRUCTIONS

For future reference please record the following information which can be found on the Rating Plate and the date of purchase which can be found in the invoice:

Model Number

Serial Number

Date of Purchase

CONTENTS

General Information	page 3
Warning and Safety Instructions	page 4
Instructions for Use	pages 4-6
Instructions for Installation	Pages 6-10
Technical Data	Pages 10
Conditions of Guarantee	Back cover

INSTALLATION INSTRUCTIONS

GENERAL INFORMATION

Please read this booklet thoroughly before you use this appliance. It is important that you understand all the control functions before commencing to cook with your Baumatic appliance.

Please remember the advice and warnings shown on page 4, which is headed 'IMPORTANT – Warning and Safety Instructions'.

This appliance is designed for domestic household use when built into a kitchen worktop.
NOTE: The housing, adjacent furniture and all materials used in the installation must be able to withstand a minimum temperature rise of 85°C above ambient during periods of operation. This information is for guidance only and the actual withstand temperature will depend on the performance rating for the surface finish of the worktop.
Certain types of kitchen furniture surface finishes are particularly prone to heat damage or discoloration at temperatures lower than the above guidelines.
Installing the appliance in contravention of the guidance given, will be at the liability of the owner.

For use in Leisure Accommodation Vehicles, notice must be taken of the appropriate statement in the Installation Instructions (see page 7 – Important Note 5).

The use for any other purpose or in any other environment without the express agreement of Baumatic Ltd, would invalidate any warrantee or liability claim

Your new appliance is guaranteed against electrical or mechanical defects subject to certain exclusions noted in Baumatic Ltd Conditions of Guarantee.
The foregoing does not affect your statutory rights.

The Warrantee applies to Great Britain and Northern Ireland only.
In the event that you require any After Sales Service or advice, please contact the Baumatic Service Department on telephone number – 0118 933 6911.

Before using this appliance ensure that any protective packaging or coatings have been removed. To aid the protection of the environment, please sort the packing materials into different types and dispose of them in accordance with the local waste disposal laws.
Any further information can be obtained from your local Environment Agency office.
When first used, an odour may be emitted by any residual protective finish or moisture, which will cease after a short period of time.

This appliance has been constructed and distributed in compliance with the essential requirements of the following EEC DIRECTIVES and EUROPEAN NORMS :-

CE Marking – 93/68 Low Voltage – 73/23 Gas Products – 90/396 EMC – 89/336
Materials that can touch food – 89/109.
Safety Standards – EN 60 335-1, EN 60 335 – 2 – 6, EN 30-1-1.

As Baumatic have a policy of continued product improvement, the right is reserved to adjust and make any modifications deemed necessary without notification.

INSTALLATION INSTRUCTIONS

IMPORTANT NOTE – WARNING and SAFETY INSTRUCTIONS

This appliance complies with all current European safety legislation, however Baumatic do wish to emphasise that compliance does not remove the fact that surfaces will become hot during use and retain heat after operation.

Baumatic therefore strongly advise that babies and young children are prevented from being near or touching the appliance at any time.

If it is necessary for younger family members to be in the kitchen, that they are kept under close supervision at all times.

We also advise that great care is taken during use and cleaning operations.

Do make sure that the pan handles are always correctly positioned to avoid accidental contact.

Do not leave heated oil or fat unattended as there is a risk of fire.

Do use pans that are flat bottomed and the correct size for the heating area to be used (never smaller).

Do not allow electrical fittings or cables to be in contact with hot areas of the appliance.

Do not use the appliance for space heating or to dry clothes.

Do not install the appliance next to curtains or soft furnishings.

NOTE: This appliance must be correctly installed by a suitably qualified person, strictly in accordance with the manufacturer's instructions. For gas installations, the Installer must be Corgi registered (all Baumatic Engineers are Corgi registered) and for electrical installations, NICEIC registration is recommended.

Baumatic Ltd declines any responsibility for injury or damage to persons or property as a result of improper use or installation of this appliance.

Heat, steam and moisture will be created during use, take care to avoid injury and ensure that the room is adequately ventilated. If prolonged use occurs, additional ventilation may be required – please consult your Qualified Installer if you are in any doubt about the amount required.

INSTRUCTIONS FOR USE

These User Instructions should be retained for future reference and for use by a person who is perhaps unfamiliar with the appliance.

The following models are covered by these instructions:

**AS9.1TCAL-BX
B72TCBL-BX
B77TCBL-BX**

INSTALLATION INSTRUCTIONS

USING THE HOB

The symbols on the Control Panel fascias show which burner the Control Knob operates.

Dependent on the model there are two methods for igniting the burners.

1. Auto Ignition

After pressing in and turning the appropriate knob anti-clockwise to the large flame symbol, the ignition spark will operate as long as the knob is pressed down..

When a flame has been established the knob can be released.

2. Manual Ignition

After pressing in and turning the appropriate knob anti-clockwise to the large flame symbol, press the ignition button located on the control panel.

The ignition spark will operate as long as the button is held down. When a flame has been established, release the button.

To regulate the flame, continue turning anti-clockwise to the required setting between the large and small flame symbols.

To turn the burner off, turn fully clockwise.

NOTE:

When a Thermocouple Safety Device is incorporated in the appliance, it is necessary for the knob to be continuously held down for a further period of approximately 10 seconds after the flame has been established to enable the thermocouple to function.

The Safety Device is designed to stop the flow of gas to the burner head in the event of a flame out situation.

HELPFUL HINTS

Always use the correct diameter pan, one that is the same or slightly larger than the flame ring. The flame should never exceed the diameter of the pan.

The bottom of the pan should be flat and wherever possible, keep the lid on the pan when cooking.

Depending on the model the following burners are provided:

Large (Rapid or Triple Crown) – for rapid cooking or boiling large quantities of liquid

Wok – for rapid cooking or boiling large quantities of liquid

Medium (Semi-rapid) – for general cooking

Small (Auxiliary)– for slow or simmer cooking

Fish Kettle – for specialised cooking

All burners are variable between full and low positions

WARNING

Do not use commercial simmering aids as these can create excessive heat, which can damage the appliance.

INSTALLATION INSTRUCTIONS

CLEANING THE APPLIANCE

Always allow the appliance to cool down before cleaning to avoid a burn injury.

Do not use caustic or abrasive agents, coarse wire wool or hard tools as these can damage the surface finishes.

Normally, wiping with a soft cloth dampened with hot detergent solution is sufficient but for stubborn marks the following is recommended:

Vitreous Enamel parts – use only a cleaner that is recommended for this type of material.

Burner Assemblies – remove from the hob and soak for about 10 minutes in hot detergent solution. Rinse off and dry checking that the burner holes are not clogged, then reassemble in the correct order.

INSTRUCTIONS FOR INSTALLATION

This appliance must be installed by a competent person in accordance with the current versions of the following UK (United Kingdom) or ROI (Republic of Ireland) Regulations and Safety Standards or their European Norm Replacements.

Irish Standard for Domestic Gas Installations

NOTE: UK law stipulates that gas appliances must be installed and repaired by a CORGI Registered Installer (all Baumatic Engineers are CORGI Registered).

Gas safety Regulations (Installation & Use)

Building Regulations (issued by the Department of Environment)

Building Standards (Issued by the Scottish Development Department)

IEE Wiring Regulations

Electricity at Work Regulations

BS 6172 Installation of Domestic Gas Cooking Appliances

(if necessary, BS 5482 Installation of Domestic LPG Appliances)

BS 5440 Installation of Flues and Ventilation for Gas Appliances

Baumatic Ltd Installation Instructions

POSITIONING THE APPLIANCE

This appliance is classified as Class 3 and therefore is to be built into a kitchen unit (depending on size) or 600mm wide worktop, providing the following minimum distance is allowed:

- 700mm between the top surface and the underside of any horizontal surface above it.
- 50mm clearance around the appliance and combustible materials.

The surface finish of any adjacent unit must be capable of withstanding a minimum temperature of 85°C.

PRE-COMMISSIONING THE APPLIANCE

When unpacked, check that the following parts are included with the appliance:-

- Baumatic Ltd Instruction and Installation Book
- Pan Supports
- Burner Assemblies
- Adhesive sealing strip and fixing clamps & screws
- ½ BSP Elbow & Seal
- LPG conversion kit comprising an LPG jet for each burner and a self-adhesive label for amending Gas Category on the appliance Rating Label.

INSTALLATION INSTRUCTIONS

INSTALLATION NOTES

1. Cut the aperture to the dimensions shown below or use the template if printed on the packaging.
2. Invert the Hob and apply the sealing agent provided to match the outer perimeter edge.
3. If the sealing agent is a strip type, the protective covering must be removed from both sides. Do not leave a gap in the sealing agent or overlap the thickness.
NOTE: do not use any Silicone based sealant, as this can damage the worktop surface if repairs are required.
4. Insert the appliance into the aperture and fix in position via the clamps & screws, tightening the screws evenly (see Fig. 1 below).
5. If the appliance is to be installed in a Leisure Accommodation Vehicle, the requirements of EN 721 must be applied.

Fig. 1

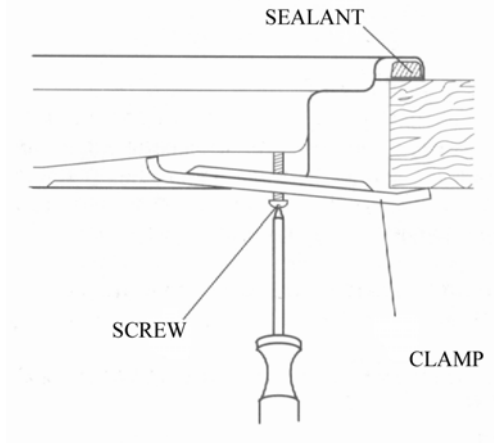

HOB APERTURE DIMENSIONS

MODEL	A	B	C	D	E
B72TCBL-BX	580	510	565	492	50
B77TCBL-BX	680	510	560	480	50
AS9.1TCAL-BX	680	510	560	480	50

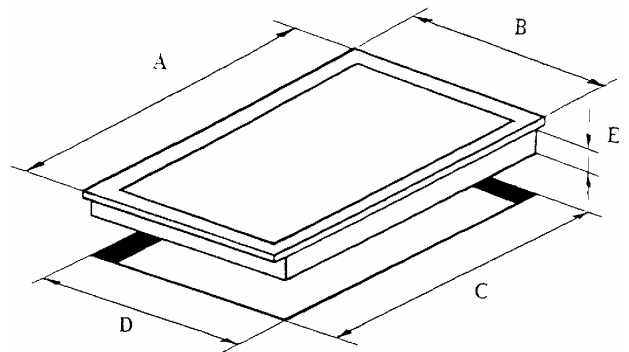

INSTALLATION INSTRUCTIONS

VENTILATION OF ROOMS

The room in which this appliance is installed must be well ventilated by natural or mechanical means, or a combination of both to ensure correct combustion and the removal of spent air. The minimum quantity of air for combustion will depend on the room volume, number of appliances and their total power rating.

The power rating of your appliance can be found by reference to the Rating Plate.

Note: The actual ventilation requirements must be determined by reference to the Statutory Regulations in force.

GAS CONNECTION

The gas supply must be connected by use of the ½ BSP Elbow, Seal and copper pipe and an isolation tap fitted in an easily accessible position.

The appliance as supplied is for use with Natural Gas, if it is to be adapted for LPG proceed as follows:

- Isolate the appliance from the electricity and gas supplies.
- Remove the pan supports and burner assemblies.
- Replace the injectors with the alternative type supplied.
- Use the appropriate thread sealant and check for gas soundness.
- Affix the self-adhesive label to the Rating Plate to amend the Gas Category.

Fig 2

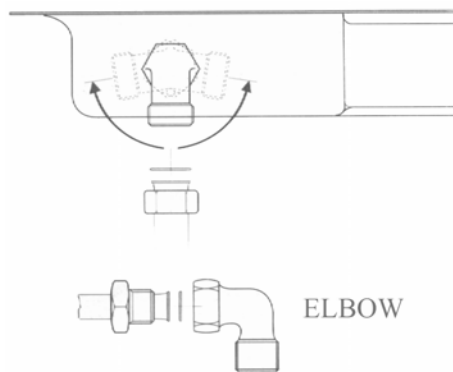
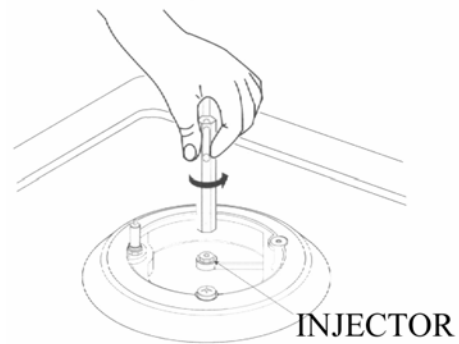

Fig 3



In order to adjust the minimum gas flow proceed as follows:

- Ignite the burner and turn down to the minimum setting.
- Remove the control knob from the gas tap.
- Adjust the flow either clockwise to decrease or anti-clockwise to increase the flame. Use a screwdriver inserted down the gas tap rod or via the screw head adjacent to the rod for models fitted with a Flame Supervision Device.
- Check that the flame is 3- 4 mm in length, bluish in colour, stable and noiseless, and does not extinguish when changing from maximum to minimum flow.
- Replace the control knob and check that all components have been reassembled correctly.

INSTALLATION INSTRUCTIONS

ELECTRICAL CONNECTION

Before connecting the appliance, make sure the supply voltage marked on the rating Plate corresponds with the mains supply voltage.

WARNING – THIS APPLIANCE MUST BE EARTHED

This appliance should be wired into a double pole Switched Fused Spur Outlet having 3 mm contact separation and the fuse rating reduced to 3 Amps.

IMPORTANT

The wires in the main supply lead are coloured in accordance with the following code:-

Green and Yellow	–	Earth
Blue	–	Neutral
Brown	–	Live

The connections must be made as follows:-

The wire coloured Green and Yellow must be connected to the terminal marked 'E' or the earth symbol (\perp) or coloured green and yellow.

The wire coloured Blue must be connected to the terminal marked 'N' or coloured blue or Black.

The wire coloured Brown must be connected to the terminal marked 'L' or coloured brown or red.

NOTE: The terminals marked 'SUPPLY' are for the mains supply wires and the terminations marked 'LOAD' are for the appliance wires.

The electrical outlet is to be positioned in an easily accessible position adjacent to the appliance. In the event that it is necessary to replace the mains supply lead, the replacement must conform to the specification listed in the Technical Data. Ensure that the colour code connection is correct and that all screws are tightened correctly.

MAINTENANCE

During the guarantee period, in case of need all service intervention should be referred back to the Baumatic Ltd Service department. Please note that intervention or repair by any unauthorised personnel will invalidate such guarantee,

Before carrying out any maintenance, disconnect the appliance from the gas and electricity supplies.

If a gas tap becomes stiff to operate, proceed as follows:

- Remove the control knobs, pan supports, burners and hob fixing screws & clamps.
- Remove the Hob from the worktop and remove any underside protective covers.
- Disconnect the fixings holding the tap to the fascia panel, separate the assembly, then clean the cone and seating with a cloth dampened with solvent.
- Lightly smear the cone with high temperature grease, reassemble into position and rotate a few times. Remove the cone again and remove any excess grease making sure that the gas ducts are not obstructed with grease.
- Carefully reassemble the components and check for gas soundness.

INSTALLATION INSTRUCTIONS

If it becomes necessary to replace the gas tap, proceed as follows:

- Disconnect the appliance as described above.
- Disconnect the gas pipe from the gas tap, disassemble from the gas rail by removing the fixing screws.
- When fitting a new tap, ensure that a new gasket is used.
- Re-connect the gas tap, check for gas soundness and reassemble the hob.

TECHNICAL DATA

ELECTRICAL DETAILS

Rated Voltage	230V ac 50Hz
Supply Connection	13A (double pole switched fused outlet with 3mm contact gap)
Power Input	0.008 to 0.02kW (depending on model)
Mains supply lead	3 x 0.75mm ² Type RR-F <HAR> marked

GAS DETAILS

Connection	Rp ½ (ISO R7)
Type	Natural Gas (20.9 mbar) – alternative LPG G30 (28-30 mbar) [Town Gas G110 – 120 (8 mbar) to order]

BURNER TYPES AND POWER INPUTS : kW

Model	Large	Medium	Small	Wok	Fish	Total KW
	Max / Min	Max / Min	Max / Min	Max / Min	Max / Min	
AS9.1TCAL-BX	3.0 / 0.7	1.75 / 0.4	1.0 / 0.35	3.5/1.7	-	11.0
B72TCBL-BX	-	1.75 / 0.4	1.0 / 0.35	3.5/1.7	-	8
B77TCBL-BX	3.0 / 0.7	1.75 / 0.4	1.0 / 0.35	3.5/1.7	-	11.0

JET SIZING CONVERSION TABLE: NATURAL GAS / LPG

Model	Large	Medium	Small	Wok	Fish
	NG / LPG	NG / LPG	NG / LPG	NG / LPG	NG / LPG
AS9.1TCAL-BX	1.15 / 0.85	0.97 / 0.65	0.72 / 0.50	1.35/0.72	-
B72TCBL-BX	-	0.97 / 0.65	0.72 / 0.50	1.35/0.72	-
B77TCBL-BX	1.15 / 0.85	0.97 / 0.65	0.72 / 0.50	1.35/0.72	-

BAUMATIC Ltd
CONDITIONS OF GUARANTEE

Dear Customer,

Included with your new Baumatic appliance is a guarantee registration card, please complete this and return at your earliest convenience.

This guarantee is in addition to your statutory legal rights and will not in any way hinder any legal rights.

The conditions of the guarantee, which applies, to your Baumatic appliance are as follows:

All 'Work' in relation to the Guarantee must be carried out by Baumatic Ltd or an approved service agent of Baumatic Ltd. Any claims made under the terms of the guarantee must be supported by the original invoice / bill of sale issued at the time of purchase.

The guarantee period starts from the date of the original purchase and the manufacturer will provide the parts and labour required to repair the appliance should breakdown occur as a result of mechanical / electrical failure. This service will be given Free of charge within the Guarantee period. An additional Insurance scheme is available should you wish to extend the warranty period.

For UK mainland and Northern Ireland only, an additional Insurance scheme is available should you wish to extend the warranty period.

This guarantee applies to UK mainland, Northern Ireland and ROI (Republic of Ireland) only.

THIS GUARANTEE DOES NOT COVER:

- Any damage caused by transit, misuse, or neglect.
- Cosmetic and perishable parts: plugs, fuses, light bulbs, light covers, cosmetic trims, cables, filters and attachments, knobs, any rubber and seals, ceramic or glass surfaces, dents, scratches, paintwork.
- Attachments / Accessories, trivets and handles, griddles, pan stands, shelves, burner caps and collars, oven liners. Plus any additions thereafter.
- Periodic maintenance, the repair or replacement of parts due to natural wear and tear.
- Material discoloration, corrosion.
- Incorrect installations, modifications or repair by any unauthorised personnel.
- Use of non-Baumatic parts.
- Damage caused by foreign objects or substances.
- Appliances used for non-domestic use.
- Operation on unsuitable voltage, water or gas supplies.
- Accidents, Civil war, acts of God or any cause beyond the control of Baumatic Ltd.

PLEASE NOTE ALL GUARANTEES ARE NON TRANSFERABLE

SALES	SERVICE	SPARES
TEL 0118 933 6900	TEL 0118 933 6911	TEL 0118 933 6922
FAX 0118 931 0035	FAX 0118 986 9124	

For UK mainland and Northern Ireland, please contact one of the above numbers for further information or any other query you may have.

For ROI (Republic of Ireland), please contact one of the numbers as below:

Tel: 01 – 4030501 Fax: 014030503

For further information or any other query you may have please contact one of the above numbers.

Thank you for buying Baumatic.