

**MG2/SB2/TG2 60cm
Front touch control
ceramic hob**

Instruction manual



User Manual for your Baumatic

MG2/SB2/TG2

60 cm Front touch control 4 hyperspeed zone ceramic hob.



You will be mine

NOTE: This User Instruction Manual contains important information, including safety & installation points, which will enable you to get the most out of your appliance. Please keep it in a safe place so that it is easily available for future reference; for you or any person not familiar with the operation of the appliance.

DD 17/10/06

Contents

Environmental note	4
Important safety information	5 – 8
Specifications	8 – 9
Ceramic hob surface layout	10
Control panel layout	10
Cooking zone indicators and neon's	11
Using the ceramic hob	11
Before first use	11
Touch controls	11
Turning the hob on	12
Turning on a zone and setting a power level	12
Turning on the dual circuit zones	12 – 13
Turning off a dual circuit's outer section	13
Turning off a zone gradually	13
Turning off a zone instantly	14
Turning the hob off	14
Residual heat indicator	14
Locking the hob top	15
Safety cut-off	15
Automatic pre-heating	16
Increasing the power level during automatic pre-heating	17
Switching off automatic pre-heating	17
The hob timer	17 - 18
Hob guidelines	18 - 19
Cleaning and maintenance	20
Cleaning the ceramic hob top	20
After each use	20
Cleaning table	20
Using a ceramic hob scraper	21
Using a specialist ceramic hob cleaner	21
Installation	22
Positioning	22
Unpacking the appliance	22
Installing the appliance	23 – 24
Electrical connection	25
Connecting the mains supply cable	25 – 26
Replacing the mains supply cable	26 - 27
My appliance isn't working correctly	27 – 28
Baumatic Ltd. Conditions of Guarantee	29
Contact details	30

This appliance is marked according to the European directive 2002/96/EC on Waste electrical and Electronic Equipment (WEEE). By ensuring this product is disposed of correctly, you will help prevent potential negative consequences for the environment and human health, which could otherwise be caused by inappropriate waste handling of this product.

The symbol  on the product, or on the documents accompanying the product, indicates that this appliance may not be treated as household waste. Instead it shall be handed over to the applicable collection point for the recycling of electrical and electronic equipment.

Disposal must be carried out in accordance with local environmental regulations for waste disposal.

For more detailed information about treatment, recovery and recycling of this product, please contact your local city office, your household waste disposal service or the shop where you purchased the product.



- The packaging materials that Baumatic uses are environmentally friendly and can be recycled.
- Please discard all packaging material with due regard for the environment.

Important safety information



Your safety is of the utmost importance to Baumatic. Please make sure that you read this instruction booklet **before** attempting to install or use the appliance. If you are unsure of any of the information contained in this booklet, please contact the Baumatic Technical Department.

General Information

- This appliance is designed for domestic household use and for the cooking and frying of domestic foodstuffs.
- **IMPORTANT:** The adjacent furniture and all materials used in the installation **must** be able to withstand a minimum temperature of 85°C above the ambient temperature of the room it is located in, whilst in use.
- Certain types of vinyl or laminate kitchen furniture are particularly prone to heat damage or discolouration at temperatures below the guidelines given above.
- Any damage caused by the appliance being installed in contravention of this temperature limit, **will be the liability of the owner.**
- Your new appliance is guaranteed against electrical or mechanical defects, subject to certain exclusions that are noted in Baumatic's Conditions Of Guarantee. The foregoing does not affect your statutory rights.
- The use of this appliance for any other purpose or in any other environment without the express agreement of Baumatic Ltd. will invalidate any warranty or liability claim.
- You should not use this appliance to store items on or as a work surface.
- No modifications to the appliance are permitted by Baumatic Ltd.
- You should not store or place flammable or highly flammable liquids/materials on top of or near the appliance. Items made from aluminium, plastic or plastic film should also be kept away from the appliance, as they may fuse to the surface.
- **Repairs may only be carried out by Baumatic Service Engineers or their authorised service agent.**

Child Safety

- Baumatic strongly recommend that babies and young children are prevented from being near to the appliance and not allowed to touch the appliance **at any time**. During and after use, all surfaces will become hot.
- If it is necessary for younger family members to be in the kitchen, please ensure that they are kept under close supervision at all times.
- Older children should only be allowed to utilise the appliance when supervised.

General Safety

- ✓ The appliance should only be installed and connected by a suitable qualified person.
- ✓ Care should be taken to ensure that the units and work surfaces that you build the appliance into, meet with the relevant standards.
- ✓ If you notice any scratches, splits or cracks in the ceramic glass, you should immediately switch off the appliance and disconnect it from your mains supply. Otherwise there is the risk of electric shock occurring.

During use

- ✓ Any film or stickers that are present on the hob surface when it is delivered should be removed before use.
- ✓ Care should be used when utilizing the appliance, otherwise there is a risk of burns being caused.
- You should not allow the electrical connection cables to come into contact with the hob surface when it is hot or any hot cookware.
- If fat and oil overheats, then it can ignite extremely quickly. For this reason, when cooking with fat and oil the appliance should not be left unattended.
- ✓ Make sure that all of the cooking zones are switched off after use.

Cleaning

- Cleaning of the hob should be carried out on a regular basis.
- **IMPORTANT:** Before attempting to clean the appliance, it should be disconnected from the mains and cool.
- Great care should be taken whilst using this appliance and when following the cleaning procedure.
- You should not use a steam jet or any other high pressure cleaning equipment to clean the appliance.

Installation



This appliance must be correctly installed by a suitably qualified person, strictly in accordance with the manufacturer's instructions. Please see the specific section of this booklet that refers to installation.

- **Baumatic Ltd. declines any responsibility for injury or damage, to person or property, as a result of improper use or installation of this appliance.**

Declaration of conformity

This appliance complies with the following European Directives:

- 73/23/EEC dated 19/02/1973 Low Voltage Directive.
- 89/336/EEC dated 03/05/1989 EMC Directive inclusive of Amending Directive 92/31/EEC.
- 93/68/EEC dated 22/07/1993 CE Marking Directive.
- 89/109/EEC dated 25/01/1992 Materials that can touch food.
- The manufacturer declares that the hob is built using certified materials and requires the appliance to be installed in accordance with the standards currently in force. This appliance must be used by a trained person for domestic purposes only.

To avoid damaging your appliance

- The ceramic glass can be damaged by objects falling onto it.
- The ceramic glass edge can be damaged by knocks from cookware.
- Cast iron and cast aluminium cookware with damaged bases may scratch the ceramic surface if they are dragged across it.

- Pans should be lifted on and off the hob surface and not dragged.
- Cooking zones should not be switched on without cookware placed on it. Also the cookware should not be empty.

Specifications

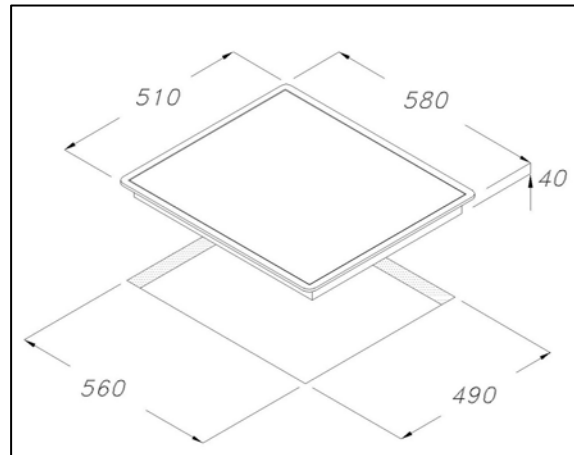

Product dimensions:

Height: 510 mm
 Width: 580 mm
 Depth: 40 mm

Aperture dimensions:

Height: 490 mm
 Width: 560 mm

Product specifications:

- 1 x 0.75/2.20 kW double hyperspeed zone (diameter 120/210 mm)
- 1 x 1.10/2.00 kW oval hyperspeed zone (diameter 170/265 mm)
- 2 x 1.20 kW hyperspeed zone (diameter 140 mm)
- Front touch control operation
- 4 individual residual heat indicators
- Safety lock
- Timer
- Wrap around designer frame

Standard accessories

- Ceramic hob scraper

Electrical details

Rated Voltage:	230 Vac 50 Hz
Supply Connection:	30 A (double pole switched fused outlet with 3mm contact gap)
Max Rated Inputs:	6.6 kW
Mains Supply Lead:	3 core x 6 mm ² (not supplied)

For future reference please record the following information which can be found on the rating plate and the date of purchase which can be found on your sales invoice. The rating plate of your hob is located on the underneath of the appliance. Therefore it is a good idea to record this information before you install your appliance.

Model Number

Serial Number

Date of Purchase

Ceramic hob surface layout

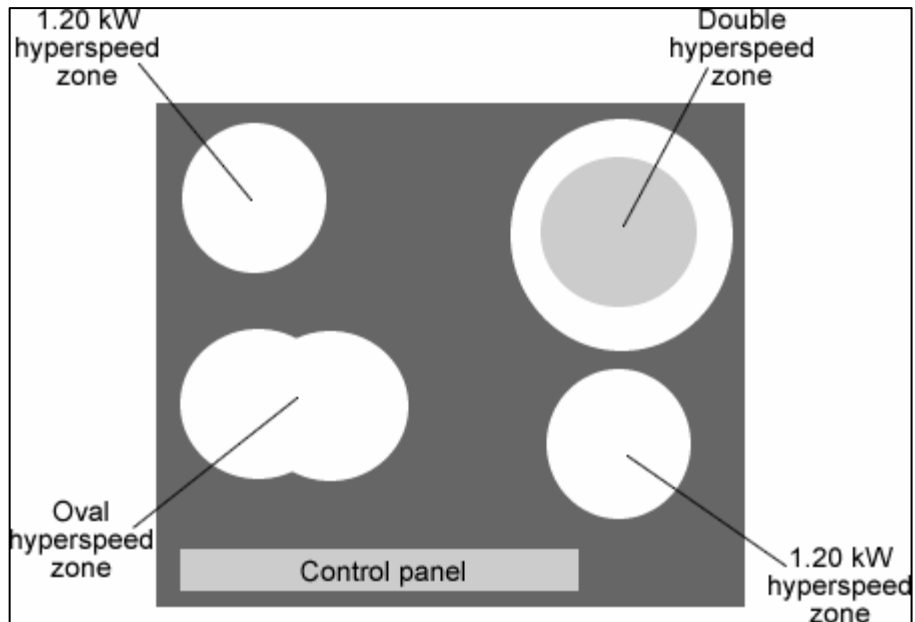

Control panel layout

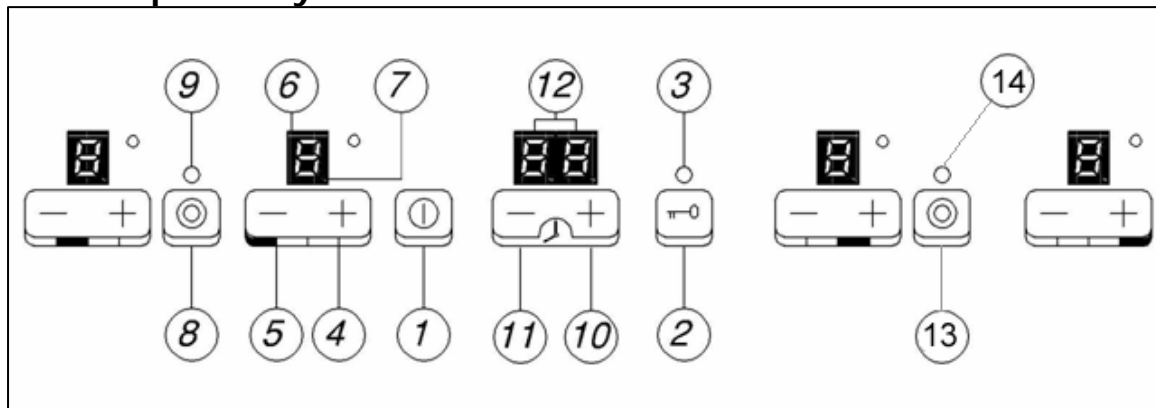

1. ON/OFF button
2. Safety lock button
3. Safety lock neon
4. Plus button
5. Minus button
6. Cooking zone indicator
7. Decimal point symbol
8. Oval hyperspeed zone dual circuit ON/OFF button
9. Oval hyperspeed zone dual circuit indicator neon
10. Timer plus button
11. Timer minus button
12. Timer display
13. Double hyperspeed zone dual circuit ON/OFF button
14. Double hyperspeed zone dual circuit indicator neon

Cooking zone indicators and neon's

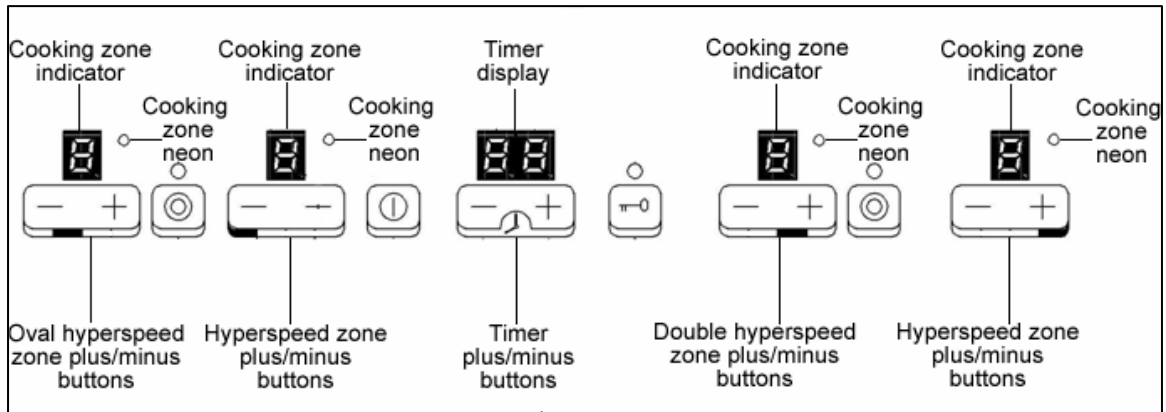

Using the ceramic hob

Before first use



IMPORTANT: You should clean the ceramic hob surface (see "Cleaning and maintenance" section).

- You should switch on one cooking zone at a time, for 5 minutes at the maximum setting. This will help to eliminate any new smell that exists and evaporate any humidity that has formed on the heating elements during transit.
- Do not burn off more than one zone at once.
- Do not place a pan on the ceramic hob until this burn off process has been completed.

Touch controls

- All operations are performed by means of the touch controls that can be found on the control panel.
- Each touch control has a visual display that corresponds to it.
- Every time you press a touch control, an acoustic signal will sound.

Turning the hob on

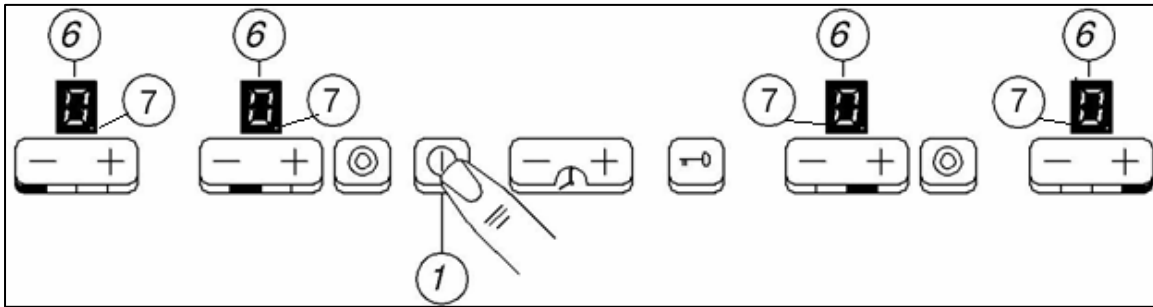

- When your mains supply is turned on, the safety lock will be switched on and the safety lock neon **(3)** will be lit. Press the safety lock button **(2)** and the safety lock will be turned off and the safety lock neon **(3)** will go out.
- Press the ON/OFF button **(1)**
- The cooking zone indicators **(6)** will all read "0".
- The decimal point symbols **(7)** will flash on and off.

Turning on a zone and setting a power level

IMPORTANT: A zone must be selected within 10 seconds of turning the hob on.

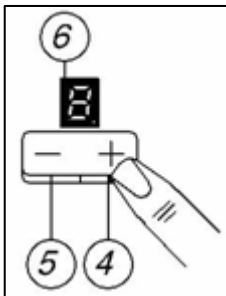

- Press the plus **(4)** button for the zone that you want to use.
- Adjust the zone between power levels 1 and 9, using the plus **(5)** and minus **(4)** buttons. By holding down either of these buttons, the value on the zone indicator **(6)** will adjust up or down every 0.3 seconds.

Turning on the dual circuit zones

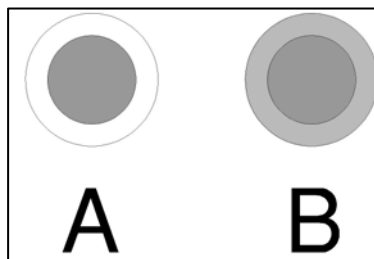

The double hyperspeed zone has two cooking areas that you can use, a central section and an outer section. You can use the central section **(A)** independently or both sections **(B)** at once.

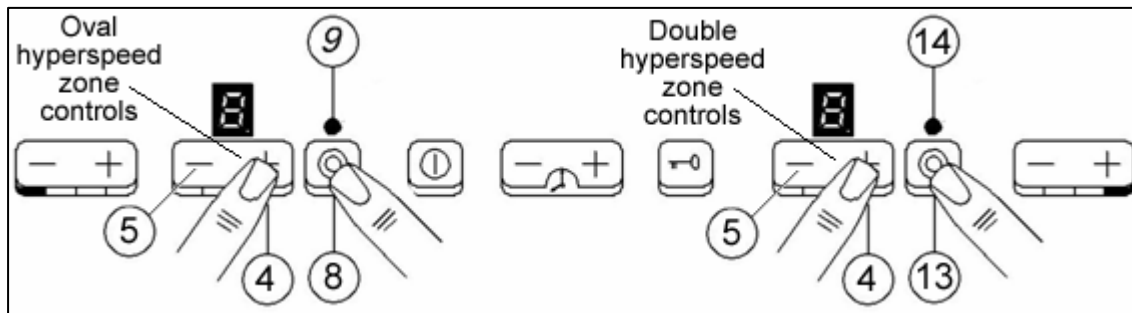

- Adjust the oval hyperspeed or double hyperspeed zone between power levels 1 and 9, using the plus **(4)** and minus **(5)** buttons.
- The central section is switched on.
- If you wish to also activate the outer section of the oval hyperspeed zone, you should press the oval hyperspeed zone dual circuit ON/OFF button **(8)**. The oval hyperspeed zone dual circuit indicator neon **(9)** will light.
- If you have switched on the central section of the double hyperspeed zone, to activate the outer section. You should press the double hyperspeed zone dual circuit ON/OFF button **(13)**. The double hyperspeed zone dual circuit indicator neon **(14)** will light.

Turning off a dual circuit's outer section

- Both zones of the dual circuit must be switched on.
- For the oval hyperspeed zone, press the oval hyperspeed zone dual circuit ON/OFF button **(8)**.
- The dual circuit indicator neon **(9)** will go out and the outer section will switch off.
- For the double hyperspeed zone, press the double hyperspeed zone dual circuit ON/OFF button **(13)**.
- The dual circuit indicator neon **(14)** will go out and the outer section will switch off.

Turning off a zone gradually

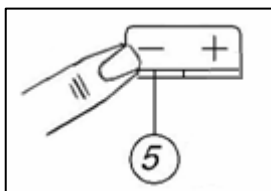

- Press the minus button **(5)** until the number in the cooking zone indicator reaches "0". After 3 seconds, the zone will switch off automatically.

Turning off a zone instantly

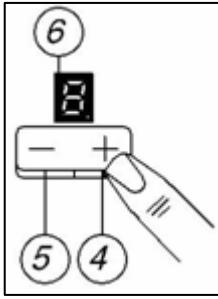

- Press the minus button **(4)** and the plus button **(5)** simultaneously.
- The zone will switch off immediately.
- An “H” will show in the cooking zone indicator **(6)**, alternating with “0”. (See the section on the “residual heat indicator” below).

Turning the hob off

Once you have switched off all of the cooking zones, you should turn off the hob.

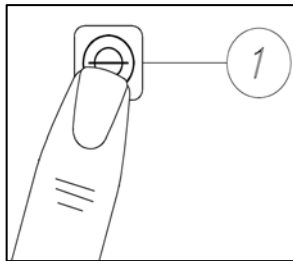

- Press the ON/OFF button **(1)**.

It is possible to turn the hob off at any time by pressing the ON/OFF button **(1)**.

Residual heat indicator

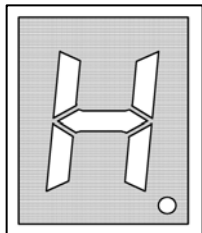

- After a zone is switched off, the corresponding cooking zone indicator **(6)** will show the letter “H”, alternating with “0”. This means that the temperature of the zone is over 60°C and is therefore high enough to cause injury.
- If you switch off the appliance using the ON/OFF button **(1)** then only the “H” will appear in the cooking zone indicator **(6)**.
- When the temperature falls below 60°C, then the letter “H” and “0” will stop alternating (if the hob is still switched on), or the “H” will go out (if the hob is not switched on).
- **IMPORTANT:** The residual heat indicator will disappear if your mains supply is cut.

Locking the hob top

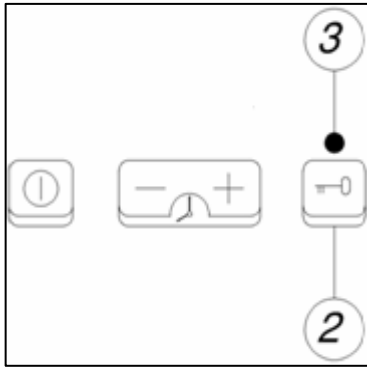

- The whole hob top can be locked by pressing the safety lock button **(2)** whilst the appliance is turned on.
- The safety lock neon **(3)** will light to show that the safety lock feature has been switched on.
- When the safety lock feature is activated, it will disable any of the other buttons on the control panel, except the ON/OFF button **(1)**.
- To disable the safety lock feature, you should press the safety lock button **(2)** again. The safety lock neon **(3)** will go out and you are then able to adjust the power of any zone on the hob top.
- **IMPORTANT:** If the appliance is switched off whilst the safety lock feature is activated, then it will still be activated the next time that you turn the appliance on. Therefore before you can turn on a zone and set it to a power level, you will need to deactivate the safety lock by pressing the safety lock button **(2)**.

Safety cut-off

- If one or more of the cooking zones are accidentally left on, a safety cut off will activate after a certain period of time. The length of time depends on the power level that a zone or zones have been set on.

LEVEL	TIME LIMIT
1	10 hours
2 – 3	5 hours
4	4 hours
5	3 hours
6 – 8	2 hours
9	1 hour

- If the safety cut off has activated, the symbol "H" will appear in the cooking zone indicator **(6)** that applies to the cooking zone that has been left on. To reset the appliance, you should press the ON/OFF button **(1)**.
- If the plus **(4)** or minus **(5)** buttons are pressed, then the length of time before the safety cut-out will activate is reset.

Automatic pre-heating

- This feature will set a cooking zone to maximum power and will then automatically set the cooking zone to a power level that you have selected after a certain period of time.

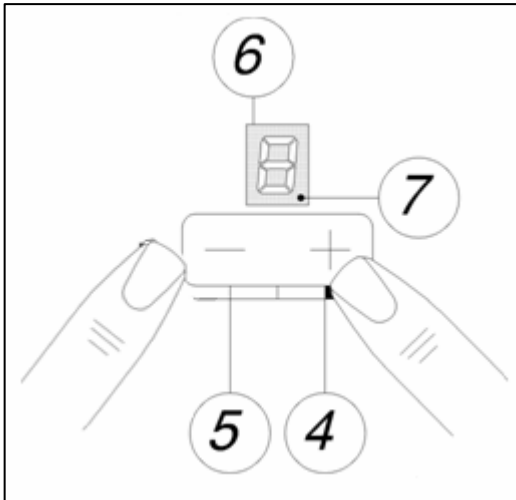

- Press the minus button **(5)** once and power level 9 appears on the cooking zone indicator **(6)**, then release the minus button.
- Press the plus button **(4)** once and a flashing decimal point symbol will appear on the cooking zone indicator **(6)**, then release the plus button.
- Use the minus button **(5)** to adjust the zone to the power level that you want to cook at.
- When the minus button **(5)** is released, the decimal point will stop flashing and the power level that you have selected will appear on the cooking zone indicator **(6)**.
- Once the automatic pre-heating time period is over, the hob will beep once and the decimal point symbol will go out. Only the actual power level will show on the cooking zone indicator **(6)**.
- The period of time that a zone will automatically pre-heat for before dropping to the actual power level, is shown in the table below: -

LEVEL	TIME LIMIT
1	1 minute 11 seconds
2	2 minutes 44 seconds
3	4 minutes 47 seconds
4	5 minutes 28 seconds
5	6 minutes 29 seconds
6	1 minutes 11 seconds
7	2 minutes 44 seconds
8	2 minutes 44 seconds
9	N/A

Increasing the power level during automatic pre-heating

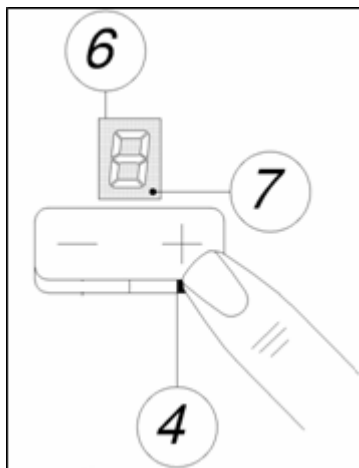

- If a zone is already within automatic pre-heating mode and you wish to adjust the power level.
- Increase the power level by pressing the plus button (4).
- The pre-heating time will be adjusted. It will take into account the amount of time that has already elapsed.

Switching off automatic pre-heating

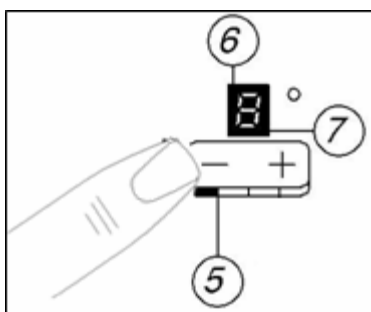

- If a zone is already within automatic pre-heating mode and you wish cancel it.
- Press the minus button (5), the automatic pre-heating mode will then be cancelled and you can use the hob in normal operation once more.

- **IMPORTANT:** Please note that switching off automatic pre-heating will not switch off the zone, it will still be necessary for you to do this manually.

The hob timer

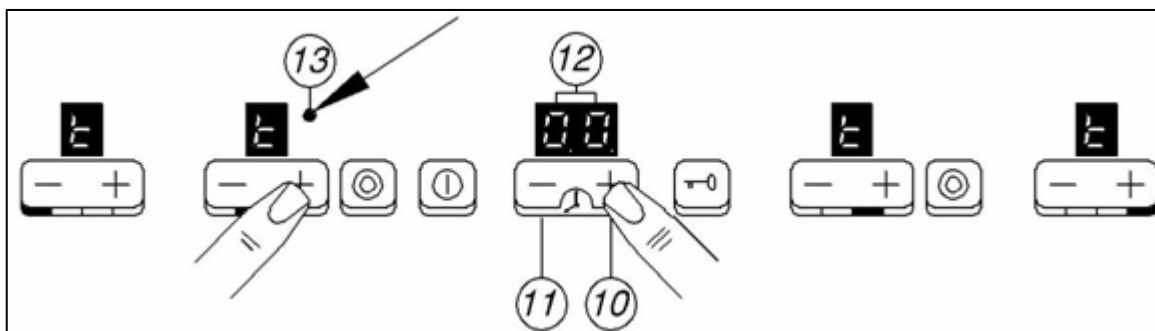

- Touch either the plus (10) or minus (11) buttons of the timer. If you press the minus button (11) "99" will appear on the timer display (12), if you press the plus button (10) "00" will appear on the timer display (12). A "t" symbol will appear on all the cooking zone indicators.

- After selecting the timer, a zone must be selected within 10 seconds by pressing one of the plus **(4)** or minus **(5)** buttons. You should use these buttons to select your desired power level.
- The zone will switch on and start to heat, a light **(13)** will switch on next to the relevant cooking zone indicator **(6)**.
- Use the plus **(10)** and minus **(11)** buttons to adjust the time that appears in the timer display **(12)**.
- Once the minus or plus buttons are released, the countdown will start immediately.
- The timer will be assigned to the zone that you have switched on.
- You can adjust the time that has been set, by using the plus **(10)** or minus **(11)** buttons for the timer.
- At the end of the time period that has been set, an acoustic signal will sound that lasts for 30 seconds, "00" will flash on the timer display **(12)** and the selected zone will switch off.
- To cancel the audible alarm, press either the minus **(11)** or plus **(10)** buttons for the timer.
- The timer can only be used for one zone at a time. Any other zones that you have in use will not switch off at the end of the countdown time.
- If you wish to cancel the timer setting before it reaches the end of the countdown period, press the plus **(10)** and minus **(11)** buttons of the timer simultaneously.
- **IMPORTANT:** If you cancel the timer setting, the selected zone will still remain on, therefore you will need to turn the zone off manually.

Hob guidelines

- The first few times the hob top is used, it may give off an acrid, burning smell. This smell will disappear completely with repeated use.
- The hob surface is fitted with cooking areas of different diameter and power.
- The positions where the heat will radiate from are clearly marked on the hob top. The saucepans must be positioned exactly on

- these zones for efficient heating to occur. Pans should have the same diameter as the cooking zone that they are being used on.
- You should not use saucepans with rough bottoms, as this can scratch the ceramic surface.
 - Before use, make sure that the bottoms of the saucepans are clean and dry.
 - When cold, the bottom of the pans should be slightly concave, as they expand when hot and lie flat on the surface of the hob. This will allow the heat to transfer more easily.
 - The best thickness for the bottom of the pans is 2 – 3 mm of enameled steel and 4 – 6 mm for stainless steel with sandwich type bottoms.
 - If these rules are not followed, then there will be a great loss of heat and energy. Heat not absorbed by the saucepan, will spread to the hob, frame and surrounding cabinets.
 - Preferably cover pans with a lid to permit cooking at a lower heat.
 - Always cook vegetables and potatoes, etc. in as little water to reduce cooking times.
 - Food or liquid that has high sugar content may damage the hob top if it comes into contact with the ceramic hob surface. Any spillages should be wiped up immediately, however this may not prevent the hob surface from becoming damaged.
 - **IMPORTANT:** The ceramic hob surface is tough; however it is not unbreakable and can be damaged. Especially if pointed or hard objects are allowed to fall on it with some force.
 - **DO NOT USE THE HOB IF THE SURFACE BECOMES BROKEN OR CRACKED. YOU SHOULD CONTACT THE BAUMATIC SERVICE DEPARTMENT IMMEDIATELY.**

Cleaning and maintenance



Cleaning operations must only be carried out when the oven is cool.

The appliance should be disconnected from your mains supply before commencing any cleaning process.

Cleaning the ceramic hob top



Any residues that are left on the hob top surface from cleaning agents **will** damage it. You should remove any residues with water and a little washing up.



Abrasive cleaners or sharp objects will damage the hob surface; you should clean it using water and a little washing up liquid.



Although it is easier to clean some deposits whilst the hob surface is still warm. You should take care not to burn yourself if cleaning the hob surface when it is still warm.

After each use

- Wipe the appliance over with a damp cloth and a little washing up liquid.
- Dry the appliance by rubbing the surface with a clean cloth.

Cleaning table

Type of deposit	Remove immediately?	Remove when the appliance has cooled down?	What should I use to remove the deposit?
Sugar or food/liquid containing sugar	Yes	No	Ceramic hob scraper
Tin foil or plastic	Yes	No	Ceramic hob scraper
Fat splashes	No	Yes	Ceramic hob cleaner
Metallic discolourations	No	Yes	Ceramic hob cleaner
Water splashes or water rings	No	Yes	Ceramic hob cleaner

Using a ceramic hob scraper

Your appliance will be provided with your appliance. The following guidelines should also be followed when using the ceramic hob scraper: -

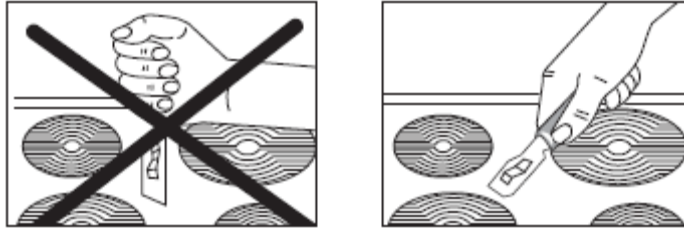

- The scraper should be placed on the ceramic surface at an angle.
- Residues should be removed by sliding the blade carefully over the ceramic surface.
- The ceramic surface should be wiped with a damp cloth and a small amount of washing up liquid.
- Dry the appliance by rubbing the surface with a clean cloth.

Using a specialist ceramic hob cleaner

It is possible to purchase specialist ceramic hob cleaner/conditioner.

You should follow the instructions given by the manufacturer of the specialist ceramic hob cleaner. You should ensure that it is suitable for use on your appliance.

Installation



The installation must be carried out by a suitably qualified person, in accordance with the current version of the following.

- **UK Regulations and Safety Standards or their European Norm Replacements.**
- **Building Regulations** (issued by the Department of the Environment).
- **Building Standards** (issued by the Scottish Development Department).
- **IEE Wiring Regulations.**
- **Electricity At Work Regulations.**

Positioning



The adjacent furniture must be able to withstand a minimum temperature rise of 85°C above the ambient temperature of the room it is located in, during periods of use.

This appliance is classified as Class 3 and therefore is to be built into a kitchen unit (depending on size) or 600 mm worktop, providing the following minimum distances are allowed:

- 700 mm between the hob surface and the underside of any horizontal surface above it.
- 50 mm clearance around the appliance and between the hob surface and any combustible materials.

Unpacking the appliance

When unpacking the appliance please check that the following items are contained within the packaging:

- 1 Baumatic hob
- 1 Ceramic hob scraper
- 1 Installation and instruction manual
- 1 Baumatic guarantee card
- 4 Fixing brackets
- 4 Fixing screws
- 4 Spring clips
- 1 Sealing strip

Installing the appliance

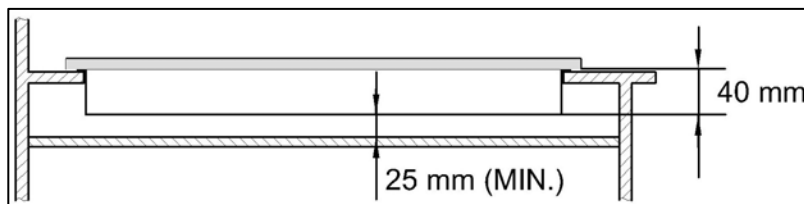
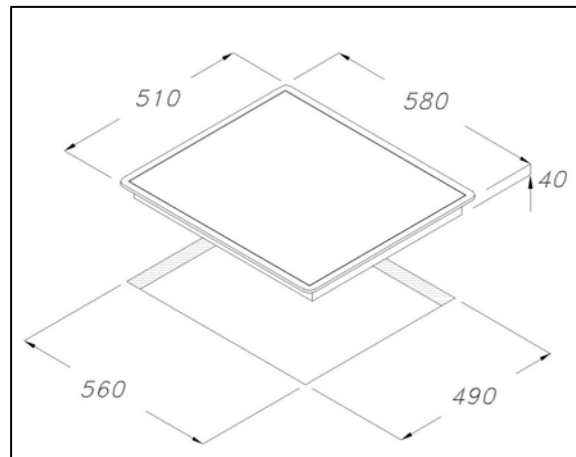

- Cut a hole in the worktop that corresponds with the drawings shown above.
- **IMPORTANT:** You must have a gap of at least 25 mm between the underneath of the appliance and any surface that is below it.

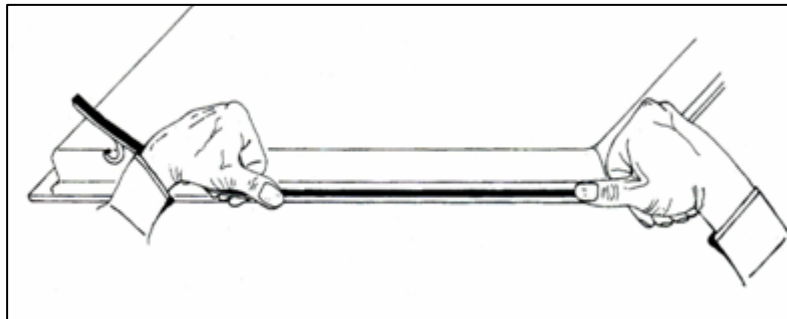

- Carefully turn the hob upside down and place it on a cushioned mat.
- Apply the sealing strip provided around the edge of the appliance.
- The protective covering must be removed from both sides.
- Do not leave a gap in the sealing agent or overlap the thickness.
- **IMPORTANT:** Do not use a silicon sealant to seal the appliance against the aperture. This will make it difficult to remove the hob from the aperture in future, particularly if it needs to be serviced.

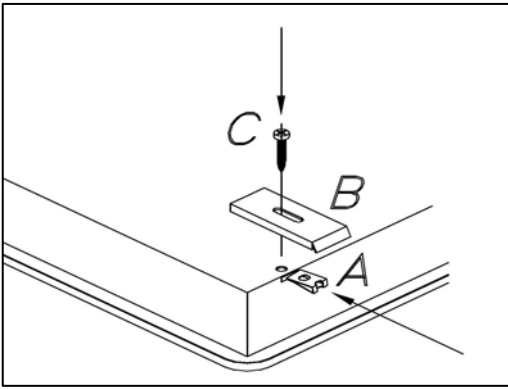

- (A) Clip
- (B) Fixing bracket
- (C) Screw

- You should insert a clip **(A)** into the holes which are located in each corner of the hob.
- Place the fixing brackets **(B)** over each hole and clip, and then place a screw **(C)** through the hole and fixing bracket **(B)**. Tighten the screws a little way, so that they stay in place.
IMPORTANT: Do not tighten the screws fully.
- Carefully turn the hob back over and then gently lower it into the aperture hole that you have cut out.

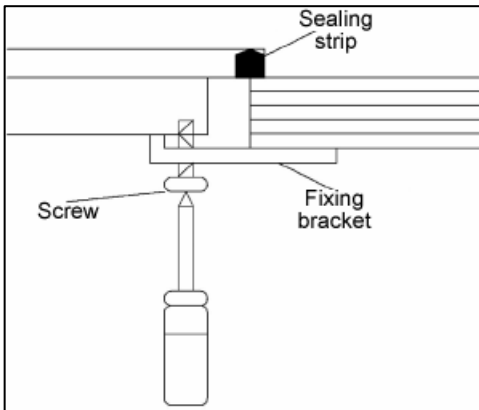

- On the underneath of the hob, locate the fixing brackets **(B)** and turn them so that they locate on the underneath of the worktop and the hob.
- Fully tighten the screws **(C)** to secure the hob into position.

Electrical connection



This appliance must be installed by a qualified person in accordance with the latest edition of the I.E.E. Regulations and in compliance with Baumatic's instructions.

Before connecting the appliance, make sure that the supply voltage marked on the rating plate corresponds with your mains supply voltage.

WARNING: THIS APPLIANCE MUST BE EARTHED.

- This appliance must be wired into a 30 A double pole switched fused spur outlet, having 3 mm contact separation and placed in an easily accessible position adjacent to the appliance. It should not be located above the appliance and no more than 1.25m away from it.
- The spur outlet must still be accessible even when your oven is located in its operating position.
- Cable type: H05 RRF 3 core x 6 mm²

Connecting the mains supply cable

- The mains terminal block is located on the underside of the hob and the terminals are accessible by removing the terminal block cover by removing the cover screw.

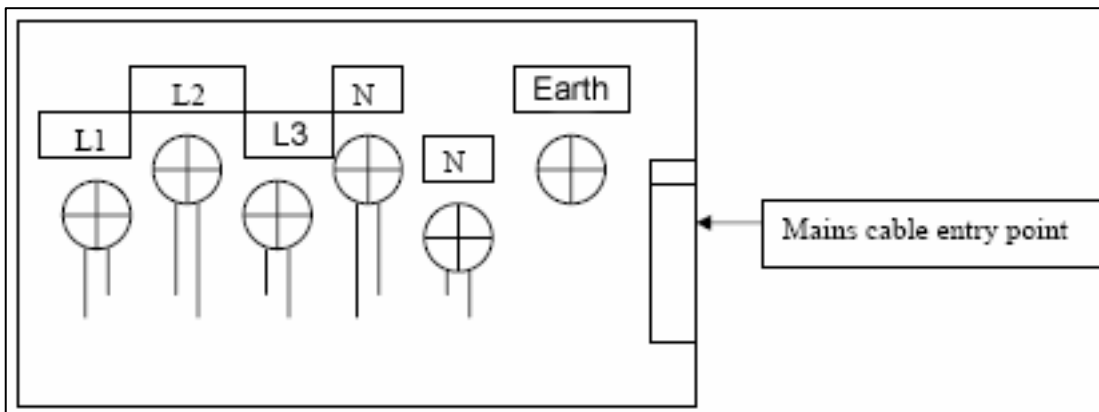

- The cable connections must be in accordance with the diagram located on the bottom of the hob.

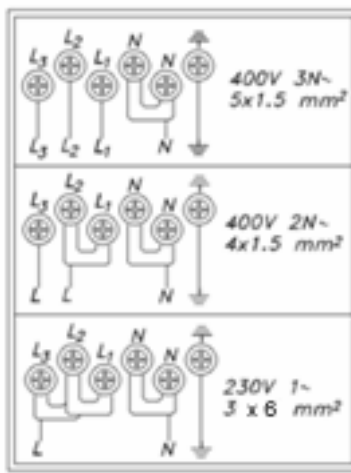

- The brass links must be positioned as marked in the appropriate diagram and once established ALL terminal screws must be tightened down firmly.
- **If when the hob is first switched on, only two of the zones work, you should recheck that the terminal screws are all fully tightened between the links. This should be done before contacting the Baumatic Service Department.**
- **IMPORTANT:** The appliance must NOT be connected to the mains supply by means of a 13A plug and socket.
- The cable can be looped if necessary, but make sure that is not kinked or trapped when the hob is in position. Care must be taken to avoid the cable being in contact with hot parts of the appliance.

Replacing the mains supply cable

If the mains supply cable is damaged, then it must be replaced by an appropriate replacement which can be obtained from the Baumatic Spares Department.

The mains supply cable should be replaced in accordance with the following instructions:

- **Switch the appliance off at the control switch.**
- Open the terminal block on the underside of the hob.
- Unscrew the terminal screws fixing the cable.
- Replace the cable with one of the same length and in accordance with the specification given above.

- The “green-yellow” earth wire must be connected to the terminal marked \perp . It must be about 10 mm longer than the live and neutral wires.
- The “blue” neutral wire must be connected to the terminal marked with letter (N) - the live wire must be connected to the terminal marked with letter (L).

My appliance isn't working correctly

- **The cooking zones are not functioning or will not switch on.**
 - * It has been more than 10 seconds since the appliance was switched on. You should switch the appliance on again, using the ON/OFF button.
 - * The safety lock has been switched on (see the “Locking the hob top” section for information on how to turn off the safety lock).
 - * Several cooking zone selection buttons have been pressed at once. You should only touch one cooking zone selection button at once.
 - * The safety cut out has been triggered. Press the ON/OFF button **(1)** to reset the appliance.
 - * Check that the mains electrical supply to the appliance is correct and working. Check the mains fuse.
- **The residual heat indicator has not come on after I have switched a cooking zone off.**
 - * The cooking zone has only been turned on for a short period of time; therefore it did not go above 60°C.
 - * **IMPORTANT:** If the cooking zone does appear to be hotter than 60°C and the residual heat indicator has not come on, you should call the Baumatic Service Department.
- **A humming sound is heard when a cooking zone is selected.**
 - * This is normal; the sound will disappear when the zone heats up.

- **The cooking zones have become discoloured**
 - * This maybe caused by burnt on remnants of food. This will not affect the working of the appliance. However you should make sure that the cleaning instructions are being followed regularly.
- **Only two of the zones on my hob are working**
 - * You should recheck that the terminal screws are all fully tightened between the links.



IMPORTANT: If your appliance appears not to be operating correctly, then you should disconnect it from your mains supply and then contact the Baumatic Service Department on telephone number (0118) 933 6911.

DO NOT ATTEMPT TO REPAIR THE APPLIANCE YOURSELF.

Please note that if an engineer is asked to attend whilst the product is under guarantee and finds that the problem is not the result of an appliance fault, then you may be liable for the cost of the call out charge.

The appliance must be accessible for the engineer to perform any necessary repair. If your appliance is installed in such a way that an engineer is concerned that damage will be caused to the appliance or your kitchen, then he will not complete a repair.

This includes situations where appliances have been tiled in, sealed in with sealant, have wooden obstructions placed in front of the appliance, like plinths. Or any installation other than the one specified by Baumatic Ltd. has been completed.

Please refer to the conditions of guarantee document on page 29 of this instruction manual for clarification of this.

Baumatic Ltd. Conditions of Guarantee

Dear Customer,

Your new Baumatic appliance comes complete with a free 12 month guarantee covering both parts and labour costs resulting from defective materials or workmanship.

Baumatic also gives you the opportunity to automatically extend the guarantee period for a further 12 months at no extra cost, giving an initial guarantee period of 24 months. The extended guarantee period applies to England, Scotland, Wales and Northern Ireland only.

To qualify for your full 24 months guarantee you **must** register your appliance within 28 days of purchase to be covered under this guarantee. This can be done online via: www.baumatic.co.uk or through returning the guarantee card which can be found in each new Baumatic appliance.

* In addition, your appliance is covered by a 5 year parts warranty. Baumatic Ltd will provide free of charge the parts required to repair the appliance, only if they are fitted by a Baumatic engineer, for any defect that arises due to faulty materials or workmanship within a period of 5 years from the original purchase date.

* An additional 1 to 3 year insurance scheme for labour is available should you wish to extend the warranty period.

Should any person other than an authorised representative of Baumatic Ltd interfere with the appliance, the policy is negated and Baumatic Ltd will be under no further liability.

The guarantee covers the appliance for normal domestic use only, unless otherwise stated.

Any claims made under the terms of the guarantee must be supported by the original invoice/bill of sale issued at the time of purchase.

This guarantee is transferable only with the written consent of Baumatic Ltd.

If the appliance fails and is considered either not repairable or uneconomical to repair during the manufacturer warranty period, a free of charge replacement will not be offered.

The guarantee for any replacement will only be for the remainder of the guarantee on the original product purchased.

The guarantee does not cover:

- Sinks and taps
- Failure to comply with the manufacturers instructions for use.
- The replacement of cosmetic components of accessories
- Accidental damage or wilful abuse.
- Subsequent loss or damage owing to the failure of the appliance or electrical supply
- Incorrect installation
- Losses caused by Acts of God, civil war, failure to obtain spare parts, strikes or lockouts
- Filters, fuses, light bulbs, external hoses, damage to bodywork, paintwork, plastic items, covers, baskets, trays, shelves, burner bases, burner caps, decals, corrosion, rubber seals.

In the course of the work carried out it may be necessary to remove the appliance from its operating position. Whilst all reasonable care will be taken, Baumatic Ltd cannot accept responsibility for damage sustained to any property whatsoever in this process.

This guarantee is in addition to and does not diminish your statutory or legal rights.

Contacting Baumatic Ltd

Sales	Service	Spares	Technical/Advice
TEL: 0118 933 6900	TEL: 0118 933 6911	TEL: 0118 933 6922	0118 933 6933
FAX: 0118 931 0035	FAX: 0118 986 9124	FAX: 0118 933 6942	0118 933 6942

For ROI (Republic of Ireland), please contact one of the numbers below:

TEL: 01 – 6266798 FAX: 01 - 6266634

Thanks you for buying Baumatic.

* Applies to UK, Scotland, Wales & Northern Ireland only (Republic of Ireland has 1 year labour & 1 year parts warranty only)

Baumatic Ltd

You will be mine

Headquarters

Baumatic Ltd.
Baumatic Buildings,
6 Bennet Road,
Reading,
Berkshire
RG2 0QX, United Kingdom

Sales Telephone
+44 118 933 6900

Sales Fax
+44 118 931 0035

Service Telephone
+44 118 933 6911

Service Fax
+44 118 986 9124

Spares Telephone
+44 118 933 6922

Technical / Advice Telephone
+44 118 933 6933

E-mail:

sales@baumatic.co.uk

technical@baumatic.co.uk

Http (Internet site):
www.baumatic.com

