

Installation control and protection

3.1 INTRODUCTION [13, 410, 421, 430]

Electrical installations must be protected from the effects of short circuit and overload. In addition, the people using the installations, as well as the buildings containing them, must be protected from the effects of electric shock, fire and of other hazards arising from faults or from misuse.

Not only must automatic fault protection of this kind be provided, but an installation must also have switching and isolation that can be used to control it in normal operation, in the event of emergency, and when maintenance is necessary. This Chapter will consider those Regulations that deal with the disconnection of circuits, by both manual and automatic means, the latter in the event of shock, short circuit or overload. It does not include the Regulations that concern automatic disconnection in the event of an earth fault: these are considered in {Chapter 5}.

In order that anyone operating or testing the installation has full information concerning it, a diagram or chart must be provided at the mains position showing the number of points and the size and type of cables for each circuit, the method of providing protection from normal conditions, (which was previously known as direct contact in the 16th Edition) (see {3.4.5}) and details of any circuit in which there is equipment, such as passive infra-red detectors, electronic fluorescent starters, or other devices that are vulnerable to the high voltage used for insulation testing.

3.2 SWITCHING

3.2.1 Switch positions [131, 530, 536 and 537]

A switch is defined as a device that is capable of making, carrying and breaking a circuit under normal and under overload conditions. It can make, but will not necessarily break, a short circuit, which should be broken by the overload protecting fuse or circuit breaker. A switching device may be marked with ON and OFF positions, or increasingly, the numbers 1 for ON and 0 for OFF are being used.

A semiconductor device is often used for switching lighting and heating circuits, but will not be suitable for disconnecting overloads; thus, it must be backed up by a mechanical switch. The semiconductor is a functional switch but must NOT be used as an isolator.

{Figure 3.1} shows which poles of the supply need to be broken by the controlling switches. For the TN-S system (earth terminal provided by the Electricity Company), the TN-C-S system (protective multiple earthing) and the TT system (no earth provided at the supply), all phase conductors MUST be switched, but NOT the protective (earth) conductor.

The neutral conductor need not be broken except for:

- 1 the main switch in a single-phase installation, *or*
- 2 heating appliances where the element can be touched, *or*
- 3 autotransformers (not exceeding 1.5 kV) feeding discharge lamps

The neutral will need to be disconnected for periodic testing, and provision must be made for this; it is important that the means of disconnection is accessible and can only be completed with the use of a tool. The protective conductor should never be switched, except when the supply can be taken from either of two sources with earth systems which must not be connected together. In this case the switches needed in the protective conductors must be linked to the phase switches so that it is impossible for the supply to be provided unless the earthing connection is present.

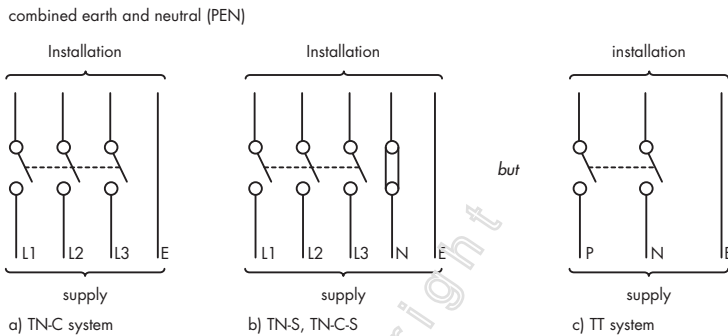

Fig 3.1 Supply system broken by switches
(a) TN-C system (b) TN-S, TN-C-S systems (c) TT systems

Every circuit must be provided with a switching system so that it can be interrupted on load. In practice, this does not mean a switch controlling each separate circuit; provided that loads are controlled by switches, a number of circuits may be under the overall control of one main switch. An example is the consumer's unit used in the typical house, where there is usually only one main switch to control all the circuits, which are provided with individual switches to operate separate lights, heaters, and so on. If an installation is supplied from more than one source there must be a separate main switch for each source, and each must be clearly marked to warn the person switching off the supplies that more than one switch needs to be operated.

It should be noted that a residual current device (RCD) may be used as a switch provided that its rated breaking current is high enough. It is of the utmost importance that all switches and isolators are clearly identified to indicate their functions. [Table 53] gives extensive guidance on the selection of protective, isolation and switching devices.

3.2.2 Emergency switching [537.4, 537.6]

Emergency switching is defined as rapidly cutting the supply to remove hazards. For example, if someone is in the process of receiving an electric shock, the first action of a rescuer should be to remove the supply by operating the emergency switch, which may well be the main switch. Such switching must be available for all installations. Note that if there is more than one source of supply a number of main

switches may need to be opened (see {3.2.1}). The designer must identify all possible dangers, including electric shock, mechanical movement, excessive heat or cold and radiation dangers, such as those from lasers or X-rays. Means of operation (handles, pushbuttons etc.) should be clearly identified, preferably by using the colour red.

In the special case of electric motors, the emergency switching must be adjacent to the motor. In practice, such switching may take the form of a starter fitted close to the motor, or an adjacent stop button (within 2 m) where the starter is remote. Where a starter or contactor is used as an emergency switch, a positive means must be employed to make sure that the installation is safe. For example, operation should be when the operating coil is de-energised, so that an open circuit in the coil or in its operating circuit will cause the system to be switched off {Fig 3.2}. This is often called the 'fail-safe' system.

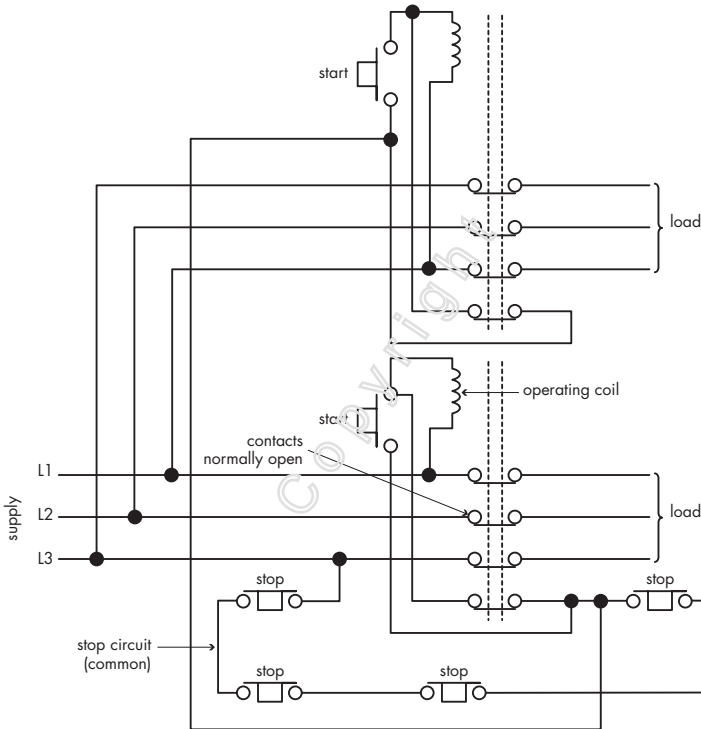

Fig 3.2 Two circuit breakers linked to a common stop circuit. The system is 'fail-safe'.

To prevent unexpected restarting of rotating machines, the 'latching off' stop button shown in {Fig 3.3} is sometimes used. On operation, the button locks (latches) in the off position until a positive action is taken to release it.

In single-phase systems, it must be remembered that the neutral is earthed. This means that if the stop buttons are connected directly to the neutral, a single earth fault on the stop button circuit would leave the operating coil permanently fed and prevent the safety system from being effective. It is thus essential for the operating coil to be directly connected to the neutral, and the stop buttons to the phase. Such an earth fault would then operate the protective device and make the system safe.

The means of emergency switching must be such that a single direct action is required to operate it. The switch must be readily accessible and clearly marked in a way that will be durable. Consideration must be given to the intended use of the premises in which the switch is installed to make sure as far as possible that the switching system is always easy to reach and to use. For example, the switch should not be situated at the back of a cupboard which, in use, is likely to be filled with materials making it impossible to reach the switch.

In cases where operation could cause danger to other people (an example is where lighting is switched off by operating the emergency switch), the switch must be available only for operation by skilled or instructed persons. Every fixed or stationary appliance must be provided with a means of switching which can be used in an emergency. If the device is supplied by an unswitched plug and socket, withdrawal of the plug is NOT acceptable to comply with this requirement; such action is acceptable for functional switching {3.2.4}.

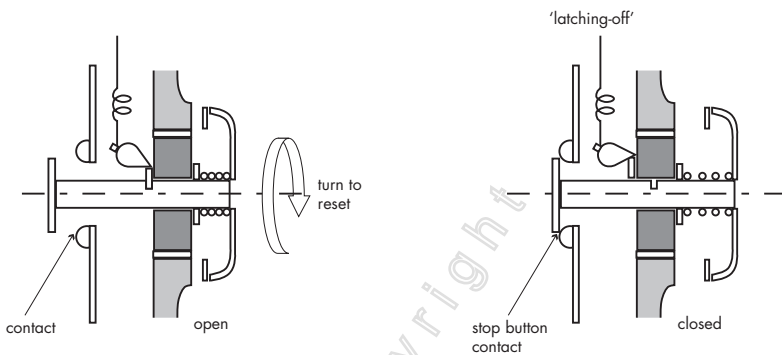

Fig 3.3 'Latching-off' stop button

Where any circuit operates at a p.d. (potential difference) exceeding low voltage a firefighter's switch must be provided. Such installations usually take the form of discharge lighting (neon signs), and this requirement applies for all external systems as well as internal signs that operate unattended. The purpose is to ensure the safety of fire fighters who may, if a higher voltage system is still energised, receive dangerous shocks when they play a water jet onto it. The firefighter's switch is not required for portable signs consuming 100 W or less which are supplied via an easily accessible plug and socket.

The firefighter's switch must meet the following requirements

- 1 The switch must be mounted in a conspicuous position not more than 2.75m from the ground.
- 2 It must be coloured red and have a label at least 150 mm x 100 mm in 36 point lettering reading 'FIREFIGHTER'S SWITCH'. On and off positions should be clearly marked, and the OFF position should be at the top. A lock or catch should be provided to prevent accidental reclosure.
- 3 For exterior installations the switch should be near the load, or to a notice in such a position to indicate clearly the position of the well-identified switch.
- 4 For interior installations, the switch should be at the main entrance to the building.
- 5 Ideally, no more than one internal and one external switch must be provided. Where more become necessary, each switch must be clearly marked to indi-

cate exactly which parts of the installation it controls.

- 6 Where the local fire authority has additional requirements, these must be followed.
- 7 The switch should be arranged on the supply side of the step-up sign transformer.

3.2.3 Switching for mechanical maintenance [537.3]

Mechanical maintenance is taken as meaning the replacement and repair of non-electrical parts of equipment, as well as the cleaning and replacement of lamps. Thus, we are considering the means of making safe electrical equipment which is to be worked on by non-electrical people.

Such switches must be:

- 1 easily and clearly identified by those who need to use them
- 2 arranged so that there can be no doubt when they are on or off
- 3 near the circuits or equipments they switch
- 4 able to switch off full load current for the circuit concerned
- 5 arranged so that it is impossible for them to be reclosed unintentionally.

Where mechanical maintenance requires access to the interior of equipment where live parts could be exposed, special means of isolation are essential. Lamps should be switched off before replacement.

3.2.4 Functional switching [537.5]

Functional switching is used in the normal operation of circuits to switch them on and off. A switch must be provided for each part of a circuit that may need to be controlled separately from other parts of the installation. Such switches are needed for equipment operation, and a group of circuits can sometimes be under the control of a single switch unless separate switches are required for reasons of safety. Semiconductor switches may control the current without opening the poles of the supply. Off-load isolators, fuses and links must not be used as a method of switching. A plug and socket may be used as a functional switching device provided its rating does not exceed 16 A. It will be appreciated that such a device must not be used for emergency switching (see {3.2.2}).

3.3 ISOLATION

3.3.1 Isolator definition [537.2]

An isolator is not the same as a switch. It should only be opened when **not** carrying current, and has the purpose of ensuring that a circuit cannot become live whilst it is out of service for maintenance or cleaning. The isolator must break all live supply conductors; thus both phase and neutral conductors must be isolated. It must, however, be remembered that switching off for mechanical maintenance (see {3.2.3}) is likely to be carried out by non-electrically skilled persons and that they may therefore unwisely use isolators as on-load switches. To prevent an isolator, which is part of a circuit where a circuit breaker is used for switching, from being used to break load current, it must be interlocked to ensure operation only after the circuit breaker is already open. In many cases an isolator can be used to make safe a particular piece of apparatus whilst those around it are still operating normally. Where the means of isolation is remote from the equipment it controls some form of locking should be used to ensure that the supply cannot be restored unexpectedly, for example when the equipment is being worked on; this is called *locking off*. Suitable devices may be