

Manual Fill 30L Stainless Steel Urn



Product Description

- Locking tap design - can easily switch from constant flow to controllable.
- Flush fit handle with fingertip guard - for extra safety against steam.
- Heating element fitted with thermal cut out - provides boil dry protection.
- Robust easy clean steel construction - ensures simple maintenance.
- CE marked and EMC Tested - for reassurance and peace of mind.
- Neon indicator light - shows when the unit is on and when the water is heating up to temperature.

Dimensions (mm)

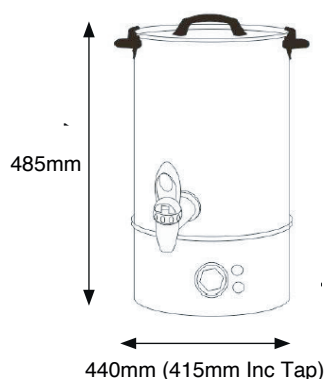

Product Code:	444448530
Model No.:	MFCT30ST
EAN Barcode:	5011832025975
Product Type:	Manual Fill Urn
Warranty Period:	12 Months

Technical Information

Product info:

Capacity (L) 30

Unit external width (mm) 440

Unit external depth (mm) 415

Unit external height (mm) 485

Packed width (mm) 400

Packed depth -Inc Tap (mm) 400

Packed height (mm) 540

Product weight (kg) 4.7

Packed weight (kg) 6.74

Material / Colour Stainless Steel

Heat up time (mins) 70

Tap Height to counter (mm) 130

Concealed element Yes

Variable thermostat Yes

Carry Handles Yes

Boil dry safety cut-out Yes

Power rating (kW) 2.5kW

Voltage supply (V) 220-240V / 50-60Hz

UK 3 pin plug Yes

Fitted cable length (m) 1.7

Energy consumption 1kW (per hour)

