

**WIRELESS WEATHER STATION  
C-8135  
USER'S INSTRUCTIONS**



<b>OVERVIEW.....</b>	<b>4</b>
<b>GETTING STARTED.....</b>	<b>7</b>
<b>WHERE TO PLACE THE APPLIANCE.....</b>	<b>9</b>
<b>DISPLAY OF TEMPERATURES MEASURED BY THE TRANSMITTER.....</b>	<b>11</b>
<b>MINIMUM AND MAXIMUM TEMPERATURES.....</b>	<b>13</b>
<b>RECEPTION OF TIME SIGNAL.....</b>	<b>14</b>
<b>SETTING TIME AND DATE MANUALLY.....</b>	<b>17</b>
<b>ALARM FUNCTION.....</b>	<b>19</b>
<b>BATTERY REPLACEMENT.....</b>	<b>22</b>
<b>CAUTION.....</b>	<b>23</b>
<b>DISTURBANCES AND REMEDY.....</b>	<b>24</b>

## **OTHER DISTURBANCES**

Press the RESET button of the transmitter first, then press the RESET button of the back of the receiver.

4. Is the alarm clock positioned too close to a TV set or a computer monitor? Try change to the location of the receiver .
5. Other radio-controlled appliances such as garage door openers, alarm systems or wireless headphones can also cause temporary reception disturbances. However, reception of temperature signals continues as soon as the disturbance is over.

#### **A NEW TRANSMITTER IS NOT RECEIVED**

Have you assigned a channel to the transmitter? (Each transmitter has to be assigned to a different channel, i.e. its own channel). Please refer to the chapter "Getting started" when necessary.

Press the RESET button in the battery compartment of the transmitter, by inserting a wire (for example a straightened paper clip) into the RESET-opening.

Place the transmitter as close as possible to the receiver, and proceed a re-setting RESET after the batteries have been inserted. This guarantees the exact synchronization of transmission and reception processes.

#### **FEATURES:**

- ◆ Year, month, date, day, hour, minute, second display
- ◆ 12/24 hour format
- ◆ Indoor / Outdoor Temperature
- ◆ Temperature alert
- ◆ Temperature tendency
- ◆ Max. / Min. temperature record

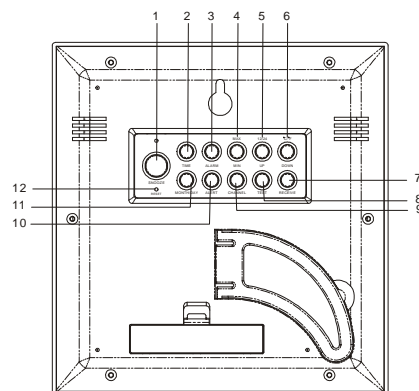
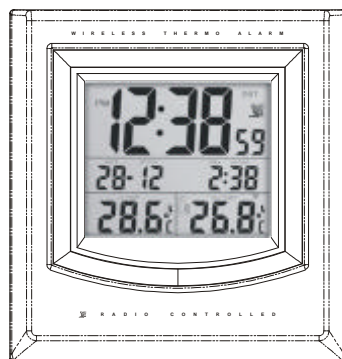

## **DISTURBANCES AND REMEDY**

### **THE TIME CANNOT BE RECEIVED**

Like all radio receivers, this clock is subject to certain reception restrictions and transmitter disturbances. Sources of interferences are for example thunderstorms, metallic structural elements in buildings, household appliances that are not freed, TV sets and personal computers. Furthermore, the time signal transmitter itself may but shut off temporarily. If the receiver does not receive the time, change its location.

### **THE TRANSMITTER IS NOT RECEIVED**

If the transmission of the measured outdoor temperatures fails without any explicable reason, --- appears in the display of the corresponding channel. Press TEST for about 2 seconds, to start signal search again. If this does not help, check the following:

1. Are the batteries of the clock ok?
2. Is the corresponding transmitter installed within the possible range of transmission (max. up to 30m)?
3. At temperatures below the freezing point, the output of the batteries and therefore the range of the transmitter may decrease considerably. As temperature rise again, the normal battery power is resumed.

### **CAUTION**

Protect the clock and the transmitter from dust, impacts, extreme temperature variations and direct sunlight, wipe the dust off with a dry cloth.

The clock must not be exposed to humidity.

The transmitter is protected against humidity. If you place it outdoors, choose a protected place, so that the transmitter is not exposed to rain directly or direct sunlight.

### **OVERVIEW**

1. SNOOZE key: Switch snooze
2. TIME key: Time setting
3. ALARM key: Switch alarm On / Off
4. MAX / MIN key: Display max. / min. temperature
5. 12/24 / Up key: Selecting time format / increase value
6. °C / °F / Down key: Selecting temperature unit / decrease value
7. RECEIVE key: Starting reception of time signal
8. TEST key: Starting reception of temperature
9. CHANNEL key: Selecting channel for transmitter
10. ALERT key: Temperature alarm
11. MONTH / DAY key: Month / Date setting
12. RESET key: Reset the all data

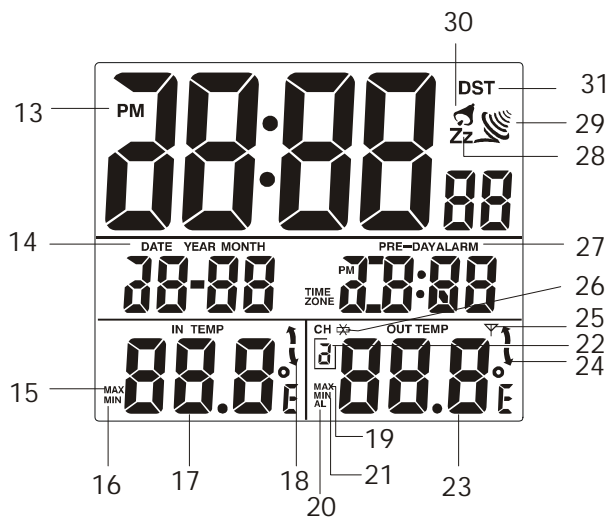

## **BATTERY REPLACEMENT**

When the LCD becomes dim, the battery of the receiver have to be replaced. If the symbol  appears next to the outdoor temperature, the batteries of the then displayed transmitter have to be replaced by new ones immediately. Use 2 micro batteries for the receiver and 3 mignon batteries for the receiver, preferably alkaline.

### **Note:**

1. All settings are cleared on replacing the batteries.
2. Press the TEST button for 2 seconds after changing batteries, to start communication between receiver and transmitter again.
3. Attention should be drawn to the environment aspects of battery disposal 

**Note:**

- The alarm temperature can be chosen within a range of -30°C to 60°C.
- The upper limit must not be set lower than the lower limit.
- The temperature alarm function can only be activated if the alarm function is switched on, too.

By pressing ALERT briefly, the temperature alarm time and the set max. temperature are displayed. Press ALERT again to display the set min. temperature.

**SWITCHING ON/OFF TEMPERATURE ALARM**

1. Press ALERT briefly in the normal display mode. The temperature alarm time and the set maximum temperature are displayed.
2. Press the ALARM button, the temperature alarm can be switched on (AL is displayed next to the outdoor temperature) and off (AL disappears).

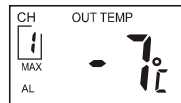

AL ON

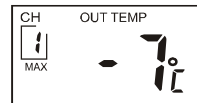

AL OFF

13. Time
14. Date / Month, Year
15. Indoor Max. temperature
16. Indoor Min. temperature
17. Indoor temperature
18. Indoor temperature tendency
19. Max. outdoor temperature
20. Temperature alarm function is activated
21. Min. outdoor temperature
22. Channel of transmitter
23. Outdoor temperature
24. Outdoor temperature tendency
25. Reception of signals from transmitter
26. Low battery indicator of transmitter
27. Temperature pre-alarm time / weekday
28. Snooze function is activated
29. Radio controlled reception signal
30. Alarm
31. DST (Daylight Savings Time)

## **GETTING STARTED**

The wireless weather station can receive signals from up to 3 transmitters.

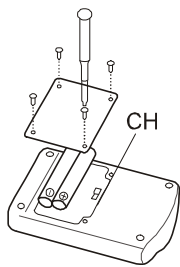

1. Unscrew the four screws of the battery compartment cover on the back of the transmitter and lift the cover off.
2. Set the channel CH. If you use several transmitters, each one has to be assigned to a different channel.
3. Insert two AAA batteries in the compartment. Be sure to insert them in the right way round (+/-)
4. Put the cover on and tighten the screws

5. Open the battery door on the back of the receiver, insert 3 AA size battery as per the indication marked in the battery compartment.
6. Close the compartment.

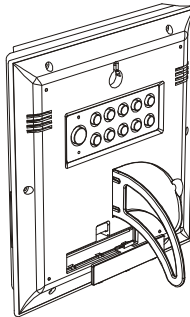

## **SETTING TEMPERATURE ALARM**

Use this function to be woken up at a determined period of time earlier, if the outdoor temperature falls below or rises above a certain temperature.

1. Keep the ALERT button pressed for 2 seconds. The temperature alarm time flashes.
2. Adjust the pre-alarm time with the UP and DOWN buttons. The time can be selected in 1-minute steps from 15 to 120 minutes.
3. Press the ALERT button briefly, the MAX outdoor temperature flashing.
4. Adjust the upper limit with UP and DOWN buttons.
5. Press the ALERT button again, the MIN outdoor temperature flashing.
6. Adjust the lower limit with the UP and DOWN buttons.
7. Press the ALERT button again (or wait for 30 seconds) to store the entered temperature alarm time and the min. & max. data.





## **ALARM FUNCTION**

### **SETTING ALARM TIME**

1. Keep the ALARM button pressed for 2 seconds. The alarm hour flashes.
2. Adjust the hour with the UP and DOWN buttons.
3. Repeat the above operation to adjust the alarm minutes.
4. Press ALARM again to store the entered alarm time.

### **TURN ALARM ON/OFF**

1. In alarm mode, press the ALARM button,  appears in the upper line of the LCD. Press the ALARM button again, Zz appears.
2. To switch the alarm off, press ALARM button until the  and Zz disappear.

### **Note:**

At the set alarm time, an alarm signal sounds for 120 seconds, which accelerates in five levels (crescendo alarm). If the snooze function is activated, the alarm will sound again up to 4 times in 5-minutes intervals.

**Note:** Don't mix old and new batteries, do not use different types of battery in one unit.

After the batteries are inserted, the current temperature is displayed and the radio controlled function activates (the reception symbol  flashes in the display). If this is not the case, press the RESET button with a pin.

After 2-10 minutes the current time and date are set. If this is not the case, read the chapter "DISTURBANCES AND REMEDY" or adjust the clock manually.

The receiver searches automatically all three channels for transmitter signals. If signal is received,  briefly appears and the temperature is displayed. If several transmitters are in use, press CHANNEL button to display the temperatures from different transmitter. If no signals are received, --- appears in the LCD. If necessary, read the chapter "Disturbances and remedy".

The transmitter checks the temperature about once per minute and sends it to the receiver. If the temperature changes by more than 0.4°C, the change is transmitted immediately and the display is updated.

### **WHERE TO PLACE THE APPLIANCE**

Place the receiver and transmitter within the effective range of 30 meters approx. Do not position the transmitter in direct proximity of a floor or ceiling, as this limits the range of reception. The range of reception is also determined by the materials in buildings. Try out where your receiver receives the signals best.



To put up the transmitter, unfold the clip of the holder and insert the transmitter into the holder.

### **SETTING THE DATE**

1. Keep the MONTH/DAY button for 3 seconds, the year flashes.
2. Adjust the year with UP or DOWN buttons.
3. Repeat the above operation to set the MONTH and DATE
4. Press MONTH/DAY again to store the entered date.

Once the year, month and date are set, the weekday is set automatically.

## **SETTING TIME AND DATE MANUALLY**

If the clock cannot receive the time signal successfully, you can set the time and date manually.

1. Keep the TIME button pressed for 3 seconds, it flashes in the hour display.
2. Adjust the hour with the UP and DOWN buttons. If you keep the button pressed, the time is advanced fast until you let go of the button.
3. Repeat the above operation to set the minute.
4. Press TIME button again, seconds flashes, set the seconds to 00 with UP button.
5. Press TIME button to store the set values.

## **SETTING THE TIME FORMAT**

The 12/24 button allows you to select the 12-hour format and the 24-hour format.

The holder can also be fastened to a wall, with the eyelet and the fastening materials provided.

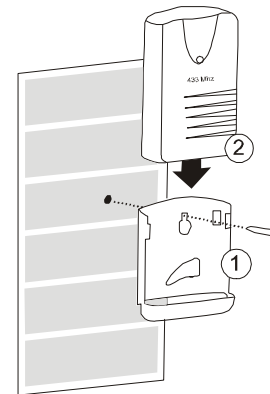

Choose a place that is not exposed to direct sunlight. If you want to place the transmitter outdoors, choose a protected place, where it is not exposed to rain: it should be placed as high up from the ground or far away from damp or metallic surfaces as possible.

## **DISPLAY OF TEMPERATURES MEASURED BY THE TRANSMITTER**

The receiver searches automatically all three channels for signals. If signals are received, the temperature appears in the lower line of the LCD.

Press CHANNEL as often as necessary, until the channel number of the corresponding transmitter appears in the LCD.

The receiver updates the temperature value about once per minute according to the data sent by the transmitter. If no signals are received or the transmission is interfered with, --- appears in the display. In this case, press the TEST button for about 3 seconds to start search anew to synchronise transmission and reception intervals again. During the search process, the display for the channel flashes in the LCD.

If this still does not help, change the location of the receiver or the transmitter.

You can select the temperature display between Celsius and Fahrenheit by pressing the °C/°F button in normal mode.

## **STARTING THE TIME SIGNAL RECEPTION MANUALLY**

If no reception display is shown, time signal reception can be activated manually.

1. Press the RECEIVE button, the reception display flashes. If no signal is received, the reception will stop after 6-12 minutes automatically.
2. Press the RECEIVE button again, until a time signal is received successfully.

### **Note:**

Do not use the manual reception too often, as it leads to a higher power consumption and consequently reduces the lifespan of the batteries.



## **MINIMUM AND MAXIMUM TEMPERATURES**

The min. and max. temperatures measured by each transmitter as well as by the receiver itself are stored separately.

### **CALLING UP**

Press the MAX/MIN button once to display the stored max. temperature, press it twice to display the stored min. temperature. At the same time the indications "MAX" or "MIN" appear at the left of the temperature display. Press MAX/MIN button again, the current temperatures are displayed again. If several transmitters are used, press the CHANNEL button as often as necessary, until the temperature of the desired transmitter is displayed.

### **DELETING**

To delete the stored min. and max. temperatures, keep the MAX/MIN button pressing for about two seconds until a short signal sounds.

## **RECEPTION OF TIME SIGNAL**

The receiver receives the time signals via a built-in antenna and adjusts automatically. After setting the time, the clock works with an internal quartz controlled mechanism.

Several times per day the receiver switches on and compares the transmitted time displayed. The internal quartz movement itself is highly accurate, thus it does not matter if occasionally the time signal is not received.

For a good reception of time signals, the receiver should not be placed near metallic objects or electric appliances, to avoid interferences.

When used for the first time (after inserting the batteries or pressing RESET), the appliance starts receiving time signals and the reception display flashes.

After the reception of time signals, the reception display is shown constantly and indicates the quality of the previous time signal in three types: