

CONTACTUM

Connect & Protect

DEFENDER 2.0 CONSUMER UNIT INSTALLATION INSTRUCTIONS

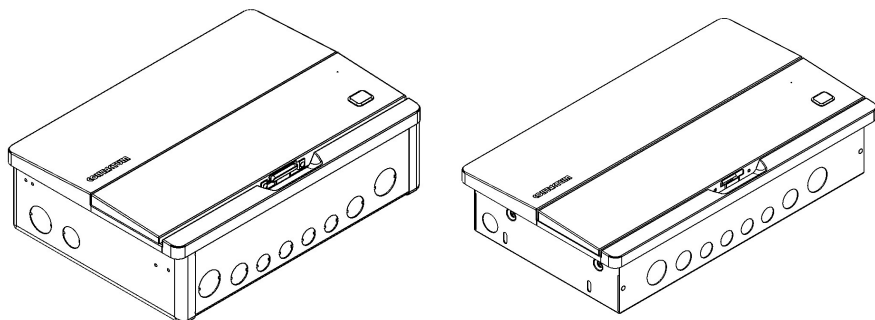

Introduction

These instructions are intended for use by qualified electricians. This unit must be installed by a qualified registered electrician in accordance with the current edition of the IET Regulations for Electrical Installations (BS7671 Requirements for Electrical Installations).

Your Contactum Defender Consumer unit consists of a non-combustible enclosure which includes a top hat mounting din rail onto which an isolator and/or RCD is mounted together with the MCBs or RCBO's. Neutral and earth terminal bars are included as well as all connecting cables (cable numbers vary depending on board configuration).

Contactum Defender has been tested by an independent and qualified third party laboratory. Those tests will guarantee the performance and the safety requirements of MCB and RCBO devices installed in the Defender consumer unit according to the BS EN 61439-3 standard

In the case of the split load and dual split units both the isolator and RCD's have been fitted onto the din rail. The neutral connector and the leads connecting the isolator to the RCD and the RCD to the neutral terminals are also fitted. Busbars are provided loose to enable them to be cut for any split load configuration.

Tools

Torque screwdriver Combi or Flat, Pliers, Cutters, Hammer, Punch & Hacksaw.

DO NOT USE POWER TOOL SCREWDRIVERS ON ELECTRICAL CONNECTIONS

Cleaning

Use a soft damp cloth with lukewarm water (Only clean outside of unit)

Important Notes:

1. The rated current of the upstream OCPD shall not exceed the rated InA of the consumer unit which is indicated on the product label inside the board.
2. After completing the assembly please ensure the correct tightness of all screws (follow the Torque settings label inside the enclosure).
3. All components used in Contactum consumer units must be supplied or approved by Contactum. The use of any other components within the Contactum consumer unit, whether complying with the relevant standard or not, will negate the Contactum guarantee.

Defender 2.0 Consumer Units

Surface Mounted Defender

1. Remove front cover by opening lid and unscrewing the two fixing screws.

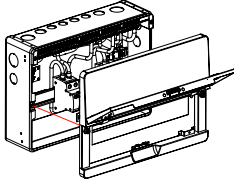

2. Remove appropriate knockouts from top, bottom, sides and back of the enclosure base.

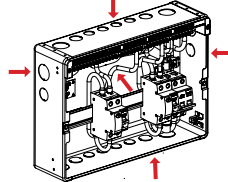

3. Fix Base to wall using screws and wall plugs as appropriate, use keyhole slots to hang in position and ensure level (Integrated spirit level) and other fixing holes to secure firmly. Bring cables through appropriate apertures ensuring the cables installation entry method shall, as far as is reasonably practicable, maintain the fire containment of the enclosure.

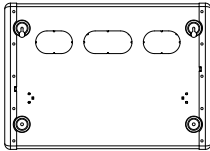

4. To finish the installation follow the common steps.

Flush Mounted Defender

1. Remove front cover and internal chassis by opening lid and unscrewing the two fixing screws.

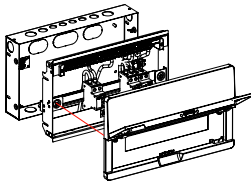

2. Remove appropriate knockouts from top, bottom, sides and back of the enclosure base.

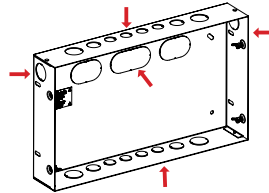

3. Fix base to stud work using screws and wall plugs as appropriate, ensure level and use highlighted slots to secure firmly. Bring cables through appropriate apertures ensuring the cables installation entry method shall, as far as is reasonably practicable, maintain the fire containment of the enclosure.

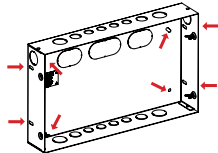

4. Insert the internal chassis into the base until the upper and lower lips of the chassis are flush with the wall, tighten the wing nuts (2 nuts on either side).

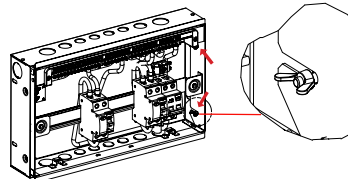

5. To finish the installation follow the common steps.

Interface Characteristics

Standard	BS EN 61439-3
Max Operating Voltage (Ue)	230V
Rated insulation Voltage (Ui)	400V
Rated Conditional Short Circuit Current (Icc)	16kA
Rated impulse withstand voltage (Uimp)	4kV
Rated Current (InA)	Up to 100A (Except 4 Module Defender is 63A)
Operating Frequency	50Hz
IK rating	IK05
IP rating	IP4X on top and IP2XC on sides and bottom
Rated current of outgoing circuits (Inc)	MCB: 6A-63A RCBO: 6A-50A RCD: 63A and 100A Type A
Rated Diversity Factor (RFD) Values of assumed loading in BS EN 61439-3	2-3 Way: 0.8 4-5 Way: 0.7 6-9 Way: 0.6 10 Way and above: 0.5
Pollution Degree	2
Usage	Domestic, Indoor use only
Board Type	DBO (Distribution Board for Use by Ordinary Persons)

CONTACTUM

Contactum Ltd, Victoria House,
2 Blackmoor Lane,
Croxley Green Business Park,
Watford WD18 8GA
T: 020 8208 7419
E: sales@contactum.co.uk
www.contactum.co.uk

