

Dimplex

SERVICE POLICY/GUARANTEE

 Dimplex[®]
aquabatix
ELECTRIC SHOWERS

In the event of you needing to contact the Dimplex Customer Service Department, the following procedure should be followed:-

- 1** Before telephoning the Dimplex Customer Service Department you should ensure that you have the model number, power rating, serial number and date of purchase.
- 2** The Dimplex Customer Service Department will be able to inform you whether the fault can be rectified by the provision of a replacement part or an on site visit by a Qualified Service Engineer.
- 3** If a service call is booked, you or a representative must be present during the Engineers visit.
- 4** A charge will be made where a call under the terms of the guarantee has been booked and a failure was not product related, or an engineer arrives and is not able to gain access.
- 5** If the product is no longer covered by the Guarantee, a charge will be made for the site visit and for any parts supplied.

Customer Services Tel 0870 240 9402

GUARANTEE

Glen Dimplex Limited guarantee this product for a period of two years, from date of purchase, against mechanical and electrical defects arising from faulty materials or manufacturing defects, providing the product has been installed by a competent person in accordance with the fitting instructions.

Glen Dimplex Limited undertake to repair or replace, at their discretion, without charge, provided the product has been properly maintained and operated in accordance with the operating instructions. Any component found to be defective during this period, as the result of misuse or damage, or the effects of scaling, will not be covered by this guarantee.

This product must not be modified, repaired or taken apart except by a person authorised by Glen Dimplex Limited.

This Guarantee is only valid within the United Kingdom and does not cover product used commercially.

This Guarantee does not affect your statutory rights.

Glen Dimplex UK Limited, Millbrook House, Grange Drive, Hedge End, Southampton SO30 2DF.
Tel 0870 077 7117 Fax 0870 727 0109



ax³

Shower User Guide

DIMENSIONS

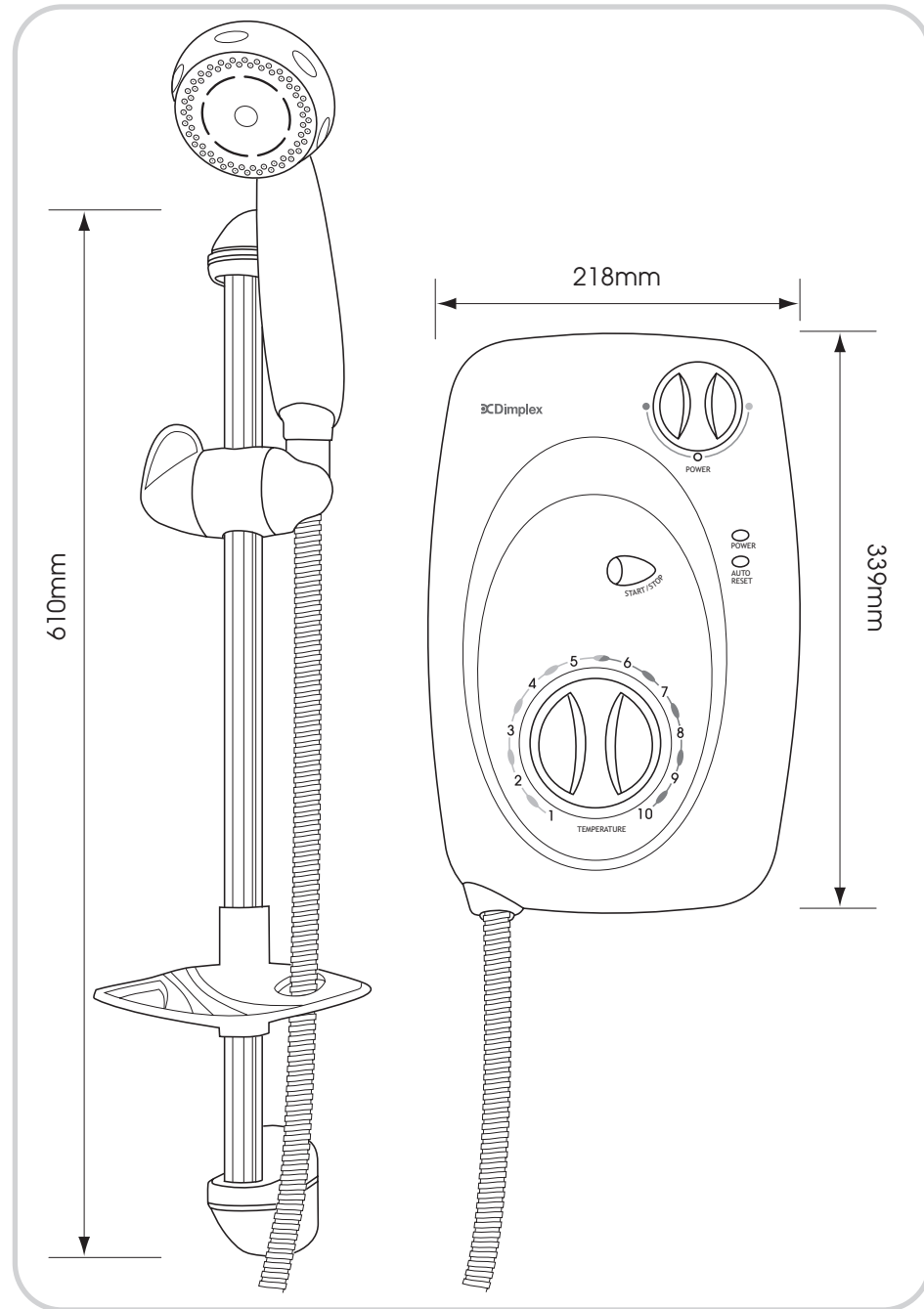

2

UNPACKING AND IMPORTANT NOTICES / INSTALLATION

SECTION 1
Unpacking and important notices

Contents

- 1 x Shower Unit
- 1 x Showerhead
- 1 x Flexible Hose
- 1 x Slider Rail Tube
- 1 x Slider Rail Brackets
- 1 x Height adjuster
- 1 x Screw pack
- 1 x Soap dish
- 1 x Showerhead key

IMPORTANT NOTICES
PLEASE READ BEFORE ATTEMPTING TO INSTALL THE SHOWER UNIT

- 1) The shower unit must be installed by a suitably qualified person and conform to IEE Regulations and National Water Council Bylaws.
- 2) The shower must only be connected to a 15mm mains cold water supply.
Do not connect the unit to the cold water supply of a header tank.
- 3) The minimum recommended running water pressure to which the shower heater may be connected is 15lb/sq in (1bar); running pressure of 8 litres/minute; maximum static pressure recommended 150lb/sq in (10 bar).
- 4) The shower unit must not be fitted where it may be exposed to frost, for example in an outdoor shower area. **The shower must not be used if suspected of being frozen.** Please note: Frost damage is not covered by the guarantee.

- 5) **Do not use Plumbers jointing compound.** Use of plumbers jointing compounds invalidates the guarantee.

Complete all plumbing connections before making any electrical connections.

The outlet of the shower unit must only be connected to the hose and showerhead supplied with the unit. Use of other components will invalidate the warranty.

Always switch off at the isolating switch when the shower is not in use.

To comply with National Water Council bylaws a double check valve must be fitted where it is possible that the showerhead may come into contact with used water e.g. in the shower tray or bath.

Do not operate power tools in a wet environment. It is recommended that any power tools operated in the bath or shower area are supplied via a Residual Current Device (RCD).
WARNING! THIS APPLIANCE MUST BE EARTHED. This shower is for connection to a 230V-240V/50Hz mains electricity supply.

SECTION 2
Installation

Typical instantaneous electric shower installation

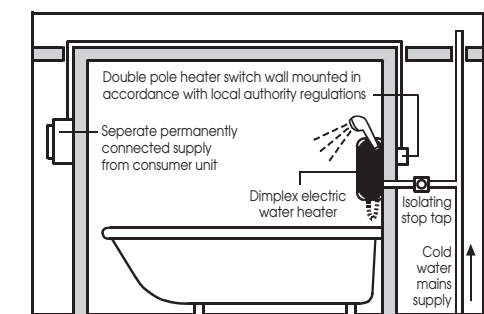

3

Planning the installation

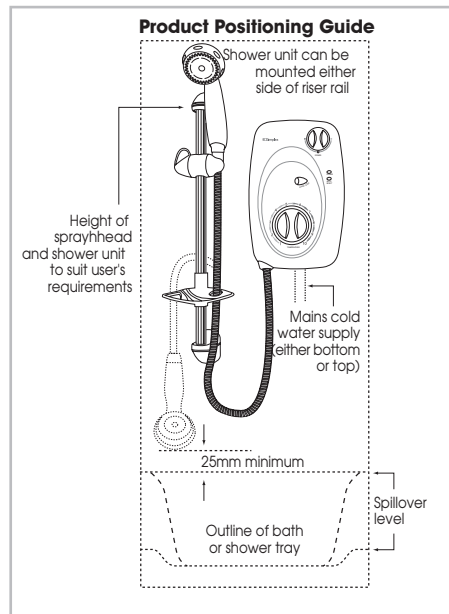

The shower should be located in a position where walls are protected from water and sufficient drainage is provided.

- 1) Consideration should be given to the location of the nearest cold mains water supply and the routing of this to the shower. The shower will accept a mains supply from the bottom, back or top of the unit. Remove the appropriate plastic plate from the back plate before commencing installation.
- 2) Avoid connecting the shower unit where it will be affected by water drawn off by other appliances, e.g. from the mains feed to the W.C. This may cause a drop in pressure too low for the shower unit to work correctly.

General

- 1) Fit an isolating valve to the mains water supply so that the shower can be serviced.
- 2) The shower unit is best placed to the right hand side of the riser rail and placed so that the top of the unit sits alongside the middle to top of the riser rail. This reduces the amount of water falling on the unit.

The top of the riser rail should be sited to coincide with the height of the tallest person using the shower.

Before drilling any holes check that there are no hidden cables or pipes below the surface to be drilled.

To avoid loss of small parts cover any drainage holes.

- 3) The shower unit should be positioned so that the showerhead cannot be immersed in the bath or shower tray when hanging down.

Where holes are to be drilled into a tiled surface a suitable tile or glass drill bit should be used to make a hole through the tile only. The hole made through the tile should be 0.5mm larger than the hole in the wall.

These installation instructions assume mounting onto a solid masonry wall. For other types of structure please amend the procedure accordingly.

Plumbing

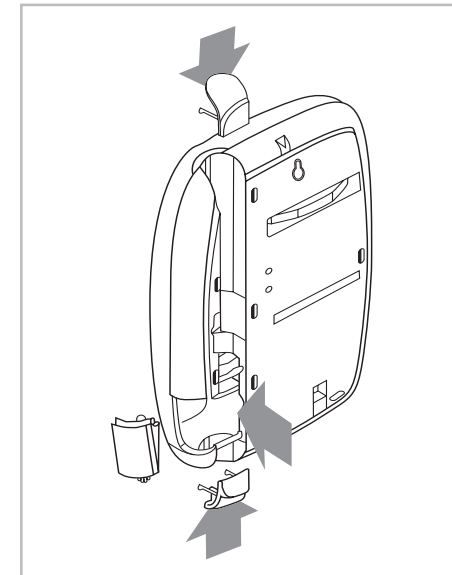

- 1) Remove the front cover of the shower unit complete with the two control knobs by removing the two screws securing it to the back plate. Remove the 'trim plate' at the bottom right-hand side of unit to allow easy access for the plumbing work.
- 2) Position the shower unit on the wall in the desired place and mark the location of the fixing holes.
- 3) Determine the direction of the inlet water supply: **bottom** (rising), **top** (falling) or **back** inlet. The shower unit is supplied with a swivelling push-fit inlet elbow. This elbow should be rotated to match the desired direction of water supply entry to the unit. Carefully remove the appropriate plastic break-out from the unit's back plate so that the mains water supply pipe can be routed into the unit.

- 4) Carefully drill the holes using a 5.5mm masonry drill (note when drilling through tiles first use a glass or tile drill bit of 6mm diameter to drill a hole through the tile).
- 5) Insert the plugs provided through the hole in the tile and fix the unit to the wall using the screws supplied. Do not tighten the screws fully at this stage.
- 6) Turn off the water supply at the isolating stop tap.
- 7) Bring the mains water supply using 15mm copper or stainless steel pipe to the shower unit so that it enters through the hole in the back plate.

- 8) Before connecting the shower unit, flush out any debris in the new pipework by connecting a hose to the end of the mains supply pipe and running the mains water until all the debris has cleared.

- 9) After flushing out, turn off the water supply and connect the pipe to the shower inlet. Having inserted the inlet pipe into the elbow, secure the joint by finger tightening the locking device, rotating in a clockwise direction.

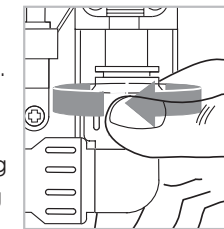

- 10) Make sure that the shower unit is positioned squarely on the wall and tighten the fixing screws. Tighten all plumbing joints and turn on the water supply to check for leaks. With the unit firmly fixed to the wall and the pipework free from leaks, dry the shower area in preparation for the electrical installation.

INSTALLATION

INSTALLATION / FINAL ASSEMBLY AND COMMISSIONING

Assembly

1 Part the mounting bracket assembly so that the fixing plate is separate from the cover. Establish the best position for the riser rail, and mark the wall for the lower mounting bracket. Make allowances for the tallest person likely to use the shower regularly.

2 When drilling through tiles use a suitable glass or tile drill of 6mm diameter to drill through the tile only. Use a no 10/5.5mm masonry drill to make a hole 35mm deep, and fit the wall plug. (NB some wall constructions may require the use of different types of wall fixings to those supplied). Screw the lower bracket base to the wall.

3 Locate the crimped end of the riser rail (Figure 4) into the mounting bracket, then fit the upper bracket to the rail. Ensure the rail is vertical, then mark the wall for the fixing.

4 NOTE If it is necessary to shorten the rail, use a junior hacksaw to cut the excess material from the plain end of the rail (the uncrimped end).

5 Insert the end pieces of the height adjuster into the body section matching the letters A and B (moulded into the ends of each piece) and twist so the pieces lock together.

6 With the shower head holder in the upright position (widest opening at the top) and the lever in the open position, slide the assembly onto the rail. Tighten the height adjuster to the rail by twisting the lever.

6

7 Insert the rail into the bottom and top brackets and screw the upper mounting bracket in place. Clip the end caps onto the mounting brackets.

Electrical

Switch off the water supply at the isolating valve before connecting the wiring to the unit.

The shower unit must be permanently connected to the electricity supply, direct from the consumer unit via a double pole linked switch with a minimum contact gap of 3mm.

It is recommended that the switch be a cord operated type with neon on/off indicator, otherwise the switch should be readily accessible, clearly identifiable and out of reach of any person using the shower. The wiring to the switch must be done without the use of a plug or socket outlet.

The cable used must be of a diameter suitable for the power rating of the shower selected. The table below may be used as a guide to the cable requirements. If in doubt consult a qualified electrician.

kW rating Isolating	Minimum switch (Amps)	Fuse rating (Amps)	Max cable length Consumer unit to shower (m)	
			6mm cable	10mm cable
7.5	40	40	27	44
8.5	40	40	23	38
9.5	40	40	21	32
10.5	45	45	18	30

The cable should be routed to the shower unit from either the top, bottom or back of the shower unit. This cable should be hidden from view.

Connect the **brown** live wire to the terminal marked **L**

Connect the **blue** neutral wire to the terminal marked **N**

Connect the **yellow** and **green** earth wire to the terminal marked **E** on the backplate.

IMPORTANT – ensure the terminal block screws are fully tightened and that no insulation enters the terminal block, preventing a good electrical connection.

To conform to IEE regulations the earth continuity conductor of the electrical installation must be effectively connected to all exposed metal parts of other appliances and services in the room in which the shower unit is installed.

WARNING! Do not attempt to operate the shower unit until the installation is fully complete.

SECTION 3
Final assembly and commissioning

With the unit wired and plumbed correctly the front cover may now be refitted.

1) Place the cover lightly over the shower unit and turn the knobs so that they engage correctly with the spindles. The front cover may then be pressed lightly into place and secured using the two fixing screws.

2) Fit the flexible hose to the shower unit and remove the showerhead.

3) Ensure that the power selector knob is in the cold position (solid blue) and the electricity supply is switched off at the isolating switch.

4) Turn the temperature control knob at the bottom of the unit fully anti-clockwise.

5) Turn on the power at the isolating switch.

6) Start the shower by pressing the Start/Stop button. The water should now begin to flow through the shower.

Warning do not attempt to turn the power knob to any other setting other than Cold at this stage.

7) Once a steady stream of water is achieved from the outlet of the shower unit stop the shower by pressing the stop/start button.

8) Pass the hose through the hole in the soap dish and refit the shower head.

9) Fit the handset into the height adjuster and clip the soap dish onto the riser rail.

The unit is now ready for commissioning.

Commissioning the shower

Important: The shower unit must be full of water before power (heat) settings are used.

7

- 1) Make sure that the power selector at the top of the shower is in the cold position and that the electrical supply has been isolated at the double pole isolating switch.
- 2) With the water supply to the unit turned on, turn the bottom temperature control knob anti-clockwise to the full cold position. No water should exit the shower either from the handset or from any other part of the shower unit.
- 3) Switch on the electrical supply at the double pole isolating switch, the power neon on this switch should light.
- 4) Turn the top power selector knob to the **'Cold'** setting (Solid Blue Symbol).
- 5) Start the shower by pressing the start/stop button. Water should start to flow from the handset within a few seconds.
- 6) Check that water flows freely from the shower within a few seconds. The water from the showerhead will be at full force and at a cool temperature.
- 7) Now turn the top power selector knob to the **'Low'** setting (Outline Red Symbol). Allow a few seconds for the warmer temperature to reach the showerhead – this shows that the **'Low'** power is operating correctly.
- 8) Now turn the top power selector knob to the **'High'** setting (Solid Red Symbol). The temperature at the showerhead will rise further – this shows that the full power setting is operating correctly.

- 9) Turn the bottom temperature control knob clockwise for hotter water and anti-clockwise for cooler water. Allow a few seconds between selections for the temperature change to reach the showerhead. Note that selecting a hotter setting in the temperature control reduces the flow of water.
- 10) Press the Stop/Start button to stop water flow.

A small amount of water may continue to drip from the unit as water drains from the pipe-work. This should stop within a few minutes.

The commissioning procedure is now complete.

SECTION 4 Operation

'Power indicator':

The power indicator on the shower unit will light when the shower is switched on and water is flowing on one of the two heat settings. The indicator does not light on the cold setting.

'Auto Reset Indicator'

The Auto Reset Indicator will illuminate if an overheat temperature is sensed during operation. Once activated the electricity supply to the elements is switched off until the unit has cooled sufficiently, where upon power to the elements will be restored.

Once the indicator has lit, allow the cold water to flow through the unit so that normal operation can resume as quickly as possible. At the next convenient time the shower head should be cleaned to remove any particles or limescale

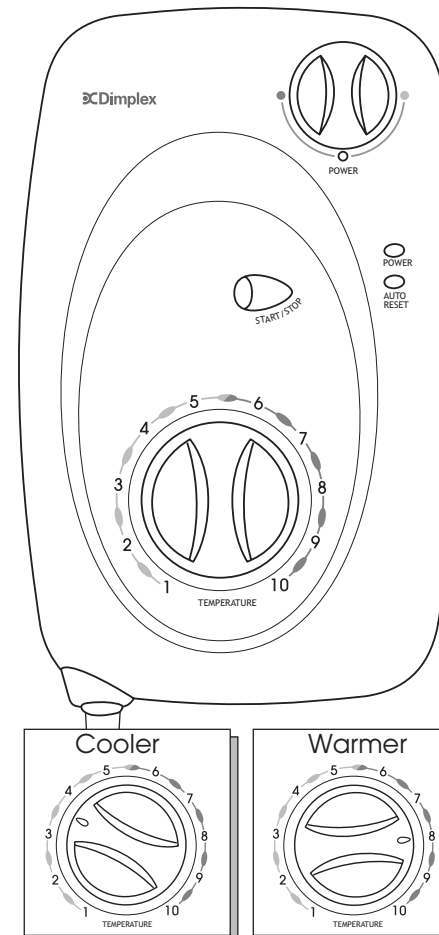
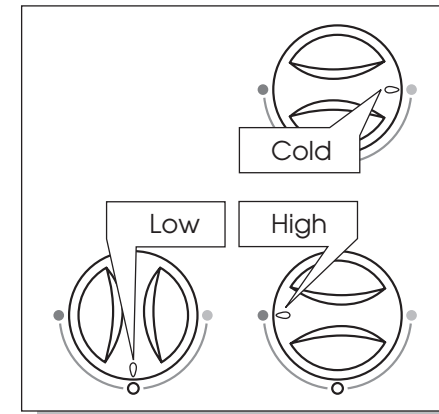

blocking the holes – see Section 5 'Looking after your shower'.

- 1) Switch on using the pull-cord or wall mounted switch.
- 2) To start the shower press the start/stop button, upon which water will start to run through the shower.
- 3) Select your power setting using the top control. The shower has three positions **'Cold'**, **'Low'** power and **'High'** power.

'Cold' setting (Solid Blue Symbol):

Adjustment of the flow control on this setting will only alter the flow of water not the temperature.

'Low' setting (Outline Red Symbol):

This is the low power setting for economy during warmer months or when a cool shower is required.

'High' setting (Solid Red Symbol):

This is the full power setting.

- 4) If necessary turn the bottom **'temperature'** control knob slowly to obtain the desired showering temperature. Waiting a few seconds after each adjustment for the temperature to stabilise.

To increase the shower temperature

turn the temperature control knob clockwise, this will decrease the flow of water and increase the shower temperature.

To decrease the shower temperature

turn the temperature control knob anti-clockwise, this will increase the flow of water and decrease the shower temperature.

- 5) To stop the shower press the stop/start button.
- 6) Switch off the electricity supply using the pull-cord or wall mounted switch.

SECTION 5
Looking after your shower

The showerhead should be cleaned periodically to remove limescale or other particles which will reduce the performance of the shower. The frequency of cleaning will vary according to the local water quality. In hard water areas cleaning will be needed more often than in soft water areas. A liquid non-abrasive bathroom cleaner may be used on external surfaces of the handset.

Rub-clean showerheads may be rubbed lightly to remove scale as required. Over time build-up of limescale requires the showerhead to be cleaned more thoroughly, as follows.

- 1) Use a liquid non-abrasive bathroom cleaner on external surfaces of the handset.
- 2) Engage the key into the spray cartridge recesses and turn anti-clockwise to unscrew.
- 3) Remove the two small black 'O' rings from the rear of the spray cartridge, and rinse the 'O' rings clean.
- 4) Brush the spray plate with a stiff bristled brush, if necessary immerse and soak the spray plate for several hours in a proprietary limescale remover. Rinse off all traces of limescale and limescale remover from the showerhead.

- 5) Replace the two black 'O' rings on the rear of the spray cartridge and refit the cartridge to the showerhead tightening with the key.'

SECTION 6
Trouble shooting

Before calling our customer service department please use the table to determine likely causes of the problem:

NOTE Under normal operation the shower heats the water as it passes through the unit. The temperature of the water is affected by the temperature of the water in the mains cold water supply and the speed with which the water flows through the unit. It is therefore normal for the water coming out of the shower to change temperature through summer and winter months where the mains water temperature changes. It is also normal for the water temperature to vary when other water appliances are being use in the home as these vary the water flow to the shower unit. Do not under any circumstances cover the showerhead or prevent or restrict water leaving the showerhead or unit. It is important to keep the showerhead clean, removing all lime scale and any other dirt blocking the holes of the showerhead. The showerhead must be cleaned as described in section 5 'looking after your shower'.

SECTION 7
Maintenance

Disconnect from mains electricity supply before removing front cover. All maintenance should only be carried out by a qualified service engineer.

SYMPTOM	POSSIBLE CAUSE	ACTION
No hot water	Power setting is at Cold.	Turn Power knob to a heat setting
	Low Water Pressure.	The water supply has dropped below the minimum operating pressure. Switch off other cold water devices and retry.
	The thermal cut-out has operated.	Turn the power knob to cold. Switch off the shower. Clean the showerhead, and restart the shower. Select a heat setting, if no hot water is produced call the Dimplex Service Centre.
Power indicator is not lit	The power setting is on cold.	Turn the power setting to a heat setting and the indicator should light.
	Water pressure below minimum required.	Check if water mains stop valve is fully open.
Water too hot	Not enough water flowing through the shower.	Increase flow rate via temperature control.
	Blockage in supply.	Blocked spray head - clean or replace blocked spray plate in spray head. Check if stop valves are fully open. Check for blockage in inlet filter.
	Increase in ambient water temperature.	Re-adjust flow rate to give increased flow. Select 'Low' power.
Water too cool or cold	Water flow too high.	Reduce flow rate via temperature control.
	Water pressure below minimum required (See rating label). Reduction in ambient water temperature.	Select 'High' power.
Water flow is poor	Shower head is blocked	Clean the showerhead. Ensure showerhead is as specified by manufacturer.
	The temperature control knob is set at its hottest setting.	Increase the power setting by turning the power knob to hot and increase the flow using the temperature control knob.
Water continues to drip from the handset when switched off.	Water is draining from the shower unit, after use.	This is normal, no action required. Should water continue to drip after a few minutes contact Dimplex Service Centre.
Pressure relief device has operated (water ejecting from Pressure Relief tube).	Blocked spray head.	Remove handset and run water through the shower and hose to remove any dirt that may be trapped in the system. Clean or, if possible, replace the spray plate in the spray head and then fit a new Pressure Relief Device.
	Twisted/blocked flexible shower hose.	Check the hose is not restricted anywhere along its length. Replace the hose if necessary and fit a new Pressure Relief Device.