

Project Ref:

Product Name:

Model Numbers:

DX001

Downflow Heater

FX20V



Product Description

Installed pull cord operated downflow fan heater designed for high level mounting for rapid heat distribution

Key Features

- Pull cord
- 2kW maximum output
- 1kW output selectable on installation
- Energy saving thermostat – switches to 1kW setting when room is warm (functions on 2kW setting only)
- Visual ON/OFF indicator
- Designed for high level mounting
- IPX4 rated

Technical Specification

Controls

Pull cord operation

Visual On/Off indicator

1kW/2kW output selector (internal - set up at installation)

Element

2kW stitched type with thermal fuse protection

Thermostat

None

Installation

Two key slot fixings, plus third fixing hole.

Minimum mounting height of 1.8 metres

Construction

Double insulated plastic case. Moulded in flame-retardant Nylon.

Thermal Cut Out

Manual reset cut out and thermal fuse link on element

Colour/Finish

White

Cable length

None fitted

IP Rating

IPX4

Standard Warranty

12 months

Approvals

CE and BEAB approved

Product Range Details

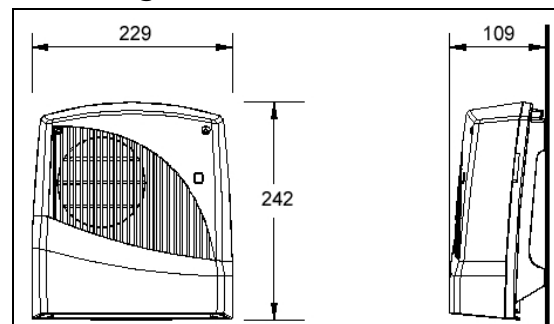

Performance	
Maximum Output	2kW
Selectable Outputs	1kW, 2kW (selectable on installation only)
Dimensions	
Height	242mm
Width	229mm
Depth	109mm
Weight	1.1kg
Packaging	
Item number	016263
Packed dimensions (h/w/d)	260 x 245 x 120 mm
Primary packing material	cardboard
Secondary packing material	1 polybag
Total packed weight	1.3kg

Additional Information

Accessories

No accessories are available for this product.