

XLS Storage Heaters

XLS 12 / XLS 18 / XLS 24

Product Description

Storage heater with automatic input charge control

Key Features

- UK's slimmest storage heater
- Automatically adjusting input charge regulator
- Room temperature boost control
- Frontal grille for efficient heat distribution
- Suitable for domestic or commercial use

Twin Sensor Technology

Two sensors are used to monitor the room and core temperatures, allowing the correct level of charge to be taken without the need for user adjustment. This can result in up to 15% in running cost saving compared with a conventional storage heater.

Technical Specification
Controls

Charge input, room temp boost

Storage Core

High density bonded magnetite bricks

Element

0.85 kW

Insulation

Front and rear: microporous silica
 Top and ends: resin-free mineral wool
 Base: calcium silicate slab

Input Charge Controller

Hydraulic, with twin internal and external sensors

Thermal Cut Out

Bimetal, manual reset

Damper Control (Boost)

Bi-metal strip

Colour/Finish

Front and side panels: Willow White
 Grille and wall spacer: Birch Grey

Cable Length

None fitted

IP Rating

IPX2 rated

Standard Warranty

12 months

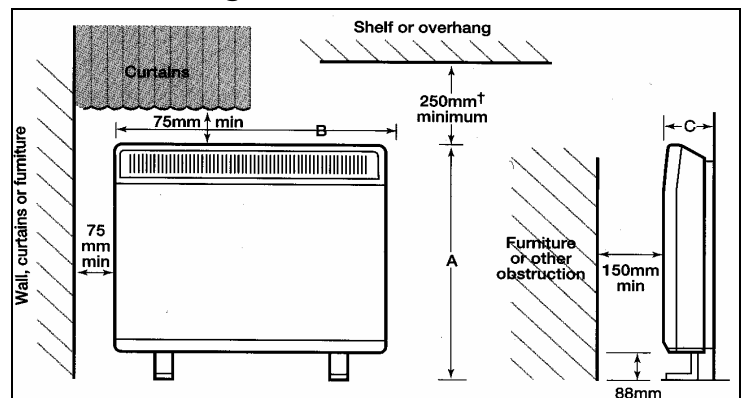
Product Range Details

XLS12
XLS18
XLS24
Performance

Input rating	1.70 kW	2.55 kW	3.4kW
Charge acceptance(7hr)	11.9 kW	17.85 kW	23.8 kW
No Elements (0.85kW)	2	3	4

Dimensions

Height (A)	706mm	706mm	706mm
Width (B)	565mm	793mm	1021mm
Depth (C)	146mm	146mm	146mm
Weight (incl. bricks)	76kg	109kg	144kg
Packed weight	20 kg	26kg	32kg

Additional Information

Storage Bricks - Packed separately in pairs – approx. weight 7.5kg each

† - When using Dimplex shelves a clearance of 150mm must be maintained

Accessories

XL9040 – Drip proof kit (IPX2 Rated)
 XL9050 – Tamper proof kit
 SHE12/18/24 – Storage Heater Shelves