

# DRAPER<sup>®</sup>

## INSTRUCTIONS FOR 1100W/1250W 230V 15L/20L Wet & Dry Vacuum Cleaners

Stock Nos. 13779  
13785

Part Nos. WDV15A  
WDV20ASS

**IMPORTANT:** PLEASE READ THESE INSTRUCTIONS CAREFULLY TO ENSURE THE SAFE AND EFFECTIVE USE OF THIS PRODUCT.



DRAPER<sup>®</sup>

### GENERAL INFORMATION

These instructions accompanying the product are the original instructions. This document is part of the product, keep it for the life of the product passing it on to any subsequent holder of the product. Read all these instructions before assembling, operating or maintaining this product.

This manual has been compiled by Draper Tools describing the purpose for which the product has been designed, and contains all the necessary information to ensure its correct and safe use. By following all the general safety instructions contained in this manual, it will ensure both product and operator safety, together with longer life of the product itself.

All photographs and drawings in this manual are supplied by Draper Tools to help illustrate the operation of the product. Whilst every effort has been made to ensure the accuracy of information contained in this manual, the Draper Tools policy of continuous improvement determines the right to make modifications without prior warning.

# 1. TITLE PAGE

---

## 1.1 INTRODUCTION:

USER MANUAL FOR:

1100W/1250W 230V 15L/20L WET & DRY VACUUM CLEANERS

Stock nos. 13779, 13785

Part nos. WDV15A, WDV20ASS

## 1.2 REVISIONS:

\_\_\_\_\_  
Date first published October 2011  
\_\_\_\_\_  
\_\_\_\_\_  
\_\_\_\_\_

As our user manuals are continually updated, users should make sure that they use the very latest version.

Downloads are available from: <http://www.drapertools.com/b2c/b2cmanuals.pgm>

DRAPER TOOLS LIMITED

HURSLEY ROAD

CHANDLER'S FORD

EASTLEIGH

HAMPSHIRE

SO53 1YF

UK

WEBSITE: [www.draper.co.uk](http://www.draper.co.uk)

PRODUCT HELPLINE: +44 (0) 23 8049 4344

GENERAL FAX: +44 (0) 23 8026 0784

## 1.3 UNDERSTANDING THIS MANUALS SAFETY CONTENT:

**WARNING!** Information that draws attention to the risk of injury or death.

**CAUTION!** Information that draws attention to the risk of damage to the product or surroundings.

## 1.4 COPYRIGHT © NOTICE:

Copyright © Draper Tools Limited.

Permission is granted to reproduce this publication for personal & educational use only.

Commercial copying, redistribution, hiring or lending is prohibited.

No part of this publication may be stored in a retrieval system or transmitted in any other form or means without written permission from Draper Tools Limited.

In all cases this copyright notice must remain intact.

---

# 2. CONTENTS

---

## 2.1 CONTENTS

<i>Page content</i>	<i>Page</i>
1 TITLE PAGE	
1.1 INTRODUCTION .....	2
1.2 REVISION HISTORY .....	2
1.3 UNDERSTANDING THIS MANUAL .....	2
1.4 COPYRIGHT NOTICE .....	2
2 CONTENTS	
2.1 CONTENTS .....	3
3 GUARANTEE	
3.1 GUARANTEE .....	4
4 INTRODUCTION	
4.1 SPECIFICATION .....	5
4.2 HANDLING & STORAGE .....	5
5 HEALTH & SAFETY INFORMATION	
5.1 GENERAL SAFETY INSTRUCTIONS FOR POWER TOOL USE .....	6
5.2 CONNECTION TO THE POWER SUPPLY .....	7A
6 TECHNICAL DESCRIPTION	
6.1 IDENTIFICATION .....	8B
7 UNPACKING & CHECKING	
7.1 PACKAGING.....	8A
8 PREPARING THE VACUUM CLEANER	
8.1 CONNECTING THE CASTORS.....	9
9 SETTING THE VACUUM CLEANER	
9.1 CHANGING SETUP FROM WET TO DRY VACUUMING .....	10
9.2 ATTACHING THE CLOTH FILTER .....	10
9.3 ATTACHING THE PAPER DUSTBAG .....	10
9.4 REFIT OF MOTOR HOUSING.....	11
9.5 CONNECTING THE FLEXIBLE HOSE .....	11
9.6 CONNECTING HAND GRIP AND EXTENSION.....	11
9.7 USE OF ATTACHMENTS.....	12
9.8 SWITCHING ON.....	12
9.9 CHANGING SETUP FROM DRY TO WET VACUUMING .....	12
9.10 WATER FEVEL .....	13
10 MAINTENANCE	
11.1 .....	14
12 EXPLANATION OF SYMBOLS	
12.1 EXPLANATION OF SYMBOLS .....	15
13 DISPOSAL	
13.1 DISPOSAL .....	16
DECLARATION OF CONFORMITY .....	ENCLOSED

### 3. GUARANTEE

---

Draper tools have been carefully tested and inspected before shipment and are guaranteed to be free from defective materials and workmanship for a period of 12 months from the date of purchase except where tools are hired out when the guarantee period is ninety days from the date of purchase.

A proof of purchase must be provided with the tool.

Should the machine develop any fault, please return the complete tool to your nearest authorized warranty repair agent or contact Draper Tools Limited, Chandler's Ford, Eastleigh, Hampshire, SO53 1YF. England. Telephone Sales Desk: (023) 8049 4333 or Product Helpline (023) 8049 4344.

If upon inspection it is found that the fault occurring is due to defective materials or workmanship, repairs will be carried out free of charge. This guarantee does not apply to normal wear and tear, nor does it cover any damage caused by misuse, careless or unsafe handling, alterations, accident, or repairs attempted or made by any personnel other than the authorised Draper warranty repair agent.

Note: If the tool is found not to be within the terms of warranty, repairs and carriage charges will be quoted and made accordingly.

This guarantee applies in lieu of any other guarantee expressed or implied and variations of its terms are not authorised.

Your Draper guarantee is not effective unless you can produce upon request a dated receipt or invoice to verify your proof of purchase within the 12 month period.

Please note that this guarantee is an additional benefit and does not affect your statutory rights. Draper Tools Limited

## 4. INTRODUCTION

---

### 4.1 SPECIFICATION

Stock no. ....	13779	.....	13785
Part no. ....	WDV15A	.....	WDV20ASS
Rated voltage .....	230~50Hz	.....	230~50Hz
Rated input .....	1100W	.....	1250W
Tank volume .....	15L	.....	20L
Vacuum pressure .....	12Kpa (120mbar)	.....	13Kpa (130mbar)
Max. airflow .....	32L/sec	.....	36L/sec
Sound pressure level .....	78dB(A)	.....	78dB(A)
Weight (excluding accessories) .....	3.7kg	.....	4.5kg

### 4.2 HANDLING & STORAGE

Although this machine is small in size, care must still be taken when handling and lifting. Dropping this machine will have an effect on the accuracy and may also result in personal injury. This machine is not a toy and must be respected.

The environment will have a negative result on its operation if you are not careful. If the air is damp, components will rust. If the machine is unprotected from dust and debris; components will become clogged: And if not cleaned and maintained correctly or regularly the machine will not perform at its best.

## 5. HEALTH & SAFETY INFORMATION

---

### 5.1 GENERAL SAFETY INSTRUCTIONS FOR POWER TOOL USE

When using any type of power tool there are steps that should be taken to make sure that you, as the user, remain safe.

Common sense and a respect for the tool will help reduce the risk of injury.

**Read the instruction manual fully.** Do not attempt any operation until you have read and understood this manual.

Most important you must know how to safely start and stop this machine, especially in an emergency.

**Keep the work area tidy and clean.** Attempting to clear clutter from around the machine during use will reduce your concentration. Mess on the floor creates a trip hazard. Any liquid spilt on the floor could result in you slipping.

**Find a suitable location.** If the machine is bench mounted; the location should provide good natural light or artificial lighting as a replacement. Avoid damp and dust locations as it will have a negative effect on the machine's performance.

If the machine is portable; do not expose the tool to rain. In all cases do not operate power tools near any flammable materials.

**Beware of electric shock.** Avoid contact with earthed surfaces; because they can conduct electricity if there is an electrical fault with the power tool. Always protect the power cable and route it away from danger.

**Keep bystanders away.** Children, onlookers and passers by must be restricted from entering the work area for their own protection. The barrier must extend a suitable distance from the tool user.

**Unplug and house all power tools that are not in use.** A power tool should never be left unattended while connected to the power supply. They must be housed in a suitable location, away locked up and from children.

**Do not overload or misuse the tool.** All tools are designed for a purpose and are limited to what they are capable of doing. Do not attempt to use a power tool (or adapt it in any way) for an application it is not designed for. Select a tool appropriate for the size of the job. Overloading a tool will result in tool failure and user injury: This covers the use of accessories.

**Dress properly.** Loose clothing, long hair and jewellery are all dangerous because they can become entangled in moving machinery: This can also result in parts of body being pulled into the machine.

Clothing should be close fitted, with any long hair tied back and jewellery and neck ties removed. Footwear must be fully enclosed and have a nonslip sole.

**Wear personal protective equipment (PPE).** Dust, noise, vibration and **swarf** can all be dangerous if not suitably protected against. If the work involving the power tool creates dust or fumes; wear a dust mask. Vibration to the hand, caused by operating some tools for longer periods must be protected against. Wear vibration reducing gloves and allow long breaks between uses. Protect against dust and **swarf** by wearing approved safety goggles or a face shield. These are some of the more common hazards and preventions; however, always find out what hazards are associated with the machine/work process and wear the most suitable protective equipment available.

## 5. HEALTH & SAFETY INFORMATION

---

**Do not breathe contaminated air.** If the work creates dust or fumes; connect the machine (if possible) to an extraction system either locally or remotely. Working outdoors can also help if possible.

**Move the machine as instructed.** If the machine is hand held, do not carry it by the power supply cable. If the product is heavy; employ a second or third person to help move it safely or use a mechanical device. Always refer to the instructions for the correct method.

**Do not overreach.** Extending your body too far can result in a loss of balance and you falling. This could be from a height or onto a machine and will result in injury.

**Maintain your tools correctly.** A well maintained tool will do the job safely. Replace any damaged or missing parts immediately with original parts from the manufacturer. As applicable; keep blades sharp; moving parts clean, oiled or greased; handles clean; and emergency devices working.

**Wait for the machine to stop.** Unless the machine is fitted with a safety brake; some parts may continue to move due to momentum. Wait for all parts to stop; then unplug it from the power supply before making any adjustments, carrying out maintenance operations or just finishing using the tool.

**Remove and check setting tools.** Some machinery requires the use of additional tools or keys to set, load or adjust the power tool. Before starting the power tool always check to make certain they have been removed and are safely away from the machine.

**Prevent unintentional starting.** Before plugging any machine in to the power supply, make sure the switch is in the OFF position. If the machine is portable; do not hold the machine near the switch and take care when putting the machine down; that nothing can operate the switch.

**Carefully select an extension lead.** Some machines are not suitable for use with extension leads. If the tool is designed for use outdoors; use an extension lead also suitable for that environment. When using an extended lead, select one capable of handling the current (amps) drawn by the machine in use. Fully extend the lead regardless of the distance between the power supply and the tool. Excess current (amps) and a coiled extension lead will both cause the cable to heat up and can result in fire.

**Concentrate and stay alert.** Distractions are likely to cause an accident. Never operate a power tool if you are under the influence of drugs (prescription or otherwise), including alcohol or if you are feeling tired. Being disorientated will result in an accident.

**Have this tool repaired by a qualified person.** This tool is designed to conform to the relevant international and local standards and as such should be maintained and repaired by someone qualified; using only original parts supplied by the manufacturer: This will ensure the tool remains safe to use.

### ***5.2 CONNECTION TO THE POWER SUPPLY***

Make sure the power supply information on the machine's rating plate are compatible with the power supply you intend to connect it to.

These vacuum cleaners come supplied with a UK standard 3 pin plug fitted. It is designed for connection to a domestic power supply rated at 230V AC.

Because it is constructed mostly of metal parts, it is a Class 1 machine; meaning, it must have an earth connection in the power supply. This is to prevent electrocution in the event of a failure.

Apart from replacing the fuse in the plug, no other electrical work is recommended on this product.





# 6. TECHNICAL DESCRIPTION

## 6.1 IDENTIFICATION



Model 13779 shown.

- ① Motor/pump housing
- ② Tank
- ③ Flexible hose
- ④ Extension tubes x 3
- ⑤ Crevice attachment
- ⑥ Antifoam filter.
- ⑦ Cloth filter.
- ⑧ Paper dust bag.
- ⑨ Double function brush (floors/liquids accessory)
- ⑩ On/off switch
- ⑪ Carrying handle
- ⑫ Accessory holders

# 7. UNPACKING & CHECKING

---

## **7.1 PACKAGING**

Carefully remove the product from the packaging and examine it for any sign of damage that may have happened during shipping. Lay the contents out and check them against the parts shown below. If any part is damaged or missing; please contact the Draper Helpline (the telephone number appears on the Title page) and do not attempt to use the lathe.

The packaging material should be retained at least during the guarantee period: in case the machine needs to be returned for repair.

Warning! Some of the packaging materials used may be harmful to children. Do not leave any of these materials in the reach of children.

If any of the packaging is to be thrown away, make sure they are disposed of correctly; according to local regulations.

## 8. PREPARING THE VACUUM CLEANER

---

### **8.1 CONNECTING THE CASTORS - FIG. 1**

Firmly press the castors into the base of the tank.



## 9. SETTING THE VACUUM CLEANER

### 9.1 CHANGING SETUP FROM WET TO DRY VACUUMING - FIG. 2

Empty the tank and dispose of any liquid which may have been picked up previously.

Remove the antifoam filter (6) (if fitted).

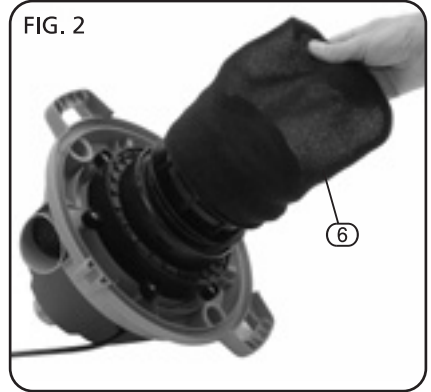

### 9.2 ATTACHING THE CLOTH FILTER - FIG. 3

Placing it beneath the motor, the cartridge filter (7) must now be fitted by pushing it on.

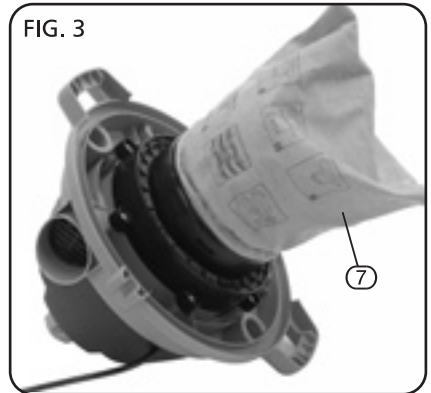

### 9.3 ATTACHING THE PAPER DUSTBAG - FIG. 4

Fix the paper dustbag (8) to the inner side of the hose connector in the tank as shown. When using the paper dust bag, dirt can be removed more hygienically and the life of the cartridge filter will be prolonged. The paper dustbag NEVER replaces the cartridge filter but, the filter cartridge can be used without the paper dustbag.

Note: As suction power decreases, replace the paper dustbag with a new one.



## 9. SETTING THE VACUUM CLEANER

### 9.4 REFIT OF MOTOR HOUSING - FIG. 5

The motor housing is secured using the two retaining clips (2.1).



### 9.5 CONNECT THE FLEXIBLE HOSE - FIG. 6

Push the flexible hose (3) into the connector. To remove the flexible hose, twist hose (2.2) anticlockwise and pull.



### 9.6 CONNECTING HAND GRIP AND EXTENSIONS - FIG. 7

Connect the hand grip to the flexible hose, and the extension tube by applying pressure. Fit the remaining extension tubes, again by applying pressure.

For disassembling, slightly turn both parts and draw apart.



## 9. SETTING THE VACUUM CLEANER

### 9.7 USE OF ATTACHMENTS - FIG. 8

The combination attachment (9.1) to be used on hard floors, parquet, cork, vinyl, ceramic, etc. Any of the other attachments may be used depending upon the specific application. They are attached in the same way as explained previously.

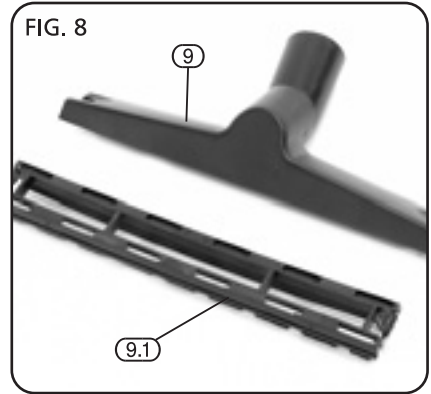

### 9.8 SWITCHING ON - FIG. 9

Now connect the vacuum cleaner to the power supply and switch the vacuum cleaner 'ON' by pushing the switch "I".

Now use the vacuum cleaner as normal.

**WARNING: EXPLOSION AND FIRE HAZARD.**

Never vacuum asbestos, inflammable fluids, such as petrol, oil, solvents, etc. Do not operate near inflammable fluids or gas. Never vacuum fluids or material hotter than 60C, such as burning cigarettes, ashes, glowing coals, etc.

If cable becomes damaged, replace immediately.

Always keep the filter cartridge clean for maximum performance.



### 9.9 CHANGING SETUP FROM DRY TO WET VACUUMING - FIG. 10

Empty the tank and dispose of any dirt/dust which may have been picked up previously.

Remove the cartridge filter if fitted.

Now fit the anti foam filter (6). This slides over the float cage as shown.

**NEVER VACUUM DRY DUST AND DIRT WITH THIS FILTER FITTED AS IT WILL PROVIDE LITTLE OR NO PROTECTION RESULTING IN MOTOR DAMAGE.**

Refit the motor housing by securing with the two retaining clips.

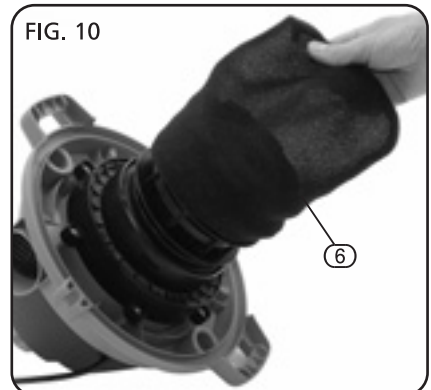

## 9. SETTING THE VACUUM CLEANER

---

### 9.10 WATER LEVEL - FIG. 11

Note: The crevice nozzle should be used when the water level is too high to use attachment.

To ensure the air flow is adequate, we recommend that the end of the nozzle is not totally immersed.

When the fluids have reached the highest permissible level in the tank, the float regulator (1.2) will cover the motor filter causing the motor to work harder, it will become noisier, at this point turn off and empty the tank.

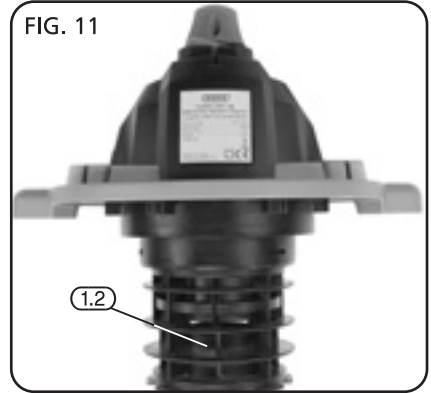

## 10. MAINTENANCE

---

Regular inspection and cleaning reduces the necessity for maintenance operations and will keep your tools in good working condition.

The motor must be correctly ventilated during the tools operation. For this reason avoid blocking the air inlets.

If the replacement of the supply cord is necessary, this has to be done by the manufacturer or his agent in order to avoid a safety hazard.

Remove the plug from the socket before carrying out adjustment, servicing or maintenance.



# 11. EXPLANATION OF SYMBOLS

---

## 11.1 EXPLANATION OF SYMBOLS



WEEE  
Do not dispose of Waste  
Electrical & Electronic Equipment  
in with domestic rubbish



For indoor use.  
Do not expose to rain.



Class II construction  
(Double insulated)

# 12. DISPOSAL

---

## 12.1 DISPOSAL

- At the end of the machine's working life, or when it can no longer be repaired, ensure that it is disposed of according to national regulations.
- Contact your local authority for details of collection schemes in your area.

In all circumstances:

- Do not dispose of power tools with domestic waste.
- Do not incinerate.
- Do not abandon in the environment.
- Do not dispose of WEEE\* as unsorted municipal waste.



\* Waste Electrical & Electronic Equipment.







- **DRAPER TOOLS LIMITED,**  
Hursley Road, Chandler's Ford,  
Eastleigh, Hampshire. SO53 1YF. U.K.
  
- **Helpline:** (023) 8049 4344
- **Sales Desk:** (023) 8049 4333
- **Internet:** [www.draper.co.uk](http://www.draper.co.uk)
- **E-mail:** [sales@drapertools.com](mailto:sales@drapertools.com)
- **Sales Fax:** (023) 8049 4209
- **General Enquiries:** (023) 8026 6355
  
- **Service/Warranty Repair Agent**  
For aftersales servicing or warranty repairs, please  
contact the Draper Tools Helpline for details of an  
agent in your local area.

YOUR DRAPER STOCKIST