

PAN/TILT FIXED MINI DOME COLOUR CAMERA



OWNER'S MANUAL

INSTALLATION AND OPERATION

**BEFORE INSTALLING OR
OPERATING THE SYSTEM,
PLEASE READ THIS MANUAL.**

MODEL: DOME P.T COLOUR

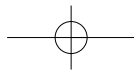

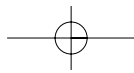

- A reliable, high quality 1/3" CCD Camera providing optimum image clarity
- Electronic Iris for use in applications with a wide spectrum of lighting
- Remote PAN/TILT control
- 3.6mm lens, 1Lux (f 2.0)
- Operating Temperature: -10°C ~ +50°C

1. Technical specification

Power source	12V (from controller)
Image sensor	1/3" interline transfer CCD
Active pixels	NTSC : 510(H) X 494(V) PAL : 768(H) X 492(V)
Image sensor area	4.8(H) X 3.7(V)mm
Signal to noise	46dB
Electronic iris	1/100.000 sec
Synchronization	Internal
Signal format	NTSC : 525 lines, 2:1 interlace PAL : 625 lines, 2:1 interlace
Video output	1.0V p-p (75 ohms)
Audio output	600 ohms line level
Ambient temperature	-10°C ~ +50°C
Ambient humidity	0-96% Non-condensing
Image sensor	1/3 - inch Color
Size camera	126 X 95 mm
Resolution	> 470 TV lines
Min. illumination	1 Lux
Lens (optional)	3.6mm
Power consumption	
wireless IR remote controller	MAX. 0.2W
controller	MAX. 1W
camera	MAX. 2.4W

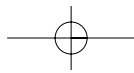

2. Installation

BEFORE YOU REGAIN INSTALLATION

- Proper safety equipment for the location and type of installation.
- Proper lift equipment to reach the installation.
- Safe feature of the lift equipment

BE SURE

- Electrical power is not connected to the dome and observation / quad monitor during installation.

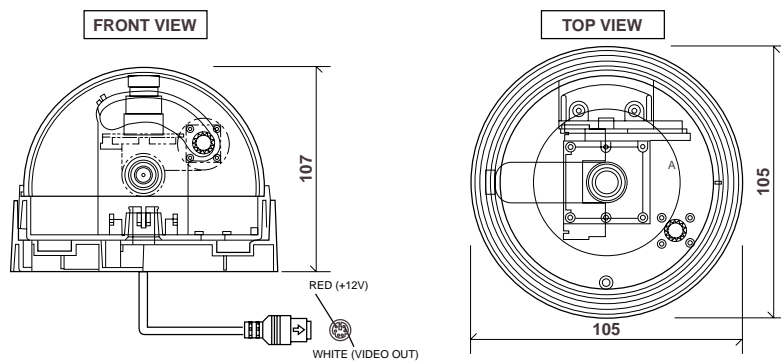

VERIFYING AND UNPACKING

- 4Ch type

Verify that all parts have arrived and their configuration is correct.

- COLOR PAN/TILT Dome Camera
- One 20m(60ft) cable (6-pin)

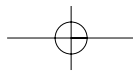

3. DIAGRAM SHOWING TYPICAL SET-UP

- 1) Example of installation of four remote dome cameras on Quad/Observation monitor system.

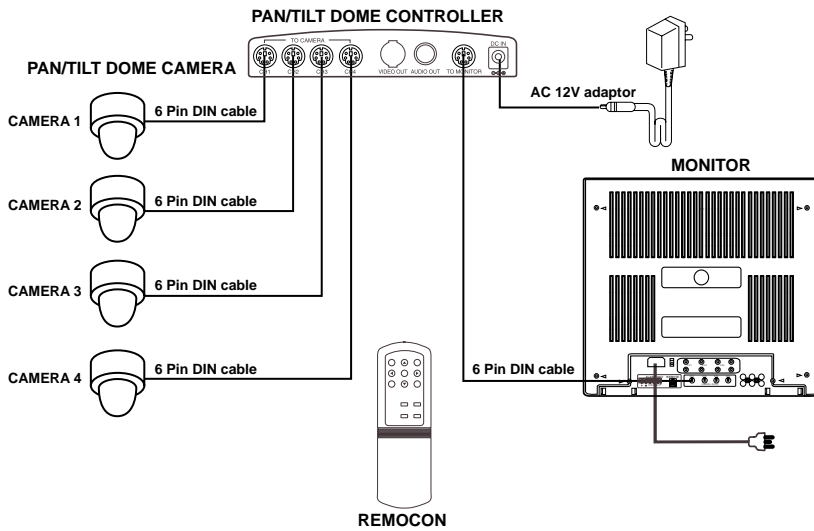

- 2) Example of installation of four dome cameras on Quad/Observation monitor system with two camera installed already.

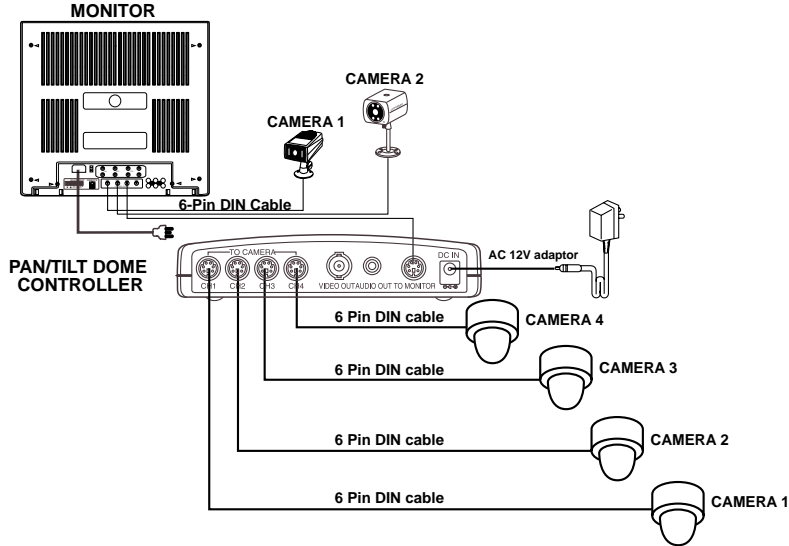

3) Example of installation of four dome camera on Slave monitor

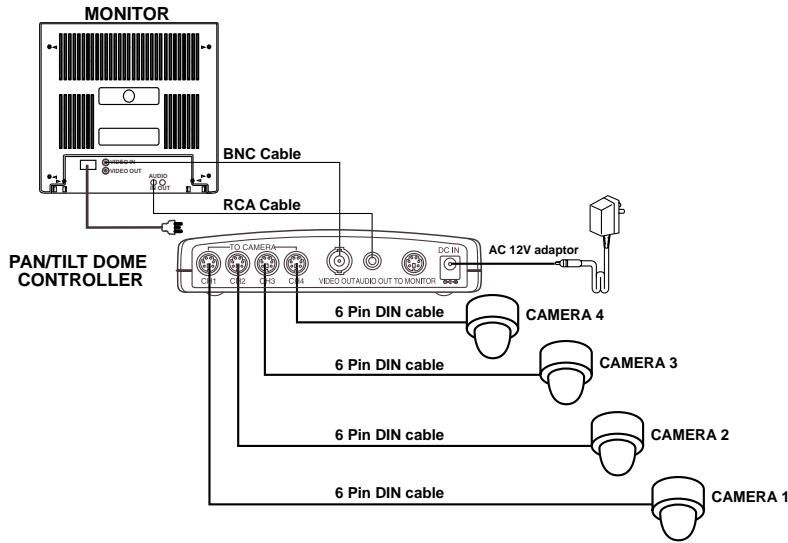

4. INSTALLATION PROCEDURE

Be sure that no power is connected to dome camera and observation / quad monitor during installation.

1. Twist open the clear dome cover to CCW to reach inside the dome camera.
2. Place the controller on the desk or proper appropriate location.
3. Connect the controller and the observation / quad monitor with 10ft din cable. (Included in the package of controller)
4. Wiring the 60ft din cable from controller to dome camera.
5. Attach the adaptor plate on the ceiling. Using M3 X 20 screws (included)
6. Twist the base of the dome camera to the adaptor plate on the ceiling.



Do not hold clear bubble or swivel, when you attach the dome to adaptor plate.

7. Attach one end of DIN connector to the back of the control unit's connector. (named camera)
8. Repeat sequence 1 through 9 until install all dome cameras.
9. Insert two AAA size batteries (not included) into IR remote controller.

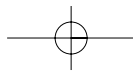

5. Key components

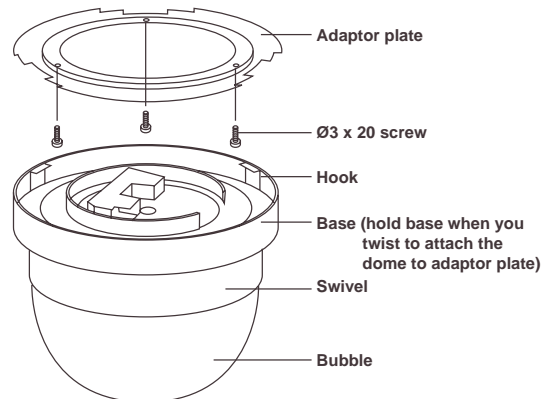

6. Guarantee and Service Information

1. Your new PAN/TILT mini dome camera guaranteed free from defects in materials and workmanship for a period of one year from the date of purpose.
2. The product must have been used only for its intended purpose, and not been subjected to damage by misuse, wilful or accidental damage, damage caused by excessive voltage or lightning.
3. The system must have been installed in accordance with the instructions given in the instruction manual and only compatible equipment may be connected to it.
4. The product must not have been tampered with or repaired by anyone other than betacom phonemend or its authorized service agents.
5. Should the serial numbers be tampered with in any way then the guarantee will be considered null and void.
6. This guarantee does not affect your statutory rights.

In the event of a fault

1. Carefully check that the installation has been carried out in accordance with the instructions.
2. Only return the unit/system if you are absolutely certain it is faulty, otherwise a charge may have to be made.
3. Should a fault persist, contact your system installer for guidance.
4. If the problem persists, your system installer will arrange repair of the faulty unit. Alternatively you may return the defect item to please enclose a note stating the nature of the fault TOGETHER. WITH PROOF OR PURCHASE.

IMPORTANT

Further charges may be incurred if this product is outside the guarantee period (in which case you will be sent a repair estimate), or if the repairs are not covered by the guarantee. PLEASE RETAIN ALL ORIGINAL PACKAGING IN THE EVENT THAT YOU NEED TO RETURN AN ITEM FOR SERVICE. THIS REDUCES THE RISK OF DAMAGE IN TRANSIT.

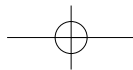

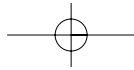

7. Technical Help

PLEASE PHONE OUR HELPLINE

0121 786 1881

OR SEND A FAX

0121 789 8055

OR AN E-MAIL

ESP1CCTV@ aol.com

“ Please note. Users of CCTV systems where recording is taking place should be aware of their responsibilities under the Data Protection Act 1998. Further information can be found on the website www.dataprotection.gov.uk ”

