

Table 2

FIRE DETECTOR Class	Application temperature		Operational temperature	
	typical	maximum	minimum	maximum
	°C	°C	°C	°C
A1	25	50	54	65
A2	25	50	54	70
B	40	65	69	85

Table 3

Rate of rise	Class A1		Class A2,B	
	Lower limit	Upper limit	Lower limit	Upper limit
	°C/min	min/sec	min/sec	min/sec
1	29:00	40:20	29:00	46:00
3	7:13	13:40	7:13	16:00
5	4:09	8:20	4:09	10:00
10	1:00	4:20	2:00	5:30
20	0:30	2:20	1:00	3:13
30	0:20	1:40	0:40	2:25

TECHNICAL HELP LINE 0121 786 1881



FIXED TEMPERATURE HEAT DETECTOR

FHD-1



1. INTRODUCTION

The FHD-1 fixed temperature heat detector is designed to provide early warning of a fire condition reacting upon ambient temperature reaching a fixed temperature threshold.

2. TECHNICAL DATA

- 2.1. Supply voltage - **22,5 (±7.5) VDC**
- 2.2. Average current consumption in quiescent state - **40 µA at 22,5 V DC**
- 2.3. Alarm state current - **(16 ± 2) mA at 22,5V DC**
- 2.4. Sensitivity – according EN54 / 5 Standard - **Class A1S (Table 2)**
- 2.5. Period of transition from quiescent to alarm state upon rise in the ambient temperature - **according the EN 54 / 5 (Table 3)**
- 2.6. Permanent magnet test option - **available**
- 2.7. Connection to fire control panel - **two wire**
- 2.8. Remote indicator option - **available**
(connection is made through a build in 1k resistor)
- 2.9. Level of protection - **IP 30**
- 2.10. Operational temperature range - **minus 10°C / plus 90°C**
- 2.11. Protected area - **35 m² at 3,5 m height**
- 2.12. Relative humidity resistance - **(92⁺³₋₃) % at 40°C**
- 2.13. Dimensions (with a DB-1 type base)
 - diameter - **∅106 mm;**
 - height - **48 mm**
- 2.14. Weight (incl. base) - **0,145 kg**

3. STRUCTURE AND FUNCTION

The FHD-1 consists of two main parts: a base and a detector head. The latter comprises a circuit board. The detector head is fixed on the base by the means of bayonet joints. When locating the detector head on the base, make sure the bench mark stands about 20 mm before the respective bench mark on the base; then rotate clockwise to fix. The bench marks should fully coincide when fixed.

The contact plates are fixed to the base. The connection between the incoming wires and the contact plates is made by the provided screws and washers.

The circuit board is mounted within the detector head. The contact blades are placed on the detector heads' underside. The electric connection with the circuit board is provided by retainer screws.

The electronic components are located on the either sides of the circuit board and the FHD-1's heat sensitive elements are on the detector heads' underside.

A flat pivot point screw is provided on the detector head to prevent unauthorized removal. A 2 mm tip screwdriver is required for locking and unlocking.

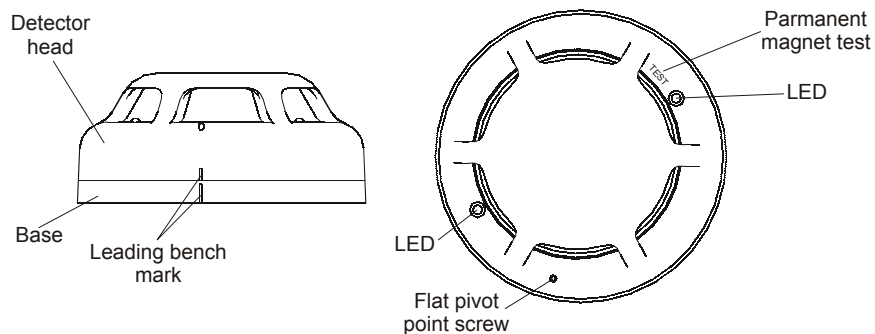

Fig. 1

The principle of function of the FHD-1 is based on the ohmic resistance alteration in the thermistor as a result of the ambient temperature change. The FHD-1 detects presence of a specific fixed temperature by sensing an alteration in circuit resistance caused by changes in the state of the thermistors. Upon activation the FHD-1 illuminates two red LEDs, situated on the detector head (360° visibility). The LEDs can be reset and extinguished by momentarily removing the power source.

Detector's type and sensitivity are marked.

4. PREPARING THE FHD-1 FOR OPERATION

4.1. Mounting

Separate the base from the detector head by turning the detector head in an anti-clockwise direction.

Feed the connection cable through the cable entry in the center of the base. Fix the base on the ceiling using appropriate fixings. Complete the wiring as shown on fig. 2.1 or 2.2. Replace the detector head on the base by offering the detector head to the base ensuring bench marks are no more than 20 mm apart. Rotate the detector head in a clockwise direction to complete location.

Lock the detector head to the base by screwing the flat pivot point screw, using a 2 mm tip screwdriver, ensure not to over tighten.

4.2. Electrical connection

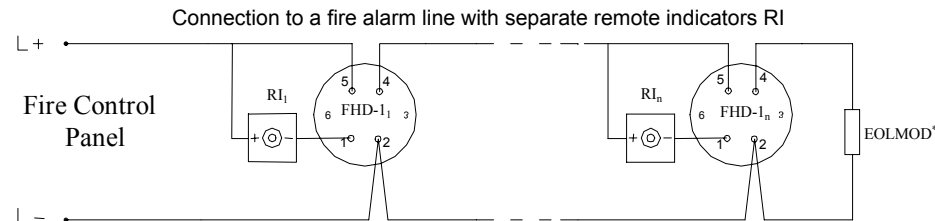

Fig. 2.1

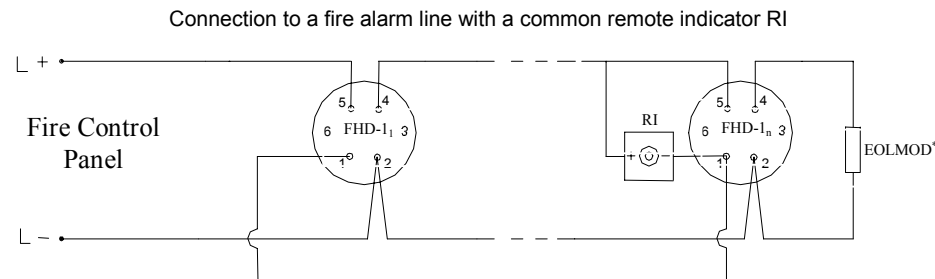

Fig. 2.2

* EOLMOD – End of line module

4.3. Testing

Apply power in the range of 15 - 30V DC. Place a permanent magnet on the detector heads surface at the point marked test periphery. The twin LEDs will illuminate. After removing the magnet the LEDs should remain lit until reset by momentary interruption of the power supply. In addition a simulation test of real fire conditions should be completed in a laboratory heat tunnel.

5. SERVICE SCHEDULE

Table 1

	Task	Periodicity
1.	Check for physical damage	weekly
2.	Test correct operation	monthly
3.	Preventive cleaning against dust contamination	every 6 months
4.	Preventive cleaning and inspection of contacts	Annually

6. WARRANTY

The manufacturer guarantees compliance with EN 54 Standard, Part 5. The warrant period is 36 months from the date of manufacture, providing that requirements stated in the service schedule (5) have been observed.