

EL-2620

The EL-2620 is a wireless keypad for use with the *infinite Prime* control system. This keypad is primarily designed as an additional arming station, including three arming keys that enable Full, Part or Perimeter arming modes. Pressing the Full and Perimeter buttons simultaneously generates an SOS panic alarm. Additionally, the keypad may be used to control Home Automation modules.

The Cancel key, , clears the keypad in the event that a key is pressed by mistake while entering a code, for example. This key causes the keypad to disregard what was previously entered enabling the user to start again.

Registration

1. Set the receiver to Registration mode.
2. Press a button on the keypad making sure that one of the Battery LEDs lights up when the button is pressed.
3. Wait for five seconds and press the same button again.

Note: Alternatively, the EL-2620 can be registered to the receiver by manually entering the transmitter's serial number.

Battery Replacement

Every time a key is pressed, one of the battery status LEDs is lit. When the battery needs to be replaced, the red Low Battery LED is lit.

To replace the battery:

1. Remove the back cover by inserting a small screwdriver into the pry-off slots at the bottom of the unit and twisting.
2. Observing correct polarity, replace the battery.
3. Replace the back cover.

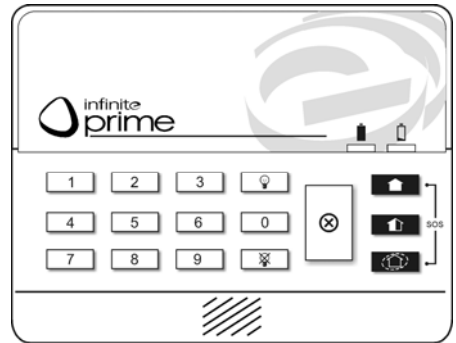

Figure 1: EL-2620 (front view)

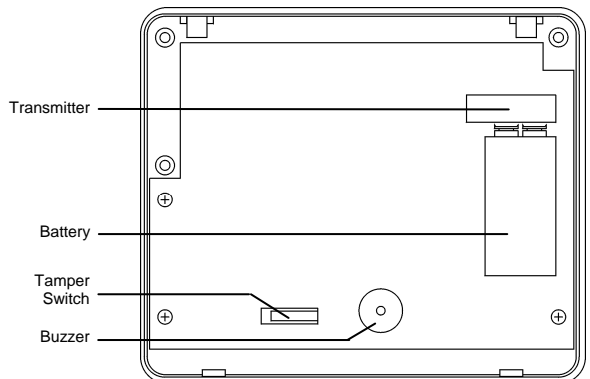

Figure 2: EL-2620 (back cover off)

Technical Specifications

Antenna: Printed on PCB
Frequency: 868.35, 433.92, 418 or 315MHz FM
Current Consumption: 26mA (transmission)
2 μ A (standby)

Power: 9V Alkaline Battery
RFI Immunity: 40V/m
Operating Temperature: 0 - 60°C
Dimensions: 130 x 110 x 28mm



Electronics Line 3000 Ltd.

Electronics Line 3000 Ltd.: 2 Granit Street, Kiryat Arie, POB 3253, Petah Tikvah 49130 Israel. Tel: (972-3) 918-1333, Fax: (972-3) 922-0831

USA: 5637 Arapahoe Avenue, Boulder, Colorado 80303. Tel: (800) 683-6835, Fax: (303) 938-8062

UK: Unit 7, Leviss Trading Estate, Station Road, Stechford, Birmingham B33 9AE. Tel: (44-121) 789-8111, Fax: (44-121) 789-8055

SecTecGLOBAL: 156 West 56 Street, Suite 1605, New York, NY 10019, United States, Tel: (1-212) 2652400, Fax: (1-212) 2652419

All data is subject to change without prior notice. In no event shall Electronics Line 3000 Ltd. (EL3K) be liable for an amount in excess of EL3K's original selling price of this product, for any loss or damage whether direct, indirect, incidental, consequential or otherwise arising out of any failure of the product. Hereby, Electronics Line 3000 Ltd. declares that this keypad is in compliance with the essential requirements and other relevant provisions of Directive 1999/5/EC.

