

Cube

36

CHIMNEY / DECORATIVE

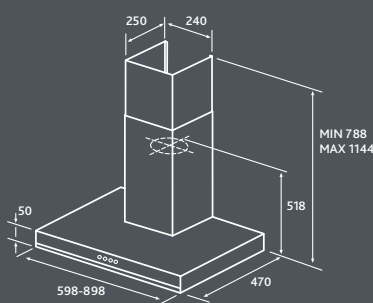

| | |
|--------------------------|---|
| Finish | Stainless steel with glass |
| Controls | 3 speed illuminated soft push buttons |
| Lights | 2 x 20w halogen lamps |
| Grease filter | Professional washable metal grease filter |
| Ducting connector | 150mm (6in) diameter ducting connector |
| Available size | 600mm or 900mm |
| Maximum airflow | 750 m ³ /h |
| IEC airflow | 630 m ³ /h |
| Noise level | 46-64 dB(A) |
| Power consumption | 220w |
| | Smart installation system |
| | Optimised aspiration system |
| | Also available with 1200 m ³ /h external motor |
| Charcoal Filter | F00262/2S |

| | Description | Code | |
|---------|--------------|-----------|-------------------------------------|
| CUBE 60 | CUBE IX/A/60 | 51713693* | * external motor versions available |
| CUBE 90 | CUBE IX/A/90 | 51713694* | |