

# Focus

CHIMNEY / DECORATIVE

39

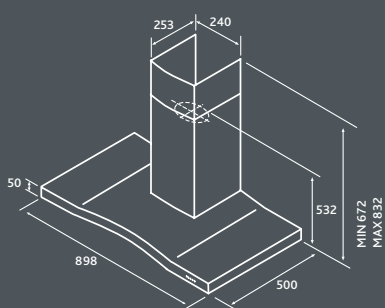

<b>Finish</b>	Stainless steel
<b>Controls</b>	3 speed electronic touch control + boost with filter saturation indicators
<b>Lights</b>	4 x 20w halogen lamps
<b>Grease filter</b>	Metal washable grease filter
<b>Ducting connector</b>	150mm (6in) diameter ducting connector
<b>Available widths</b>	900mm
<b>Maximum airflow</b>	800 m <sup>3</sup> /h
<b>IEC airflow</b>	650 m <sup>3</sup> /h
<b>Noise level</b>	46-64 dB(A)
<b>Power consumption</b>	220w
	Smart installation system
	Optimised aspiration system
<b>Charcoal Filter</b>	F00262/2S

	Description	Code
FOCUS	FOCUS TC IX/A/90	47514619