

Stenar

38

CHIMNEY / DECORATIVE

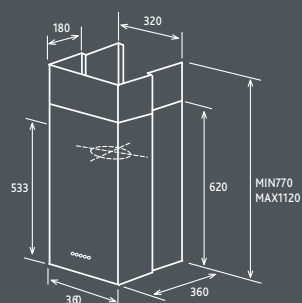

Finish	Stainless steel
Controls	3 speed push buttons
Lights	2 x 20w halogen lamp
Grease filter	Professional washable metal grease filter
Ducting connector	150mm (6in) diameter ducting connector
Available widths	360mm
Maximum airflow	750 m ³ /h
IEC airflow	630 m ³ /h
Noise level	46-64 dB(A)
Power consumption	220w
Charcoal Filter	Smart installation system Optimised aspiration system F00262/2S

	Description	Code
STENAR	STENAR IX/A/36	61212733