

# Twin

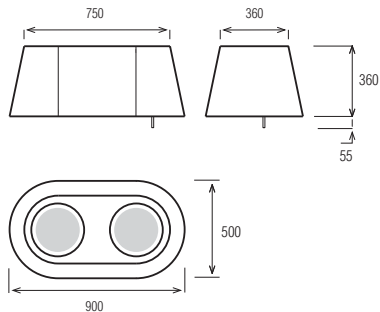

<b>Finish</b>	Stainless steel
<b>Controls</b>	3 speed illuminated 'Magic Wand' touch sensor + boost
<b>Lights</b>	2 x 40w halogen lamp + 6 x 40w lamps
<b>Grease filter</b>	Metal washable grease filters & long-life odour filters included
<b>Available widths</b>	900 mm
<b>Maximum airflow</b>	1000 m <sup>3</sup> /h
<b>Maximum airflow</b>	560 m <sup>3</sup> /h (recycling )
<b>IEC airflow</b>	800 m <sup>3</sup> /h
<b>Noise level</b>	45-65 dB(A)
<b>Power consumption</b>	520w
	Ceiling mounted 'Evolution' system

<b>Charcoal Filter</b>	F00433
------------------------	--------

Description	Code
-------------	------

<b>Twin</b>	TWIN IX/F 90	65414590/1
-------------	--------------	------------

<b>Kit Remote Control</b>	KIT REMOTE CONTROL	KIT02183
---------------------------	--------------------	----------