



FAN STORAGE HEATERS



ADL 5030
ADL 4024
ADL 3018
ADL 2012

INSTALLATION INSTRUCTIONS AND USER GUIDE

(To be left with end user)

Please read these instructions before installing or using this appliance for the first time.

WARNING

- Please read these instructions before installing or using this appliance for the first time. The warranty of the storage heater will not cover any damage caused by non observance of any of these instructions.
- This Guide must be kept and given to any new owner.
- The installation of the heater should be carried out by trained personnel.
- The use of storage heaters is forbidden in any area where there is a presence of gases, explosives or inflammable objects.
- Do not dry clothes on or over heater.
- Do not place objects in contact with the heater.
- Do not cover this heater at any time.
- The air outlet grille at the bottom of the heater cabinet and the air inlet at the right side of the heater are provided to ensure the most efficient operation of the appliance. They also protect the heater from overheating; therefore, it is essential that at no time they are covered.
- This heater should be switched OFF at the isolating switch before any repair work is carried out. Switch off during the times of year when heat is not required.
- The installation of the heaters must be carried out in such a way that each pole can be disconnected from the supply having a contact separation of at least 3 mm.
- The storage heater should not be installed just bellow an electrical socket.
- The appliance must be installed in such a way that it is impossible for anyone using a bath or shower to touch the controls.
- The nominal charging time of this storage heater must be controlled by means of a programmer.
- The installation must be carried out in accordance with the current electrical regulations.
- This appliance must be earthed.
- Storage fan heaters need an ambient thermostat to operate (not included).
- After installation, a survey of the first charging cycle should be carried out to ensure that the main input thermostat switches OFF. Ventilate the room during this first cycle.
- Never open a charged heater.
- The presence in the air of particles of smoke, dust and other pollutants could, in time, discolour the walls and surfaces around the heater. To maintain stability, it is essential that the heater is placed on a level surface and care should be taken to avoid irregular surfaces, such as may result from carpets or tiled surrounds partially protruding under the heater.
- Should the heater be moved and reinstalled, it is essential that the work is carried out by trained personnel.
- If during any reinstallation the thermal insulation shows any sign of damage, it is necessary for the faulty part to be removed and replaced by the identical part.

INTRODUCTION

Storage heaters are designed to take advantage of the considerable economic benefits of off-peak electricity.

Model	Voltage	Input kW	Bricks	Weight kg	L cm	W cm	H cm
ADL-2012	230/400V 3N~	2	12	121	63	24*	66
ADL-3018	230/400V 3N~	3	18	173	81	24*	66
ADL-4024	230/400V 3N~	4	24	225	99	24*	66
ADL-5030	230/400V 3N~	5	30	277	117	24*	66

* 2.5 cm Wall separation

The input control operates a highly sensitive thermostat that regulates the amount of heat stored.

The discharge takes place when the built-in fan operates. The fan drives fresh air through the core and is heated. A bimetallic device mixes the hot air with fresh air to provide homogeneous temperature.

It is important that the correct rating of heater is installed to provide the selected level of heat. This will ensure the best possible running costs against other fuels.

To avoid transport problems, the heater casings and storage bricks are packed separately. The bricks with some slight defects in the corners can be used.

You should be aware that storage heaters, when fully charged, can have high surface temperatures.

INSTALLATION INSTRUCTIONS

1. Choose a suitable place to install the heater. It is necessary that a minimum clearance of 50 cm between the heater and combustible materials such as furniture and curtains must be allowed to ensure the best heating results.
2. Open the carton at the indicated side. *Remove the boxes* that contain the accessories bag, the heating elements, the anti-tilt bracket, and LH & RH spacers. Check that it is the correct model and that it is in good condition.
3. The anti-tilt bracket should be securely attached to the wall, 61 cm from the floor (Figure 1). Drill the required holes into the wall.

Note: This device prevents the heater overturning when a force of up to 20 kg is applied to the upper parts towards the exterior. The function of the device is not to hang the heater. If there is any doubt as to the strength of the wall, please consult an expert. Storage heaters are very heavy and the installer must ensure that they are securely fixed and that there is no possibility of them overturning.

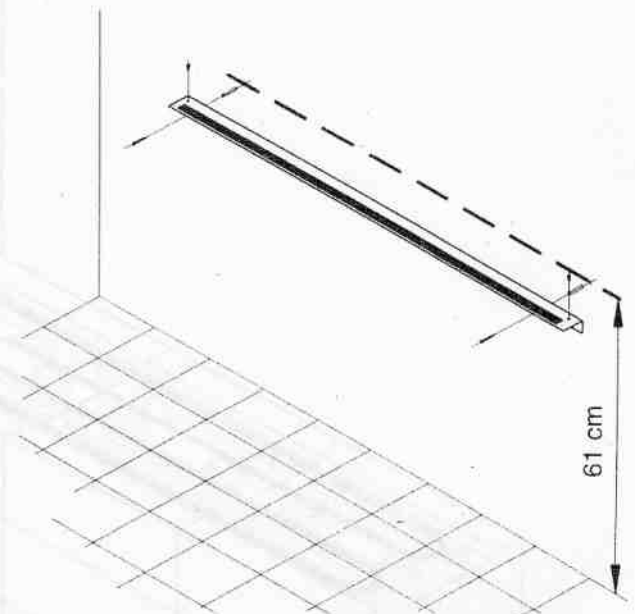

Fig. 1

4. Remove the front outlet grille by removing the four screws. Remove also the front panel by removing the two screws at the bottom of the heater.
5. Attach the LH & RH spacers to the storage heater using the screws supplied, in the same way as the screws are fixed in the upper rear section of the heater side. Check the heater is separated 25 mm from the wall at the top and bottom of the heater (Figure 2). Fit and screw the appliance to the anti-tilt device.
6. Remove the inner front panel. **Warning. At the other side of this front panel there is a breakable thermal insulation panel. It must be handled with care. Avoid touching it.**
7. Place a row of storage bricks carefully and insert one of the heating elements in the holes in the right side insulation (Figure 3).
8. Check that the heating element rests completely on the bricks without restricting a new row.
9. Arrange two new rows of bricks, ensuring the

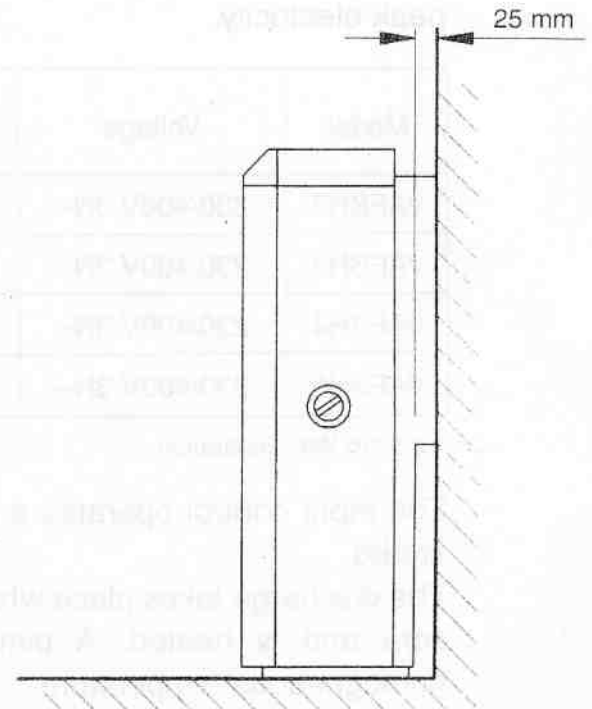

Fig. 2

flat side is facing towards the bottom of the heater, and insert a new heating element. Repeat the operation for the third heating element. Place the last row of bricks also with the flat side toward the bottom of the heater.

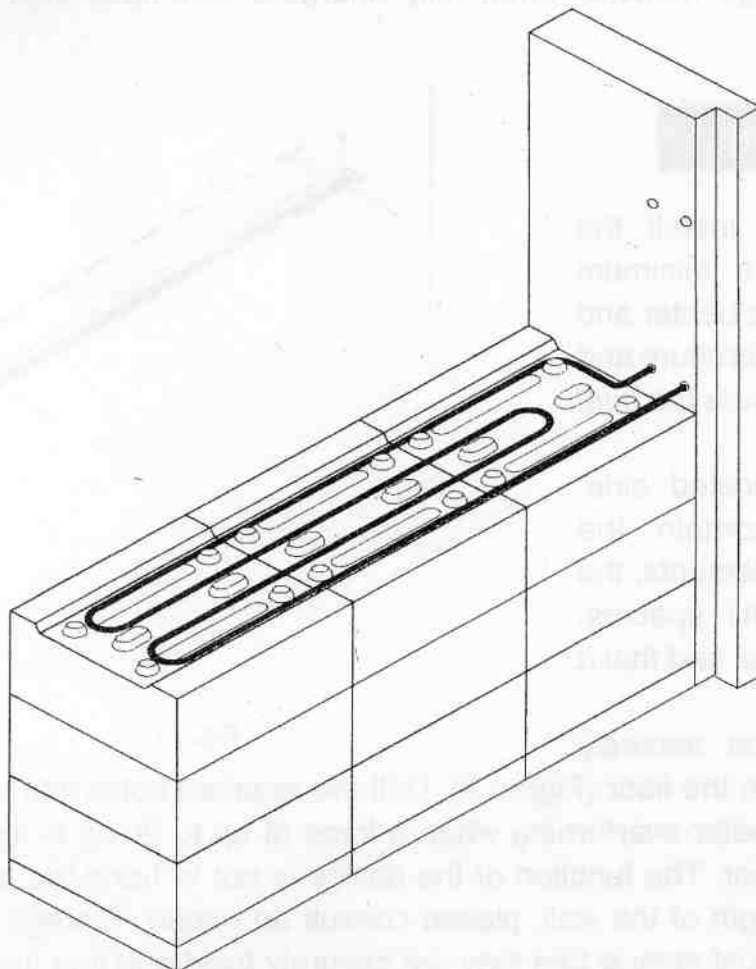

Fig. 3

10. Connect the heater using the enclosed wiring diagram. Ensure all connections are correct and that no connection is damaged. Do not leave any remaining wire inside the heater.
11. Refit the inner front panel. If the bricks have been fitted correctly you will find no difficulty in refitting the panel. Attach the front panel by hanging it on the "V" in the upper part and securing it at the bottom with the two screws provided. Fit the outlet grille with the four screws.

USING THE FAN STORAGE HEATER

The control at the right side of the heater regulates the heat input. The input control has five settings, numbered “1” to “5”. During mild weather, it is normal to set the input control in a medium position. In cooler weather, the control should be set at 5 to give maximum heat retention.

For models without remote control, the discharge of the storage heater requires an ambient thermostat to control the operation of the fan. Maximum comfort is obtained when an ambient digital timer thermostat is used, which as well as regulating temperature can be programmed to operate at the desired time.

MAINTENANCE OF YOUR FAN STORAGE HEATER

This storage heater does not require any special care. During the first few charges you may be aware of an unusual odour. This is normal, and if it happens, please ventilate the room until the odour disappears. If dust accumulates on the heater surface, it can be removed using a wet cloth when the heater is cold. Do not use solvents or abrasive products.

WIRING DIAGRAM

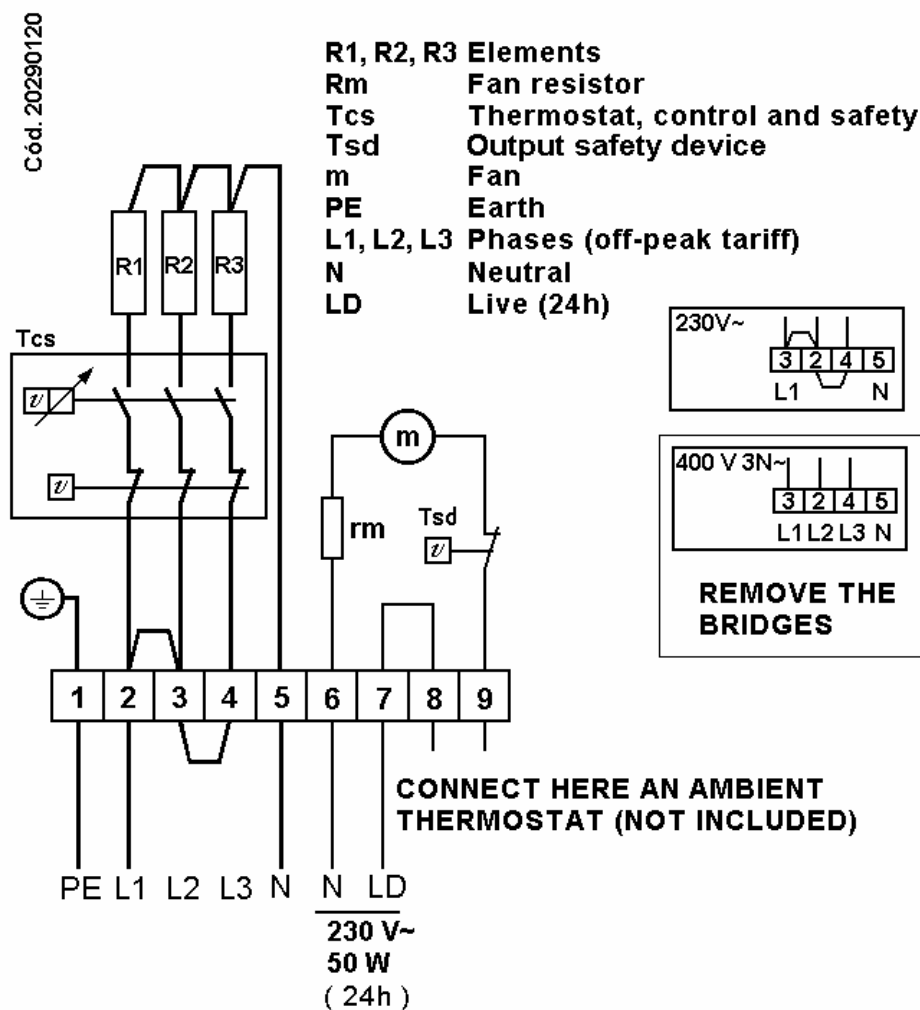



The symbol on the product or in its packaging indicates that this product may not be treated as household waste. Instead it shall be handed over to the applicable collection point for the recycling of electrical and electronic equipment. By ensuring this product is disposed of correctly, you will help prevent potential negative consequences for the environment and human health, which could otherwise be caused by inappropriate waste handling of this product. For more detailed information about recycling of this product, please contact your local city office, your household waste disposal service or the shop where you purchased the product. These instructions are only valid in the EU member states.

YOUR 24 MONTH GUARANTEE

Your new appliance comes with a 24 month guarantee protecting you against electrical and mechanical breakdown.

For servicing during the first 24 months telephone 01942673620, or contact your local supplier:

CONDITIONS

THESE DO NOT AFFECT YOUR STATUTORY RIGHTS

Your appliance carries a free guarantee which protects you against the cost of repairs in the first 24 months from date of purchase provided;

- a. Claims are accompanied by evidence of the date of purchase, such as a sales receipt.
- b. The appliance was correctly installed and operated in accordance with the manufacture's instructions and used solely for domestic/commercial purposes.
- c. The defect was not due to accident, misuse, unauthorised modification or repair by an unqualified person.
- d. Parts, such as fuses in plugs, which require routine replacement, are excluded from guarantee.

YOUR GUARANTEE IS VALID ONLY IN THE UK.

As a part of the policy of continuous product improvement Elnur s.a reserves the right to alter specifications without notice.