

Wiring diagrams

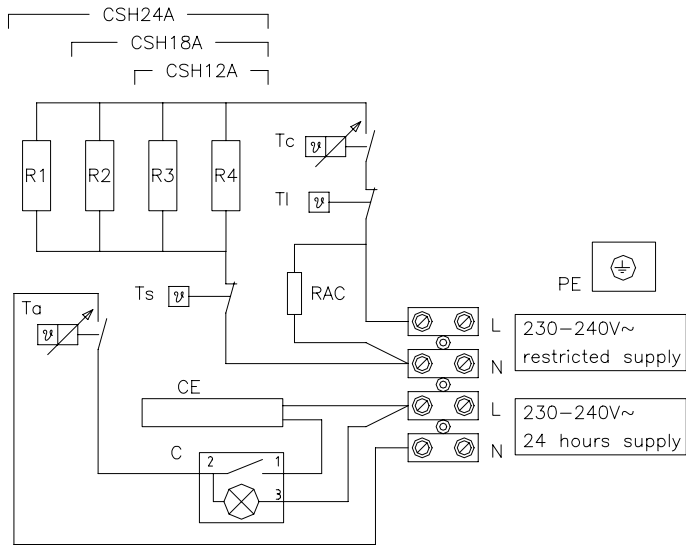

- |                                   |   |
|-----------------------------------|---|
| R1, R2, R3, R4...Heating elements | CE..... Convector element with built in thermal cut out |
| RAC.....Accelerating resistance   | C..... Switch   |
| Tc.....Charge control thermostat  | PE..... Earth   |
| Ts.....Safety cut out             | L.....Phase   |
| Tl.....Temperature limiter        | N..... Neutral  |
| Ta.....Ambient thermostat         |   |

**IMPORTANT**

This equipment is supplied with a main connector. All the wires must be coloured in accordance with the following code:

Green & Yellow – Earth      Blue – Neutral      Brown - Live.

# COMBINED STORAGE HEATERS

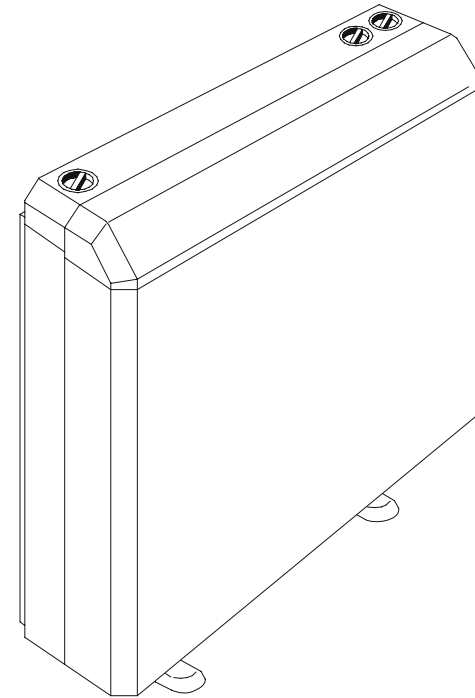

<b>CSH12</b>	<b>CSH12A</b>
<b>CSH18</b>	<b>CSH18A</b>
<b>CSH24</b>	<b>CSH24A</b>

INSTALLATION INSTRUCTIONS  
AND  
OWNERS GUIDE

**To be left with end user**

**WARNING**

- Please read these instructions before installing or using this appliance for the first time. The warranty of the combined storage heater will not cover any damage caused by non observance of any of these instructions.
- This Guide must be kept and given to any new owner.
- The installation of the heater should be carried out by trained personnel.
- Should the heater be moved and reinstalled it is essential that the work is carried out by trained personnel.
- If during any reinstallation the thermal insulation shows any sign of damage, it is necessary for the faulty part to be removed and replaced by an identical part.
- The use of storage heaters is forbidden in any area where there is a presence of gases, explosives or inflammable objects.
- Do not use this heater to dry clothes.
- Do not cover this heater at any time.
- Do not place objects in contact with the heater.
- The air outlet grill at the top of the heater cabinet and the air inlet at the bottom of the heater are provided to ensure the most efficient operation of the appliance. They also protect the heater from overheating, therefore, it is essential that at no time are they covered.
- This heater should be switched off at the isolating switch before any repair work is carried out. This action should also be taken during the times of the year when heat is not required.
- The installation of the heaters must be carried out in such a way that each pole can be disconnected from the supply having a contact separation of at least 3 mm.
- The storage heater should not be installed just below an electrical socket.
- The appliance must be installed in such a way that it is impossible for anyone using a bath or shower, to touch the controls.
- The nominal charging time of this storage heater must be controlled by means of a programmer.
- The installation must be carried out in accordance with the current electrical regulations.
- This appliance must be earthed.
- After installation a survey of the first charging cycle should be carried out to ensure that the main input thermostat switches off. Ventilate the room during this first cycle.
- Before carrying out any work inside the appliance, the heater must be disconnected from the electricity supply.
- Never open a charged heater.
- The presence in the air of particles of smoke, dust and other pollutants could, in time, discolour the walls and surfaces around the heater.
- To maintain stability, it is essential that the heater is placed on a level surface and care should be taken to avoid irregular surfaces, such as may result from carpets or tiled surrounds partially protruding under the heater.

By leaving in this position, the heater will automatically maintain the selected temperature. It is recommended to switch off the convector at the beginning of the overnight charge.

**Models CSH12A, CSH18A and CSH24A:**

The direct acting convector element should be switched off prior to the storage heaters night time charge period engaging. This is to avoid the possibility of the automatic charge regulator reducing the total charge taken, due to it reading a high room temperature.

**MAINTENANCE OF YOUR COMBINED STORE HEATER**

This storage heater does not require any special care. During the first few charges you may be aware of an unusual odour. This is normal and if it happens, please ventilate the room until the odour disappears.

If dust accumulates on the heater surface it can be removed using a wet cloth when the heater is cold. Do not use solvents or a abrasive products.

**WIRING DIAGRAMS**

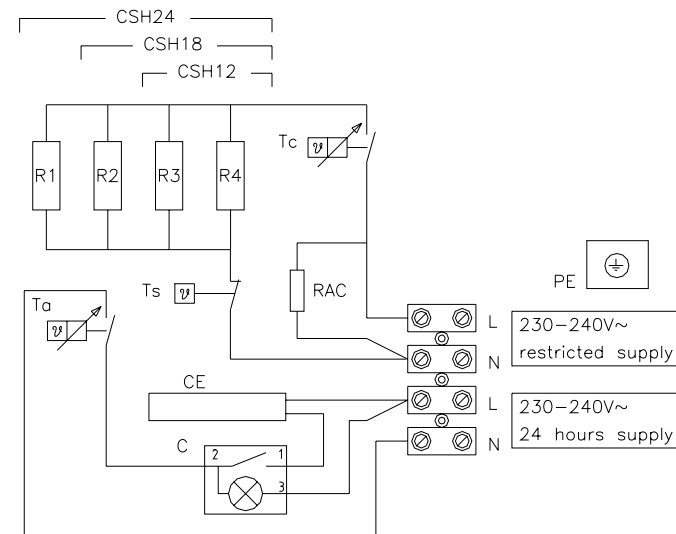

- |                   |                           |         |   |
|-------------------|---------------------------|---------|---|
| R1, R2, R3, R4... | Heating elements          | CE..... | Convector element with built in thermal cut out |
| RAC.....          | Accelerating resistance   | C.....  | Switch  |
| Tc.....           | Charge control thermostat | PE..... | Earth   |
| Ts.....           | Safety cut out            | L.....  | Phase   |
| Ta.....           | Ambient thermostat        | N.....  | Neutral   |

3.- Take off the front panel by removing the two screws at the bottom of the heater.

4.- Set the heater in the selected installation area and mark the fixing points on the wall using a pencil.

Use the heater fixing holes as a template and mark the wall through the fixing holes. Drill the required holes into the wall.

Fix the heater to the wall.

Please note the weight of the heater is taken by the feet, the wall fixing screws are only to prevent the heater overturning. If there is any doubt as to the strength of the wall please consult an expert. Storage heaters are very heavy and the installer must ensure that they are securely fixed and that there is no possibility of them overturning.

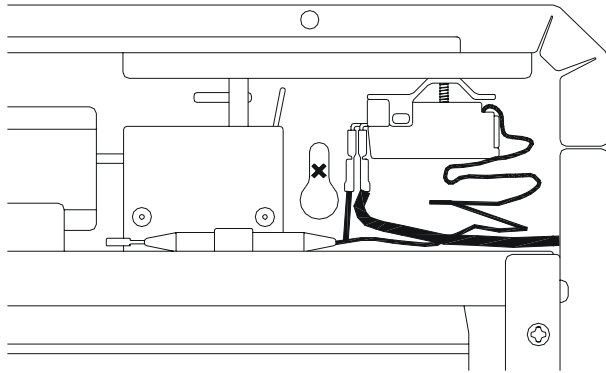

Fig.2

5.- Connect the heater using the enclosed wiring diagram. Ensure that all connections are firm.

**The “restricted supply” leads must be connected to a supply controlled by means of a programmer.**

The “unrestricted supply” leads must be connected to a 24 hours supply. Use silicone covered wire.

Do not leave any remaining wire inside the heater. Do not connect the convective element yet.

6.- Remove the inner front panel with the attached convective element.

**Warning. At the other side of this front panel there is a breakable thermal insulation panel. Both sides must be handle with care. Avoid touching the insulation and the convective element.**

7.- Do not disconnect the electrical elements. Remove the packaging then lift and recline the elements.

8.- Place the storage bricks carefully, with the flat side facing the back of the heater. Arrange two rows of bricks (fig 3).

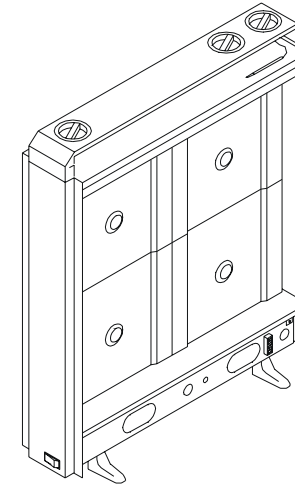

Fig.3

9.- Fix the elements in their original position. Place the other two rows of bricks with the knobs face to face.

10.- Refit the inner front panel. If the bricks have been fitted correctly you will find no difficulty in refitting the panel (fig 4).

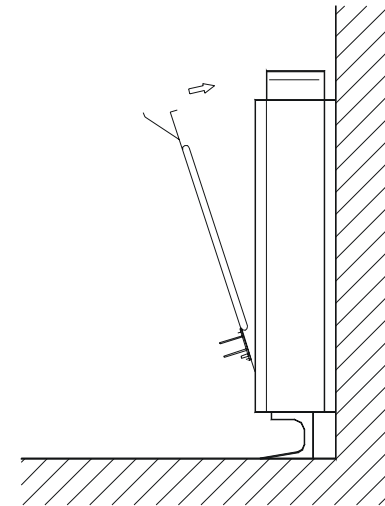

Fig.4

11.- Connect the convective element using the two free fast-on terminals. Follow the enclosed diagram.

12.- Attach the front panel and fix it at the bottom edge with the two screws provided.

## USING THE COMBINED STORAGE HEATER

The two controls at the right top of the heater govern the input and output functions of the storage heater. Both are printed with the numbers 1 to 5.

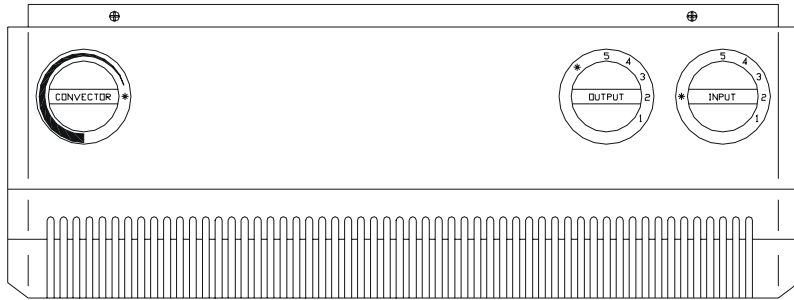

fig 5

The input control allows you to select the amount of heat you wish to store during the night.

During mild weather, it is normal to set your input control in a medium position. In cooler weather, the control could be set at 5 to give maximum heat retention.

The stored heat will be delivered to the room by both radiant and convected methods. The convected heat can be regulated by using the output control. This control governs the continuous flow of convected heat from the outlet grill.

All combined storage heaters have an exclusive feature which makes it unnecessary to close the output control at night. The outlet grill will close automatically at the beginning of the overnight charge

## USING THE CONVECTOR

Switch on the convector by setting the switch placed at the lower left side of the heater marked  to “-“.

The off position is marked “0”.

When the convector is generating heat, the neon indicator on the switch will be illuminated.

The convector is fitted with an adjustable thermostat, which enables room temperature to be controlled by adjusting the setting accordingly when the convector is on.

Turn the thermostat control to the maximum (fully clockwise) and when the desired temperature has been reached, turn the thermostat slowly to the left (anti-clockwise) until the luminous indicator switches off.

## INTRODUCTION

Storage heaters are designed to take advantage of the considerable economical benefits of any restricted hour electricity tariff. These heaters consume electricity only during the night, but due to the highly efficient storage medium, give you a truly economical 24 hours of comfort temperatures.

Model	Voltage V	Input kW	Convector kW	Max. Hours on	Charge kWh	Bricks	Weight kg	L cm	W cm	H cm
CSH12	230/240	1.6/1.7	0.9/1.0	8 / 7	12.8 / 11.9	8	80	54	18.5	73
CSH18	230/240	2.4/2.55	1.4/1.5	8 / 7	19.2/17.85	12	117	76.5	18.5	73
CSH24	230/240	3.2/3.4	1.6/1.75	8 / 7	25.6/23.8	16	154	99	18.5	73
CSH12A	230/240	1.6/1.7	0.9/1.0	8 / 7	12.8 / 11.9	8	80	54	18.5	73
CSH18A	230/240	2.4/2.55	1.4/1.5	8 / 7	19.2/17.85	12	117	76.5	18.5	73
CSH24A	230/240	3.2/3.4	1.6/1.75	8 / 7	25.6/23.8	16	154	99	18.5	73

The input control operates a highly sensitive thermostat which regulates the amount of heat stored.

The discharge is by convection heat which can be partially controlled by use of the output control. It is important that the correct rating of heater is installed to provide the selected level of heat. This will ensure the best possible running costs against other fuels.

To reduce transport problems, the heater casings and storage bricks are packed separately. The bricks are packed in sets of two.

You should be aware that Storage heaters, when fully charged, can have high surface temperatures.

## INSTALLING THE COMBINED STORAGE HEATER

1.- Chose the right place to install the heater. It is necessary that a minimum clearance of 50 cm is allowed to ensure the best heating results. Always maintain a minimum clearance of 50 cm from the heater to any combustible materials such as furniture and curtains.

2.- Open the carton at the indicated side and fix the feet (fig 1) without removing the heater casing). The screws are in the accessories bag. Turn the carton upside down to allow the heater to stand on its feet and remove the carton. Check that it is the correct model and that it is in good condition.

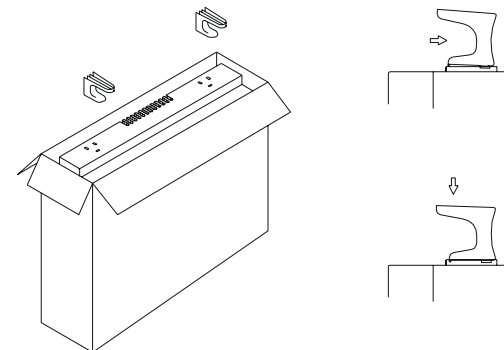

Fig.1