

LIP16715

## Lightweight, heavy duty inspection pit



The lightweight, heavy duty inspection pit with its unique design has resulted in performance capabilities superior to the traditional concrete pit, at a similar cost. Manufactured from a high performance polymer, the lightweight, heavy duty inspection pit is UV stable and chemical resistant.

The lightweight pit weighs only 1.8 kg and yet is loadrated to an impressive 5,000 kg. It has a lockable lid and improved working area compared to the concrete inspection pit.

In addition, the features incorporated within its design ensure ease of storage, reduced transportation costs, ease of installation and ease of subsequent inspection and testing of the earth electrode system, therefore providing significant practical benefits to both installers and specifiers alike.



# Lightweight, heavy duty inspection pit

## Features and benefits

- **Lightweight construction**  
The earth pit weighs only 1.8 kg, in comparison with a massive 30 kg for a concrete pit.
- **High load-bearing capacity**  
Safe working load of 5,000 kg, superior to that of the traditional concrete pit.
- **Lockable jam free lid**  
Once installed the lid can be locked to prevent tampering with equipment. Once locked, the design of the lid is such that debris cannot become jammed between the lid and the surround.
- **Shatterproof material**  
The high performance polymer is significantly less brittle than concrete, reducing the likelihood of wastage due to breakages.
- **Stackable design**  
A built-in stacking facility ensures ease of storage and handling.
- **Chemical resistance**  
Resistant to most substances, including petrol, oil, diesel, bitumen and concrete.
- **UV Stability**  
UV additive minimizing the effects of direct sunlight.
- **Wide temperature applications**  
Capable of withstanding a wide range of temperatures.
- **Improved working area**  
A larger working area, with improved access, simplifies both initial installation and subsequent inspection. Central 70 mm diameter rod location hole This ensures that the Earth Rod is centrally positioned, simplifying earth clamp connection.
- **Screw retention facility**  
The stainless steel, rustproof screws may be snapped into the lid, preventing loss whilst in storage or on site. The screws may also be used to lift off the lid using special sockets.
- **Optional earth bar facility**  
An earth bar may be inserted in the pit to allow for multiple connections to the earth rod.
- **Quality guarantee**  
Fully compliant to BS EN 62305-3 and tested to IEC 62561-5 Heavy duty classification

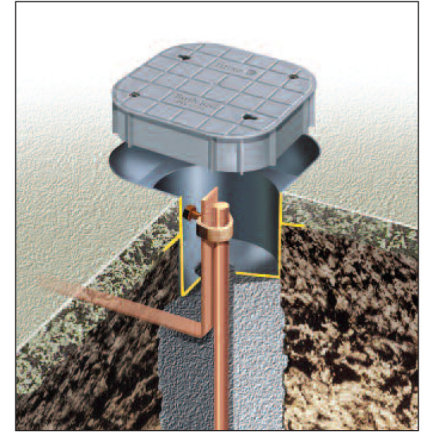

Recommended to be bedded in concrete. Installation instructions are incorporated on the side of the Inspection Pit base.

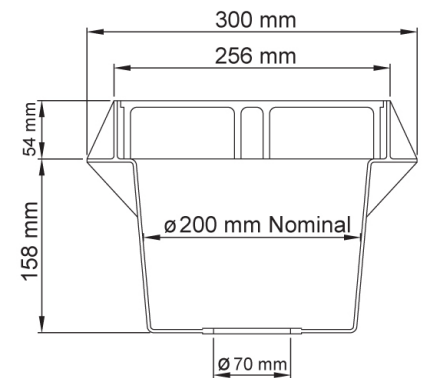

## Lightweight inspection pit

Part No.	Description	Weight each
PT205	Lightweight inspection pit with grey polymer lid	1.80 kg
PT209	Lightweight inspection pit with grey (unbranded) polymer lid	1.80 kg
PT004	Lightweight inspection pit with black (unbranded) polymer lid	1.80 kg
PT309-FU	5 hole earth bar	0.40 kg
<b>Accessories</b>		
AK005	6 mm Allen key	0.03 kg

# Contact us

## **ABB Furse**

### **UK Office**

Wilford Road  
Nottingham  
NG2 1EB

Tel: +44 (0) 115 964 3700  
Fax: +44 (0) 115 986 0071  
Sales Tel: +44 (0) 333 999 9900  
Sales Fax: +44 (0) 333 999 9901  
E-Mail: [enquiry@furse.com](mailto:enquiry@furse.com)

## **Thomas & Betts Ltd. Br.**

### **A Member of the ABB Group**

#### **Middle East Sales Office**

Office 724 6WA West Wing  
Dubai Airport Free Zone  
PO Box 54567  
Dubai

United Arab Emirates  
Tel: +971 (0)4 609 1635  
Fax: +971 (0)4 609 1636  
E-mail: [furseenquiry@tnb.com](mailto:furseenquiry@tnb.com)

## **Thomas & Betts (Saudi Arabia)**

### **KSA Office**

Building 128

Dammam Industrial Area #2

PO Box 514

Al Khobar 31952

Saudi Arabia

Tel: +966 13 812 1222

Fax: +966 13 812 1175

E-mail: [furseenquiry@tnb.com](mailto:furseenquiry@tnb.com)

## **Thomas & Betts Asia (Singapore) Pte Ltd.**

### **A Member of the ABB Group**

c/o ABB Pte Ltd

2 Ayer Rajah Crescent

Level 4

Singapore 139935

Tel: +65 6776 5711

Fax: +65 6778 0222

E-mail: [asia.inquiry@tnb.com](mailto:asia.inquiry@tnb.com)

[www.furse.com](http://www.furse.com)

**Note:** We reserve the right to make technical changes or modify the contents of this document without prior notice. With regard to purchase orders, the agreed particulars shall prevail. ABB AG does not accept any responsibility whatsoever for potential errors or possible lack of information in this document.

We reserve all rights in this document and in the subject matter and illustrations contained therein. Any reproduction, disclosure to third parties or utilization of its contents – in whole or in parts – is forbidden without prior written consent of ABB AG.

Copyright © 2015 ABB  
All rights reserved