

# Consumer Unit Design 30 Switch Disconnecter Incomer with SPD

For the distribution of power in a residential application, conforming to BS EN 61439-3 including Annex ZB (16kA rating).

Design 30 is the enhanced board for use in applications where the consumer unit is located in a living area of the dwelling.

The range of consumer units with a 100A rated current (InA) have been designed for installations where the upstream overcurrent protection device (OCPD) is rated at 100A or below.

Design 10 consumer unit is an entry level board designed for all applications and allows compliance with BS 7671:2018;

Regulation 421.1.201 within domestics (household) applications consumer units and similar assemblies shall comply with BS EN 61439-3 and shall have their enclosure manufactured from a non-combustible material.

Regulation 411.3.3 additional protection by means of a 30mA RCD is provided by RCBOs.

Regulation 314.1&2 segregation of circuits to avoid danger and minimise inconvenience in the event of a fault.

Regulation 522.6.202 protection of wiring concealed in walls or partitions.

Regulation 531.3.3 Selection of appropriate RCD. Type A RCBOs can detect and respond to both AC and pulsating DC components.

Regulation 536.4.3.2 & 536.4.202 overload protection of switches and RCCBs. For installations where the upstream overcurrent protection is less than or equal to 100 A.

Regulation 443.4 Protection against transient over voltages, provided by factory fitted type 2 SPD.

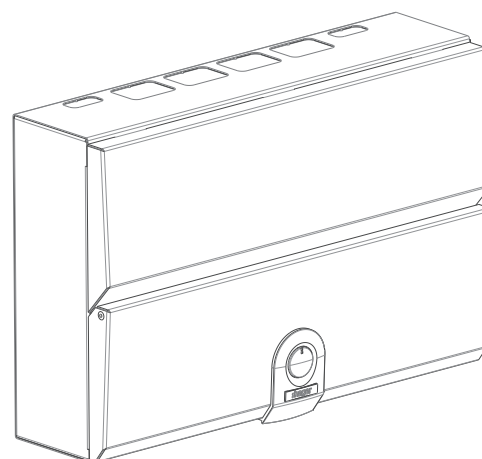

VM108SPD

Description	Size	Cat ref.	Cat ref. with Knockouts
8 Way 100A Switch Disconnecter Incomer with Factory Fitted SPD	4	VM108SPD	VM108KSPD
12 Way 100A Switch Disconnecter Incomer with Factory Fitted SPD	5	VM112SPD	VM112KSPD
18 Way 100A Switch Disconnecter Incomer with Factory Fitted SPD	7	VM118SPD	VM118KSPD
8 + 10 Way Dual Row 100A Switch Disconnecter Incomer with Factory Fitted SPD	4(2)	VM10810SPD	VM10810KSPD
12 +14 Way Dual Row 100A Switch Disconnecter Incomer with Factory Fitted SPD	5(2)	VM11214SPD	VM11214KSPD
16 + 20 Way Dual Row 100A Switch Disconnecter Incomer with Factory Fitted SPD	7(2)	VM11820SPD	VM11820KSPD

## Features & Benefits

- Cable clamp - Secures supply cables on entry to main incoming device preventing any movement being transmitted through metertails to device
- Square cable entry points top and bottom for use with cable trunking (references available with or without knockouts)
- Rear Knockouts for ease of cable entry – Cable protector plate provided
- Rigid top wall – Enhances rigidity to prevent distortion when removing knockouts
- Locate and hold cover - allows use of both hands whilst fixing cover
- Front cover retained screws – Prevents loss during installation
- Full metal DIN rail – Secure and stable attachment of devices
- Quick release clip on MCB/RCBO – Allows removal of MCB/RCBO with busbar still in place
- Optimised cabling space – DIN rail position allows maximum cabling space
- Top mounted terminal rail makes the wiring of the neutral and earth connections neat and simple.
- Health and Safety lock allows the door to be secured with circuits isolated during construction (via accessory, see overleaf).
- Torque settings displayed inside front cover so they're easily accessible by the electrician.
- Lockable front door via an accessory (see overleaf).
- Factory fitted type 2 surge protection

### Technical Characteristics

Standards	BS EN 61439-3
Classification	Consumer Unit
Rated & Operational Voltage ( $U_N/U_e$ )	230V a.c 50 Hz
Rated Insulation Voltage ( $U_i$ )	320V a.c. 50Hz
Rated Frequency (fn)	50 Hz
Rated impulse withstand voltage ( $U_{imp}$ )	4kV
Rated Current of the Assembly ( $I_{na}$ )	63A/100A
Rated Current of an Outgoing Circuit $I_{nC}$	RCBO <b>ADA1**G</b> - 40A - 45A (Marked Rated Current on Device) RCBO <b>ADA3**G</b> - 6A - 32A (Marked Rated Current on Device)
Rated Conditional Short Circuit of the Assembly ( $I_{CC}$ )	Annex ZB: 16kA rms at 250V, power factor 0.6 with equipment and arrangements specified in Hager's technical documentation/catalogue
Protection against electric shock	Consumer Unit shall be installed in an electrical system conforming to IEC 60364 / BS 7671
Rated Diversity Factor (RDF) / Values of assumed loading	2 Way to 3 Way - 0.8, 4 Way to 5 Way - 0.7, 6 Way to 9 Way - 0.6, 10 Way and above - 0.5

Note: RDF only applies to continuously and simultaneously loaded circuits. In principle, this means adjacent circuit breakers having a load on time exceeding 30 minutes or where a load not exceeding 30 minutes has an 'off' time less than the 'on' time will need to have the rated diversity factor applied as indicated.

Pollution Degree	2
Types of System Earthing for which the assembly is designed	TT, TNC-S and TN-S when installed in an electrical system conforming to BS 7671
Intended locations	Indoor use only
Stationary assembly	
Degree of protection	IP2XC with door open / closed and full compliment of devices / blanks fitted. Note: Where cables are installed through the top wall of the enclosure, gaps of IP4X to be maintained.
Intended use	Intended for use in domestic (residential) or similar premises
Electromagnetic compatibility (EMC) classification	EMC environment B
External design	Wall mounted, surface type, enclosed assembly.
Mechanical impact protection	IK05
Type of construction	Fixed parts
Incoming Line/Neutral terminal (80 - 100A board)	50mm <sup>2</sup>
Incoming Line/Neutral terminal (63A board)	25mm <sup>2</sup>
Incoming Earth Terminal	16mm <sup>2</sup>

Warranty - Hager undertakes to replace or repair at its discretion products should they become inoperable within the time periods as stated. - 2 Years

### Accessories

Cable protector plate	Provides protection for cables entering from the rear of the board	<b>VM02CE</b>
Health and safety lock	Provides the ability to lock the consumer unit during the installation process	<b>VMHBL</b>
Design 30 door locking kit	Allows the board to be lockable	<b>VMLOCK</b>
Grommet strip	For protecting cables against damage when entering the board	<b>VM05GS</b>
Rear stand off plates	To stand consumer unit off wall allowing surface mounted cables to enter through rear of unit.	<b>VM01SP</b>

### Devices

Single Pole, Single Mod RCBO 6kA, 40A - 45A Type A	<b>ADA1**G</b>
Single Pole, Single Mod Reduced Height RCBO 6kA, 6A - 32A Type A	<b>ADA3**G</b>

### Design 30 Dimensions (mm)

	Enclosure Size		
	4	5	7
Height	240	240	240
Width	293	364	472
Depth	102.5	102.5	102.5

	Number of Knockouts		
	4	5	7
<input type="checkbox"/> *Top Face 30 x 25 (mm)	2	2	2
<input type="checkbox"/> *Top Face 40 x 30 (mm)	4	4	6
<input type="checkbox"/> Back 100 x 50 (mm)	1	3	3
<input type="checkbox"/> *Bottom Face 30 x 25 (mm)	4	4	5

\* References with a 'K' suffix feature top and bottom square knockouts.

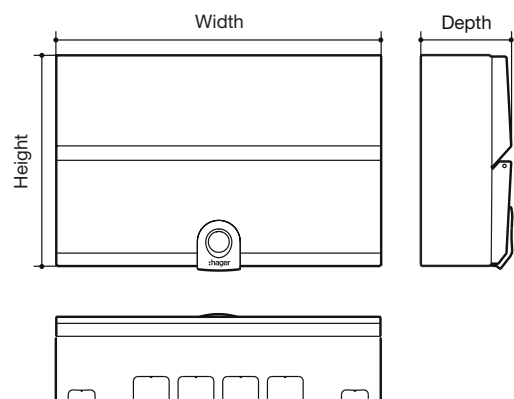

**Surge protection devices**

Consumer units with SPD in the part reference come with a Type 2 (T2) surge protection device. All connections to and from the surge protection device are made at the factory. The phase is protected by a Metal Oxide Varistor (MOV) and the neutral by a spark gap device. The Metal Oxide Varistor will degrade each time it deals with high voltage or electromagnetic disturbances, when it is end of life the flag will turn red and the cartridge will require to be changed. At this point the cartridge will fail open circuit and the device will no longer provide surge protection. Simply remove the cartridge and replace with a new cartridge (SPD015D). The rest of the installation will remain unaffected.

**To remove a cartridge when the flag is red**

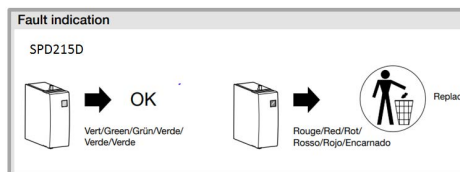
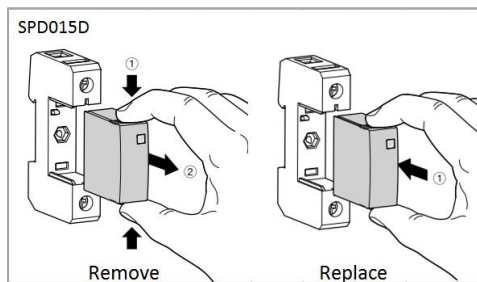

**Position of SPD in installation**

TT/ TN-S/ TNC-S

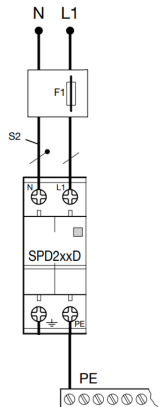

Overcurrent protection (F1) is provided by the upstream over current protection device (OCPD) which for a consumer unit is generally the service cut-out fuse.

**SPD Characteristics**

	$I_n$ (8/20 $\mu$ s)	$I_{max}$ (8/20 $\mu$ s)	$U_p$	$U_c$	F1 max $\ominus$	$I_{pe}$	$I_{scrr}$	
SPD215D	5 kA	15 kA	$\leq 1$ kV	275 V (50/60 Hz)	125 A gG	$< 5 \mu$ A	10 kA <sub>rms</sub>	SPD015D