

air pump

Two high performance reliable air pumps for large fish and koi ponds

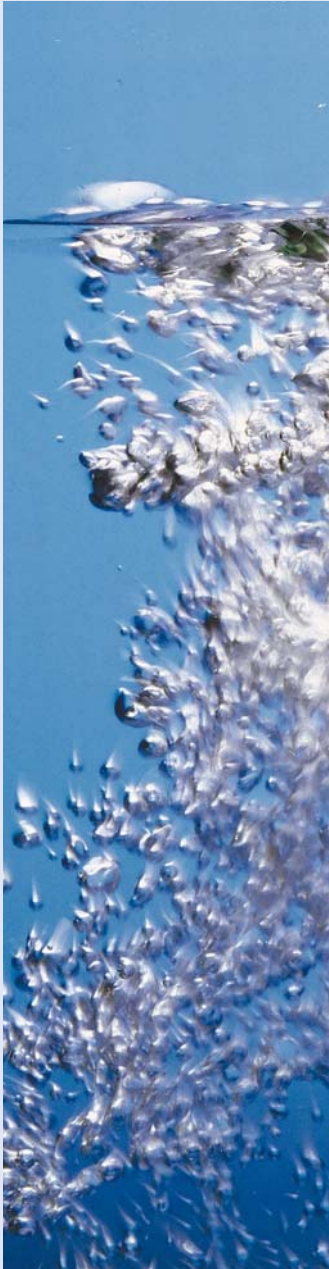

Adding oxygen into a fishpond is very important for fish health, particularly in densely stocked ponds and in the summer months when oxygen levels decline.

The pumps can be safely left uncovered outdoors to simplify installation.

The smaller model delivers 45 litres per minute and 35 lpm at a depth of 1m. The larger model delivers 75 litres per minute at a depth of 1m. Maximum operating depth 3m.

Both models are supplied with 100mm air stones, a chrome coated metal manifold with 12 outlets and air tubing (4mm Ø) as standard. The kit format makes the sales process quicker and easier for the consumer and retail staff.

The air stones produce maximum diffusion of the air into the water and avoids the need for multiple air stones making installation easier. Additional airstones can be added to provide oxygen to different areas the pond.

2-year guarantee.

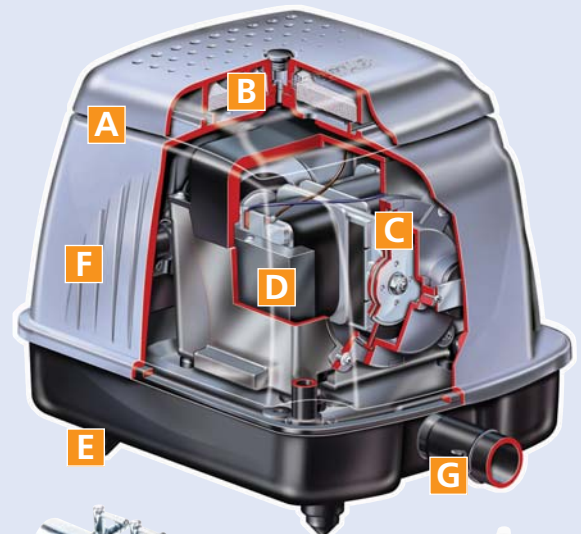

- A** Air inlet
- B** Air filter
- C** Robust diaphragm
- D** Quiet reliable low wattage motor with low running costs
- E** Rubber feet stop pump vibrating
- F** Stylish weatherproof aluminium cage
- G** Air output (45 /75 litres per minute depending on model)
- H** Chrome coated metal manifold with 12 outlets
- I** Air tube Ø 4mm ('Model 45' x 5m, 'Model 75' x 10m)
- J** 100mm sintered air stone Ø 5cm ('Model 45' x 1, 'Model 75' x 2)

Technical Data

Maximum Output (LPH)	Maximum Recommended Depth of Air Stone	Output at 1m Depth	Maximum Pressure	Number of Air Outlets	Length of Air Tube	Diameter of Air Tube	Size of Air Stone	Pump Rating	Cable Length
45LPH	2.0m	35LPM	0.030 MPa	12	5m	4mm	Ø 5cm x 10cm	35w	10m
75LPH	3.0m	45LPM	0.039 MPa	12	10m	4mm	2x Ø 5cm x 10cm	35w	10m

Part number	Description	Product Bar Code	Pack Qty
1820	Air Pump 45	50 10646 04339 7	2
1380	Air Pump 75	50 10646 04616 9	2
1821	Air Pump Spares Kit (45)	50 10646 04373 1	5
1377	Air Pump Spares Kit (75)	50 10646 04654 1	5