

SPECIAL EDITION

Evolution 150 Food Waste Disposer



The premium range of
food waste disposers



The special edition version of our quiet and powerful food waste disposer is specially built for large households and growing families. It stands out from the crowd and features a brand-new matte black trim shell and a premium stainless steel sink stopper with cover. The Evolution 150 is supplied with built-in air switches in matte black, chrome and brushed steel and is supported by a 7 year parts and service guarantee.



FEATURES

- Built-in air switch in matte black, chrome and brushed steel
- Compact design
- 7 year guarantee
- Evolution quiet technology
- Evolution 2-stage grind technology
- Auto-reverse grinding action
- High-torque Dura-Drive™ induction motor
- Stainless steel grind elements and grind chamber
- Overload protection
- Quick Lock® mounting assembly for faster, easier installation

**PRODUCT
SPEC SHEET**

Evolution 150
Food Waste Disposer

**S H O W R O O M
C O L L E C T I O N**

DIMENSIONS (mm)

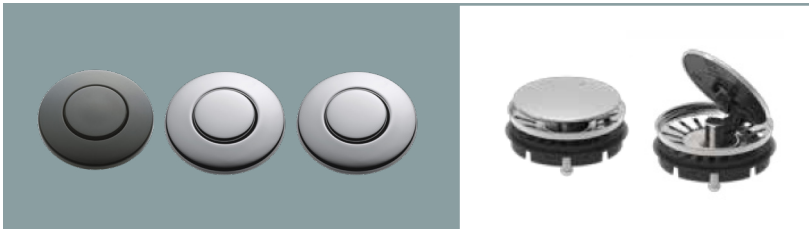
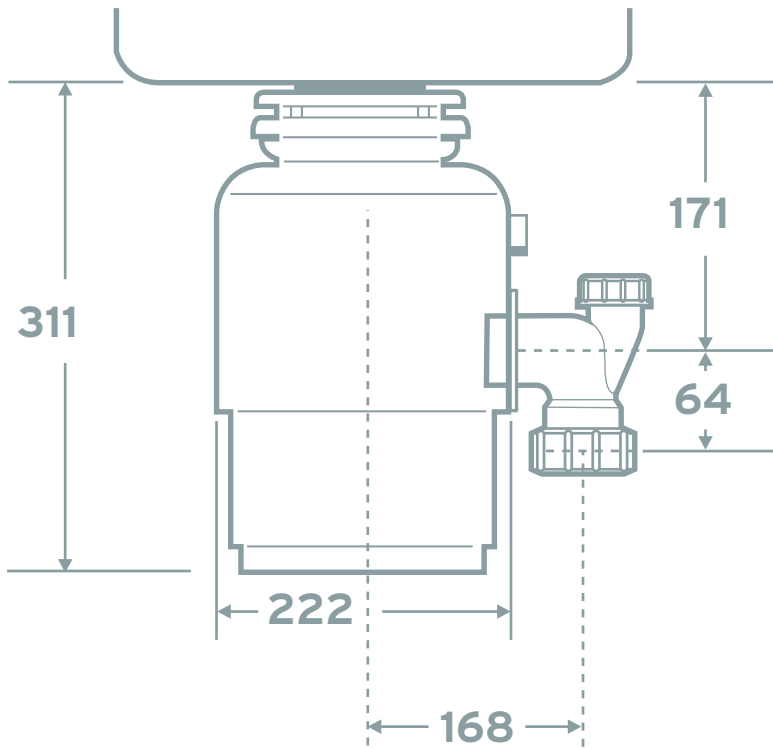

The Air Switch button is available in three colour choices.

Premium stainless steel stopper with cover.

For those who prefer the on/off switch built right into the disposer cover, InSinkErator offers the cover control accessory. It's just right for efficient batch feed operation.

SPECIFICATIONS

Type of feed	Continuous
On/Off Control	Wall switch or built-in air switch
Motor	Single phase
Reversing	Auto-reverse grind system
Time Rating	Intermittent
Lubrication	Permanently lubricated upper & lower bearings
Shipping Weight (Approx.)	10.0kg
Unit Finish	Black
Overall Height	311mm
Grind Technology	2-stage grind technology
Sound Technology	Anti-vibration mounting and Tailpipe Quiet Sink Baffle Multi layer sound insulation Stainless steel strainer basket & plug
Grind Chamber Capacity	1005ml
Motor Protection	Manual reset overload
Average Water Usage	Approximately 4.0L per person per day
Average Electrical Usage	3-4KWH per annum
Drain Connection	1-1/2" (3.81cm) Anti-Vibration (Hose Clamp)
Dishwasher Drain Connection	Yes

Volts/Hz	HP	RPM	Average load
220-240V, 50-60Hz	.75 (@240V/50Hz)	1425	380 W



InSinkErator. Suite 10, Building 6, Hatters Lane, Croxley Park, Watford, Herts WD18 8YH. United Kingdom

Sales tel: 01923 297 880
Service tel: 0800 389 3715
insinkerator.co.uk

