

SPECIAL EDITION

# Evolution 250 Food Waste Disposer



The premium range of  
food waste disposers



This special edition version of our quietest and most powerful food waste disposer stands out from the crowd. It features a new style trim shell and a premium stainless steel sink stopper with cover. It is supplied with built-in air switches in matte black, chrome and brushed steel and is supported by an 8 year parts and service guarantee.



## FEATURES

- Built-in air switch in matte black, chrome and brushed steel
- 8 year guarantee
- Deluxe polished chrome stopper cover
- New style trim shell
- Evolution Ultra-quiet technology
- Evolution 3-stage grind technology
- Auto-reverse grinding action
- High-torque Dura-Drive™ induction motor
- Stainless steel grind elements and grind chamber
- Overload protection
- Quick Lock® mounting assembly for faster, easier installation

**PRODUCT  
SPEC SHEET**

Evolution 250  
Food Waste Disposer

S H O W R O O M  
C O L L E C T I O N

**DIMENSIONS (mm)**

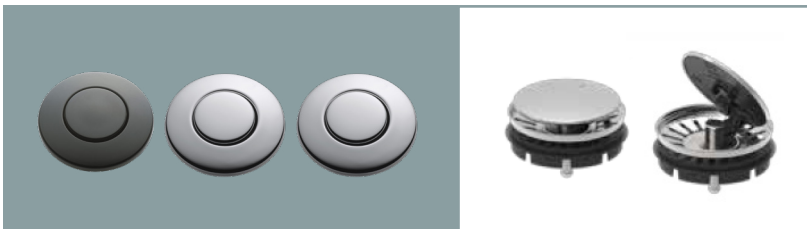
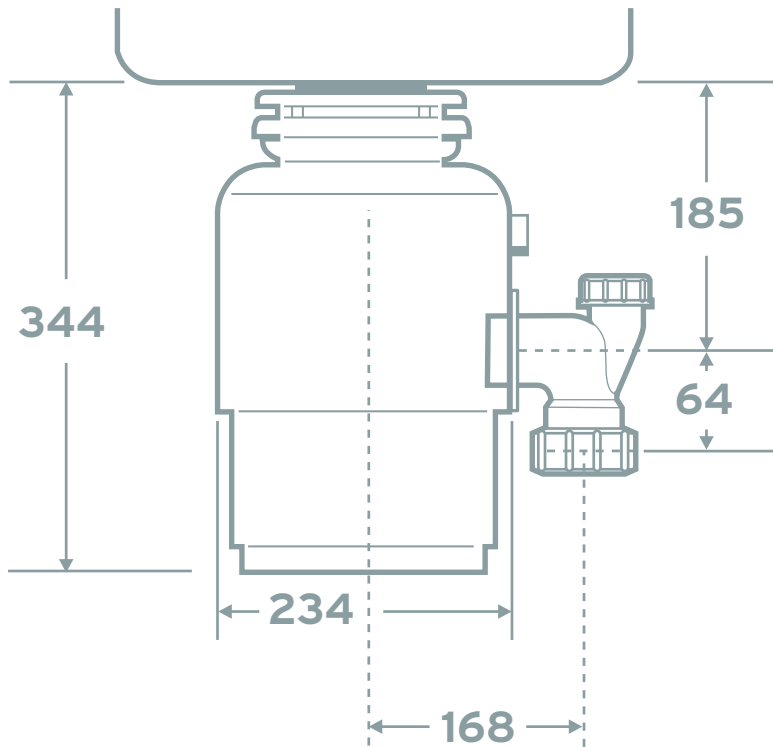

The Air Switch button is available in three colour choices.

Premium stainless steel stopper with cover.

For those who prefer the on/off switch built right into the disposer cover, InSinkErator offers the cover control accessory. It's just right for efficient batch feed operation.

**SPECIFICATIONS**

Type of feed	Continuous
On/Off Control	Wall switch or built-in air switch
Motor	Single phase
Reversing	Auto-reverse grind system
Time Rating	Intermittent
Lubrication	Permanently lubricated upper & lower bearings
Shipping Weight (Approx.)	11.6kg
Unit Finish	Stainless steel light grey TEN-1706
Overall Height	344mm
Grind Technology	3-stage grind technology Power booster circuit with microprocessor technology included
Sound Technology	Anti-vibration mounting and Tailpipe Quiet Sink Baffle Multi layer sound insulation Stainless steel strainer basket & plug
Grind Chamber Capacity	1180ml
Motor Protection	Manual reset overload
Average Water Usage	Approximately 4.0L per person per day
Average Electrical Usage	3-4KWH per annum
Drain Connection	1-1/2" (3.81cm) Anti-Vibration (Hose Clamp)
Dishwasher Drain Connection	Yes

Volt/Hz	HP	RPM	Average load
220-240V, 50Hz	.75	1425	380 W



InSinkErator. Suite 10, Building 6, Hatters Lane, Croxley Park, Watford, Herts WD18 8YH. United Kingdom

Sales tel: 01923 297 880  
Service tel: 0800 389 3715  
insinkerator.co.uk

