

## Hybrid9™

### JC99901

Interchangeable integrated LED downlight

Light source: LED Module  
 Total circuit Wattage: 8.5W  
 Lumens: 750 Lumens  
 Efficacy: 88 LpcW  
 Beam angle: 38°  
 Colour temp: 4000K  
 Ra: 80

### JC99903

Interchangeable integrated LED downlight

Light source: LED Module  
 Total circuit Wattage: 8.5W  
 Lumens: 725 Lumens  
 Efficacy: 85 LpcW  
 Beam angle: 38°  
 Colour temp: 3000K  
 Ra: 80

Available finishes: Brushed Nickel, Chrome & White

## Installation Sheet

Please read these instructions before installation and retain for future reference.  
 Check you have all the tools and accessories required to complete the installation correctly.  
 Isolate the power before starting the installation.

Fig.2

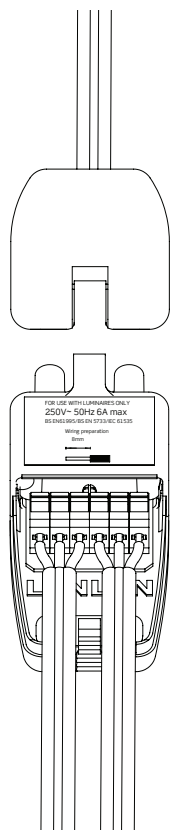

Fig.3

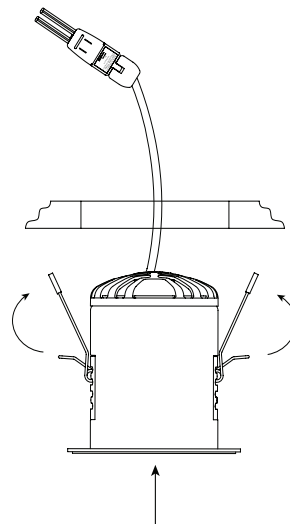
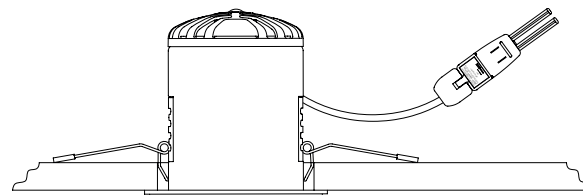

Fig.4



## Profile & Dimensions

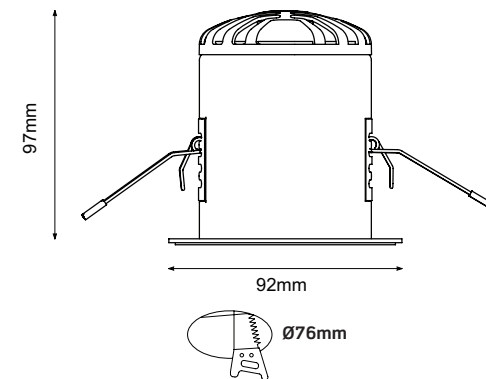

Fig.5a

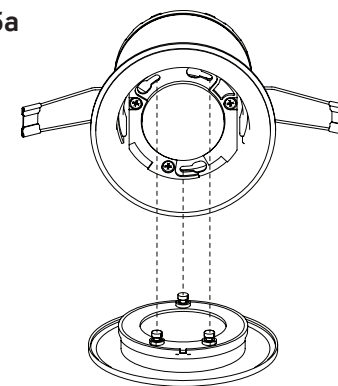
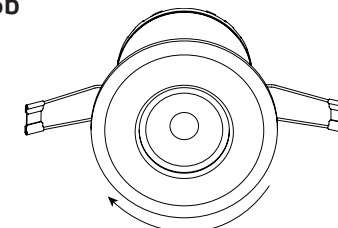

Fig.5b



## 220-240V~50/60Hz Class I

Fig.1. Class I products must always be earthed

mains loop in/out connection



LON LON

CE RoHS Compliant 0.3m IP65

BS EN ISO9001 - 2008

Registered Firm Certificate No. GB 1552

Drg No. JC99901-IS Issue: A - 17.01.17 - KB

1. Cut the mounting hole in the ceiling (Ø76mm). JCC recommends that a sample hole is cut in a section of spare material to familiarize yourself with the process.
2. The Hybrid9™ can be loosely covered with insulation. Ensure there is a minimum of 75mm space around the fitting. Refer to the good practice illustration on page 2 for guidance.
3. Connect the mains supply to the LEVLINK™ as per Fig.1. shown on the left.
4. Connect the LEVLINK™ female connector to the corresponding male connector on the luminaire as illustrated in Fig.2.
5. Turn on the power supply to test the fitting. Once satisfied that the luminaire is functioning correctly, press the spring clips against the side of the luminaire and fit into the aperture; as illustrated in Fig.3-4.

Please note: To remove bezel for decoration or replacement rotate bezel anti-clockwise. To re-attach module to fitting align pins as shown in Fig.5a and lock into place by twisting the bezel clockwise as shown in Fig.5b.

Hybrid9™ comes with an extended 10 year domestic warranty and a 5 year commercial warranty:

To register please visit [jcc.co.uk/warranty](http://jcc.co.uk/warranty). Prior to registration the installer is asked to provide the following information directly from the luminaire:  
 Product code & Batch number

For details of replacement modules please visit:  
[jcc.co.uk/hybrid9/module](http://jcc.co.uk/hybrid9/module)

**jcc.co.uk**

# Installation Recommendations

## Important Information

It is recommended that luminaires are installed and fitted by a qualified electrician ensuring the installation complies to current IEE wiring regulations and local building control. These products are designed for connection to a 220-240V~ 50/60Hz mains supply. This appliance will be considered Class I. Switch off the mains supply before installation or servicing. This product is for indoor use only. Ensure area surrounding this luminaire is cleared of any flammable substances. Where required by building regulations this product may be loosely covered with mineral wool insulation, however JCC recommends that there be adequate free air ventilation around the luminaire. **The light source must be a minimum distance of 0.3m from a lit object. The light source in this luminaire is replaceable: when the light source reaches its end of life the light source (module) can be replaced by the end user.** For details of replacement modules please contact JCC Technical or visit : [jcc.co.uk/hybrid9/module](http://jcc.co.uk/hybrid9/module)

## Part B Fire Safety

The purpose of Part B is to ensure building structures provide adequate protection to personnel to allow the safe evacuation of a building structure/complex. The regulation has been a legal requirement since 1987. All Hybrid9™ fittings are tested for 30, 60 & 90 minute ceilings (I Joist ceiling construction 30 & 60 minute compliant).

## Part C Resistance to Contaminants and Moisture

The amount of moisture that can enter a cold roof void must be controlled; thus anything which punctures the seal between the cold roof area and dwelling area must be considered. Light fittings are a good example of intrusions into the roof area that can facilitate the passage of moisture. Hybrid9™ downlights have been designed with special seals to inhibit the flow of air & moisture through the fitting as required by Part C of the building regulations.

## Part E Resistance to Sound

There is a general increase in the levels of background noise in a domestic environment. The Government has changed to the building regulations to ensure that reasonable noise attenuation can be expected between partition walls and ceilings not only between separate dwellings but also within individual residential area. The special gaskets incorporated into the Hybrid9™ design ensure that the criteria is met.

## Part L Conservation of Fuel and Power

The 2006 revision to Part L has focused lighting installations on energy conservation. There is now a need for 1 in 4 downlights to be energy efficient and have an efficiency of >45Lm/w.

## Cold Loft Spaces

To prevent accidental damage to the luminaire and to ensure good air flow around the fitting, JCC recommends the use of a 'Loft Brace'. This simple solution is designed to offer mechanical protection over the luminaire allowing all building and lighting standards to be met. The two halves of the Loft Brace are slotted together above the luminaire location as shown and fixed to the ceiling joists using screws (not supplied).

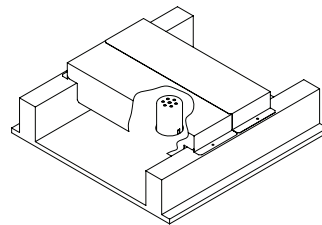

**JC94020** Loft Brace for 400mm joist spacing  
**JC94021** Loft Brace for 600mm joist spacing.

## Dimming Guidelines

Dimmers must not be underloaded or overloaded: underloading may cause the LEDs to flash. If flickering is experienced a different kind of dimmer may be required. Please note: DO NOT perform insulation resistance tests on a lighting circuit with LED lighting or a dimmer switch connected as this could damage the components in the products beyond repair. A slight buzzing noise may be heard from the dimmer switch while in operation, however this is perfectly normal. These notes are intended for guidance only. JCC Lighting accepts no responsibility for unsatisfactory installations or consequent loss or damage howsoever caused.

**Please Note:** These luminaires should not be installed on the same dimming circuit as FGLED10® or FGLED6® due to the dimming ratio; which may cause the LEDs to flicker. In all cases refer to dimmer switch manufacturers instructions. For a list of tested/approved dimmers please contact our technical support department or visit our website.

