

INSTALLATION & MAINTENANCE MANUAL
SWS01 Series



GENERAL INSTRUCTIONS

These instructions should be read carefully and retained after installation by the end user for future reference and maintenance.

These instructions should be used to aid installation of the following products:
SWS01W / SWS01C

SAFETY

- Installation of this product should only be carried out by a qualified electrician or competent person to the latest Building and current IEE Wiring Regulations (BS7671)
- Please isolate mains prior to installation/maintenance
- Check the total load on the circuit (including when this luminaire is fitted) does not exceed the rating of the circuit cable, fuse or circuit breaker
- Please note the IP (Ingress of Protection) rating of this product when deciding the location for installation
- Allow 50mm above and around the fitting for air dissipation (do not cover the fitting with insulation)
- This unit is rated at IP20
- This product is Class III

INSTALLATION

- Provide power to the required point of installation
- Cut a suitable hole in the surface as per the cut-out details (see Fig 1) ensuring not to infringe with any joists, gas/water pipes or electrical cables

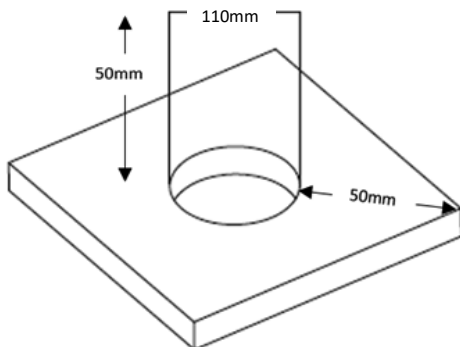

Fig 1

- Connect the MR16 lamp holder to the secondary side of the transformer or LED driver (transformer/driver not supplied)
- Connect the transformer or LED driver to the mains supply as per the manufacturer's instructions
- Place transformer or LED driver into the ceiling cavity
- Install the fitting into the cut-out (see Fig 2)

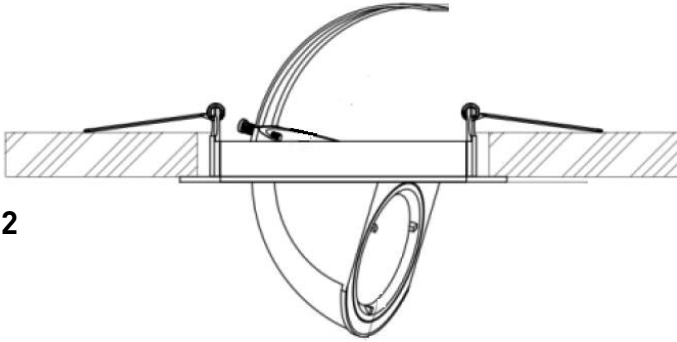

Fig 2

- Twist and remove the lamp retaining ring
- Install a retrofit 12V MR16 lamp into the retaining ring and plug the lamp into the lamp holder
- Refit the retaining ring and lamp into the fitting and twist to secure
- Switch on power supply and check for correct operation

WARNING

This product must be disconnected from the circuit if it subjected to any high voltage or insulation resistance testing. Irreparable damage will occur if this instruction is not followed.

GENERAL

The unit should be recycled in the correct manner when it reaches the end of its life. Check local authorities for where facilities exist. Clean with a soft dry cloth only, do not use aggressive cleaning products or solvents which may damage the product.

WARRANTY

This product has a warranty of 1 year from date of purchase. Failure to install this product in accordance with the current edition of the IEE Wiring Regulations, improper use, or removal of the batch codes will invalidate the warranty. If this product should fail within its warranty period it should be returned to the place of purchase for a free of charge replacement. ML Accessories does not accept responsibility for any installation costs associated with the replacement product. Your statutory rights are not affected. ML Accessories reserve the right to alter product specification without prior notice.

Knightsbridge[®]

the mark of quality



ML Accessories Limited
LU5 5TA
www.mlaccessories.co.uk

SBFEB18_V1