



21W GALAXY LED - GALAXY 21 IP54 DECORATIVE ROUND BULKHEAD

These instructions are in addition to the standard luminaire instructions that were supplied with the product you have purchased. Please read them carefully and install the luminaire as per instructions, then keep the instructions for future reference and maintenance.

IMPORTANT SAFETY INFORMATION

THIS PRODUCT MUST BE INSTALLED IN ACCORDANCE WITH ALL APPLICABLE INSTALLATION CODES.

INSTALLATION

1. The luminaire should be installed as instructed in the Instructions sheet supplied.
2. BE SURE POWER IS TURNED OFF AT THE MAIN POWER PANEL OR FUSE BOX PRIOR TO INSTALLATION OR REPLACING THE LUMINAIRE.
3. It is recommended that luminaires are installed by a qualified electrician ensuring the installation complies to current IEE wiring regulations & local building control.
4. This sensor is to be connected to a 230±10% volt, 50 or 60 Hz power source. Connecting to a different power source may create a hazard and will void the warranty.
5. Do not attempt to open the unit housing. There are no serviceable parts inside.
6. We will not accept responsibility for any claims arising from a poor installation.

TECHNICAL PARAMETERS

RATING	230±10% VAC 50/60Hz
STANDBY POWER	approx. 0.6W
MICROWAVE FREQUENCY	5.8GHz ± 75MHz CW RADAR, ISM BAND, TRANSMITTER POWER < 0.2mW
MOUNTING HEIGHT	2-3M (RECOMMEND 2.5M)
DETECTION ANGLE	360 DEGREES (CEILING MOUNTING)
DETECTION DISTANCE	Ø4-10m
AMBIENT CONTROL	10 Lux ~ ∞ (ADJUSTABLE)
TIME DELAY	1 ~ 30 MINUTES & TEST MODE
MANUAL OVERRIDE	4 HOURS
SWITCH TYPE	RELAY (LOAD CAPACITY: 10A, 277VAC)
OPERATING TEMPERATURE	0 ~ +60°C @ FULL LOAD; +70°C @ 60% LOAD
STORAGE TEMPERATURE	-20 ~ +80°C, 10-95% RH

MAXIMUM LOAD

INCANDESCENT	1000W
HALOGEN	500W
L.V. HALOGEN	200W
FLUORESCENT	400VA/cosφ=0.5 OR 160W/20uF Max.
ENERGY-SAVE LAMP	200W (CFL & PL)
LEDs LAMP	200W

High Environmental Adaptability

The microwave motion sensor has high reliability, it's detection range is less affected by temperature, wind, airflow, sound, light, fog, smoke, dust, etc.

High Sensitivity for Occupancy Detecting

This product can detect the slightest movement, such as lifting an arm, turning round, stooping etc. In addition, unlike infrared sensor, the microwave sensor has no directional characteristics. Movement in any direction can be detected.

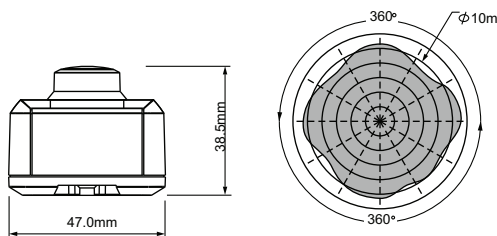
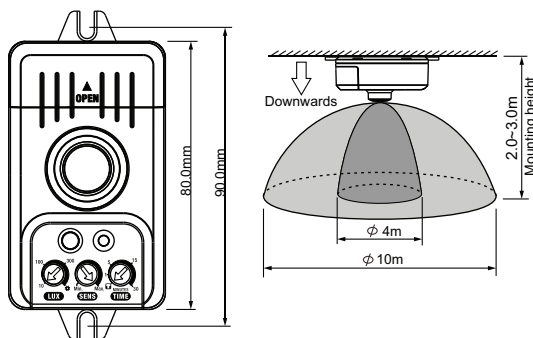

SETTING THE SENSOR

The sensor has three adjustments to control the fitting, which can be automatically turned ON or turned OFF according to setting value.

1. Ambient illumination detector (Photodiode)
2. Indicator (Red LED)
3. **LUX** Lux setting knob
4. **SENS** Sensitivity setting knob
5. **TIME** Time setting knob

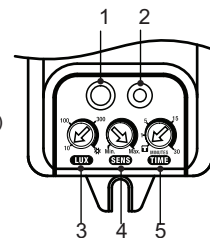

Time adjustment (1-30 Minutes & Test)

The TIME adjustment controls how long the fitting will stay on after motion is no longer detected.  is for test mode (see sensor status).

Sensitivity Adjustment

For minimum sensitivity turn the knob anticlockwise, for maximum sensitivity turn fully clockwise. Minimum sensitivity detects up to 4m. Maximum detection is up to 10m.

LUX Level

The LUX adjustment determines at what level the sensor will start operating when set to automatic operation & can be adjusted to suit individual requirements.

SENSOR STATUS

Warm-up: (LED indicator - ON; Loading - ON)

This unit requires a warm-up of approx. 30 seconds after power is applied for the system's circuit to stabilize.

Test Mode: (LED indicator - ON; Loading - ON)

Turn the time adjustment knob anticlockwise to the  position to enter test mode. Each time movement is detected the light will turn on for approx. 2 seconds then reset. Turn the knob clockwise to the required time to exit the test mode.

Stand-by: (LED indicator - OFF; Loading - OFF)

When the light level is above the required lux setting the sensor will go into stand-by.

Automatic Mode:

(LED indicator - Fast flash twice each detection; Loading - Auto ON/OFF)

When the timer is not in test mode & the lux level is adjusted, the sensor will go into automatic mode when the ambient light level is below the setting.

Manual Override:

(LED indicator - Interval 5 seconds flash 1 time; Loading - ON)

Turn the switch OFF then ON twice within 2 seconds. This will activate the manual override facility. The sensor will reset to automatic mode after 4 hours.

To return to automatic mode within the 4 hours turn the switch OFF then ON again within 2 seconds.

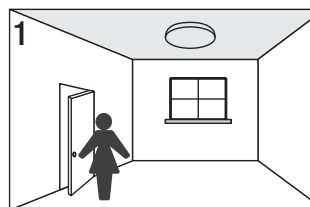

1 Sensor prevents activation during daylight hours.

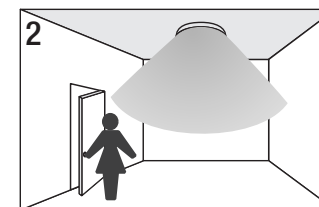

2 During darkness the sensor detects movement in the room and turns the light on.

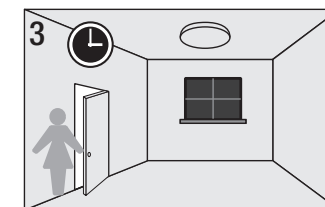

3 Once movement is no longer detected the sensor will turn the light off after the pre-set time.

TROUBLESHOOTING

Q1: Does not function at all

- Make sure the power switch (if applicable) is ON and check the wiring is correct.
- Check that the circuit breaker, fuse, and main circuit breaker or main power switch are ON.
- Check that the loading (such as light bulb) is functional.
- Should the light level be too bright it may be necessary to increase the LUX setting.

Q2: The sensor light is always ON

- The sensor may be in manual override mode. Turn the switch OFF then ON within 2 seconds to return to automatic mode.