

LTSPSSF2

Surface Mount Frame for Panel Light

The LTSPSSF Surface Mount Frame is designed for use with 600 x 600mm Ledlite Slim Panel Lights. Providing a practical solution for installations where recessed mounting is not possible. With a slim 25 mm profile, it offers a clean, low-profile finish ideal for modern commercial and residential environments. Constructed from robust aluminium with a smooth white powder-coated finish the frame ensures durability and seamless integration with ceiling aesthetics. It allows for easy installation of panel lights without requiring ceiling void access. Applications: Offices and meeting rooms, retail spaces, residential spaces with solid ceilings, schools etc.

Features & Benefits:

- 25 mm depth – slim and contemporary appearance
- Ideal for ceilings without accessible void or grid
- Aluminium construction for strength and stability
- Push-in corners for simple assembly

Dimensions:

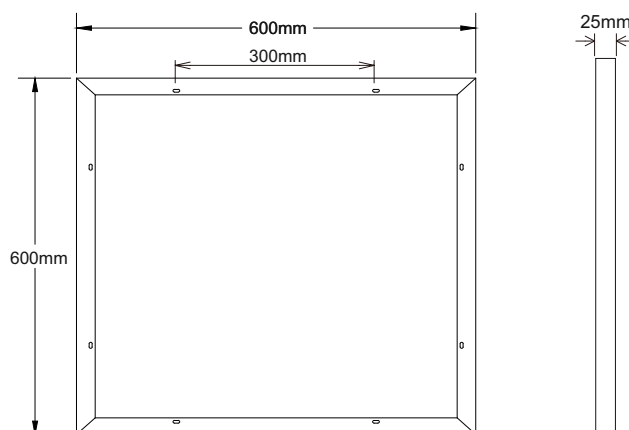

Technical Specifications:

| | |
|---------------------------------|-------------------------|
| Product Type: | Surface mounted frame |
| Compatible panel size: | 600x600mm |
| Depth: | 25mm |
| Material: | Aluminium |
| Finish: | White |
| Mounting Type: | Surface ceiling-mounted |
| Compatible Panel Lights: | LTSP40 |