

Congratulations on the purchase of your high gain digital aerial. The aerial is ideal for the reception of all available signals in medium, weak and fringe areas.

The aerial has also been designed to restrict bandwidth to prevent interference & channel loss on TVs caused by signals from 4G mobile phone transmitters.

The aerial is of particularly robust construction to ensure a long operating life.

- Ideal for fringe reception areas
- Tilting mast clamp for easy adjustment
- Easy dipole assembly
- Unique compact folding design
- Frequency: 470 - 790MHz
- Forward Gain: 14.5dBi
- Length: 1100mm
- Electronic 75Ω balun
- Connection: F type

Installation Instructions

For optimum results install the aerial using double screened CAI approved digital coax cable and screened coax outlets. You will need to fit the coax cable with an F type connector to connect to the aerial balun.

1. Prepare the Coax Cable: Firstly fit the rubber weather boot provided, to the aerial end of the cable. Strip the end of the cable as shown in Fig. 1. Once you have stripped the cable, twist the braid and pull it back on itself, make sure that no braid is touching the copper core, this will cause a short on the cable and you will not get any signal.

2. Fitting the F connector (not supplied): Now, simply twist on an 'F' connector and trim central conductor.

For best results the aerial should be mounted on an outdoor aerial mast and pointed in the direction of the nearest transmitter* making sure it is in a position where the transmitter signal will not be obstructed by nearby trees and buildings. If you are in any doubt about the direction in which the aerial should be pointing or the orientation of the aerial (horizontal for main transmitter, vertical for relay transmitter) check your neighbours' aerials.

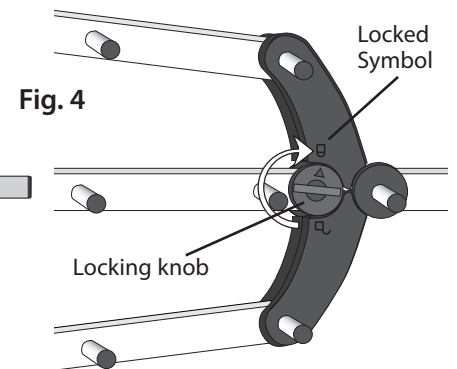
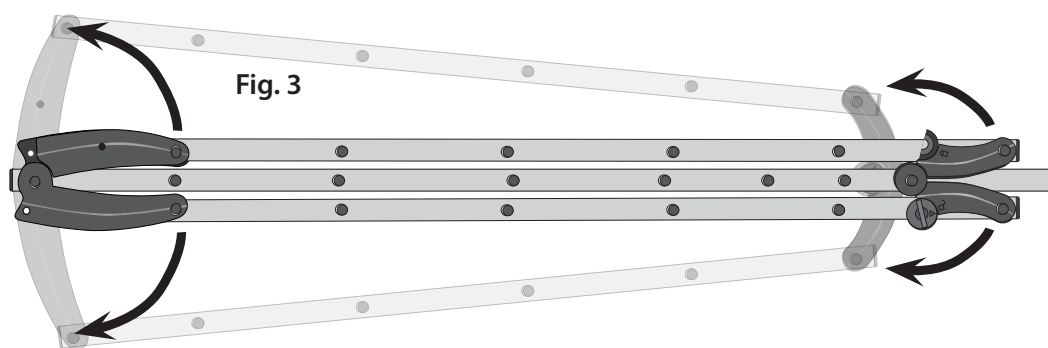
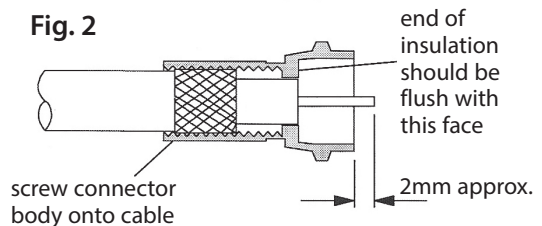
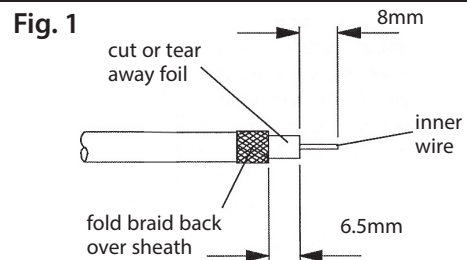

3. Unfold the booms as shown above. To lock the booms in position turn both of the two knobs on either side of the aerial in a clockwise direction through 180° making sure that the arrows line up with the locked symbol - see Fig. 4.

4. Next fasten the balun to the underside of the main central boom as shown in Fig. 5. Make sure the balun is the right way round with the locating stud slotted into the locating hole on the underneath of the central boom.

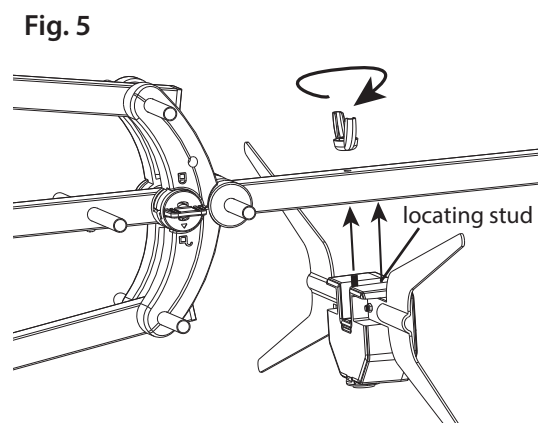

- The reflector bracket rotates through 90°. When boxed it is usually in the horizontal position as it takes up less space. Before attaching the reflectors the bracket must be rotated into the vertical position as shown in Fig. 6. If you need to rotate the bracket push it towards the front of the aerial to unlock, then rotate clockwise through 90° using the arrow as a guide then pull the bracket back into its original position.*
- Slide the reflectors into the reflector bracket until the locating studs click into place as shown in Fig. 6.*
- Use the tilting mast clamp supplied to fix the aerial securely to the mast. Adjust the tilt angle to make sure the aerial is horizontal, see Fig. 7 and 8.
- Connect the aerial downlead to the 'F' socket on the aerial balun (be careful not to over tighten the F connector as this will damage the balun). Ensure that the weather boot is correctly secured over the 'F' connector and socket - see Fig. 9. Make sure that the coax cable is routed as shown in Fig. 9 (through the middle of the lower reflector). Use insulating tape, to secure the the coax downlead to the reflector and mast.
- Fine adjust the tilt and direction of the mast clamp to tune for optimum reception.

*Please note that when the reflector locating studs have clicked into place the reflector bracket is locked into position. If you are unable to push the reflectors in completely to locate the studs make sure the bracket has been pulled right back.

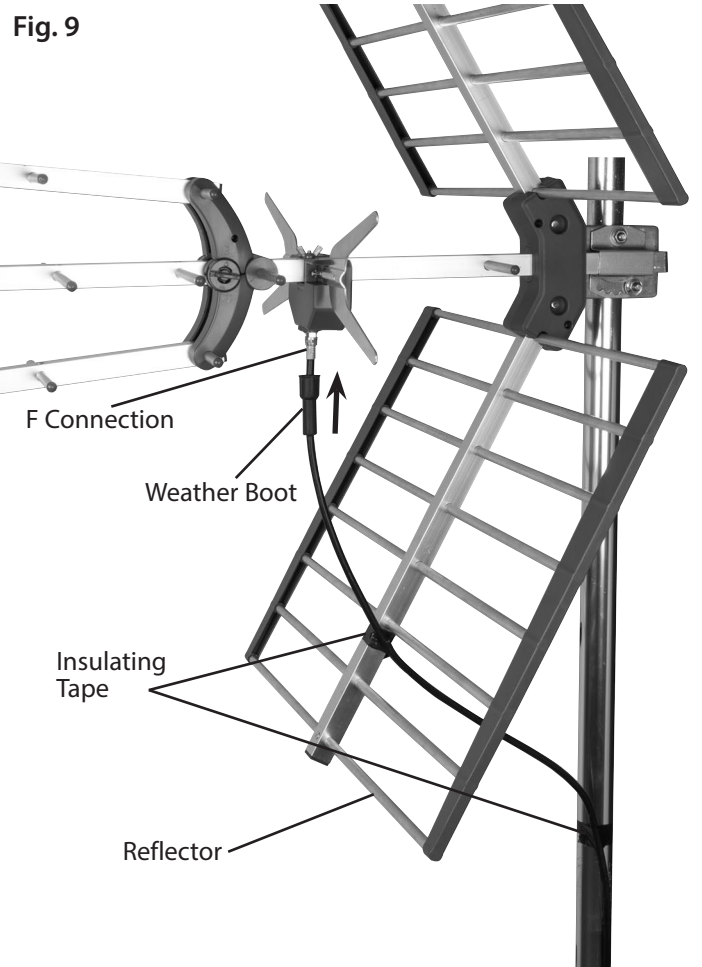
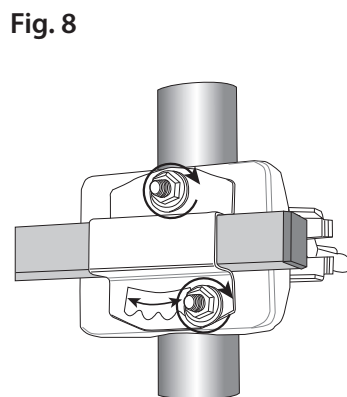
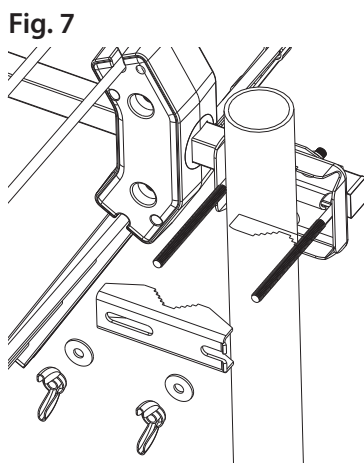
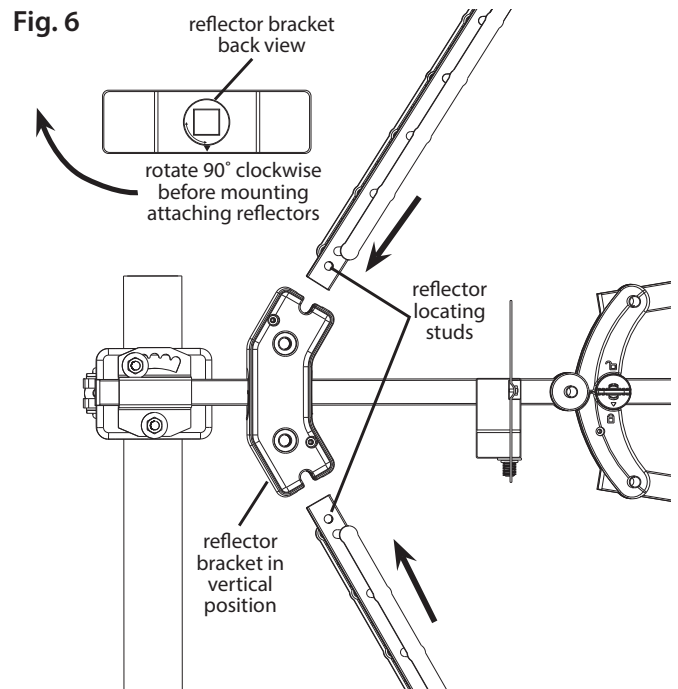

Troubleshooting

No picture: Check all connections from aerial to TV.

Poor picture: Check all connections from aerial to TV. Check aerial is properly aligned to the correct transmitter. If the aerial has been loft mounted try mounting outside. Make sure new digital coax cable has been used throughout the installation. Check the transmitter signal is not obstructed by nearby trees or buildings. If in a very weak signal area or for long cable runs, installing a masthead amplifier will improve the signal. If in a strong signal area the signal strength may need to be reduced by fitting an attenuator.

Caution

When mounting the assembled aerial, always observe safety precautions and use the correct equipment.

Unless you are competent in the use of ladders and other access equipment, do not work outdoors at roof height. If in any doubt, refer to a qualified aerial installer.

Specifications

Frequency Range:	470-790MHz
TV Channels:	21-60
Forward Gain:	12.3dBd
Forward Gain:	14.5dBi
Front/Back Ratio:	>16.0 dB
Beam Width:	+/-16°
PCB Balun:	Yes
Connector:	F-Type
Length:	1100mm
Width:	535mm

Useful Websites for Digital Advice:

*To find out which DTT channels should be available locally and to find out where your nearest transmitter is visit:
<http://www.digitaluk.co.uk/coveragechecker/>
 and enter postcode, house number if you also check the detailed view box you will see a list of transmitter's with distances and compass bearings.

For further information, please contact:
Customer careline: 08457 573479 (Local Rate - UK Only)
Technical Support: www.philex.com/support/



Waste electrical products should not be disposed of with household waste. Please recycle where facilities exist. Check with your Local Authority for recycling advice.

