

## Product selected: Dichroic EXN 50W/12V 38°

A contractor favourite, sealed front low voltage (12V) halogen lamp with dichroic reflector and sealed flat front lens, offering outstanding performance and reliability.

### Applications

- Accent and decorative lighting in retail, commercial and domestic applications
- Professional lighting of objects and displays, sensitive to heat

### Features

- Sealed, flat front, lens protects capsule and reflector from dust, and offers extra safety
- Cool Beam - 66% of the heat produced is radiated through the back of the lamp
- Dimmable using a suitable dimmer for operation with a transformer
- Constant colour and light output throughout lamp life
- Excellent colour rendering
- Burning position: universal
- The use of UV-Stop materials dramatically reduces UV emissions
- Average rated life: 4000 hours

### Directions for use

- Diamond Dichroic lamps must only be used in fixtures that are designed for use with Cool Beam lamps and which will dissipate the heat radiated from the back of the lamp
- Do not exceed the maximum power rating stated on the fixture
- Do not use the lamp in fittings marked with this label:

### Product Attributes

Item description	Dichroic EXN 50W/12V 38°
Ordering Code	0021767
EAN code	5410288217673
Packing Quantity	100
Wattage (W)	50
Voltage (V)	12
Cap	GX/GU5.3
Max. Over. Length (mm)	45
Diameter (mm)	51
Average life (hours)	4000
Colour Temp (K)	3050
Beam angle(°)	38
Peak intensity (CD)	1950

### Product Image



### UV Stop

**UV STOP**

### Illuminance Diagram

## Dichroic - 50W/38°

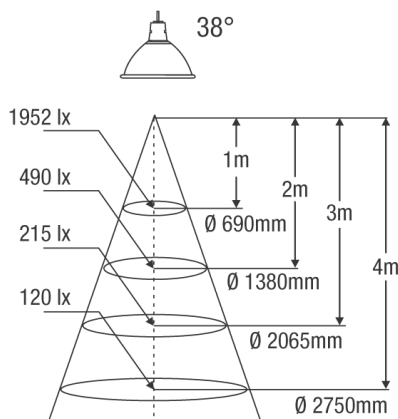

### Line Drawing

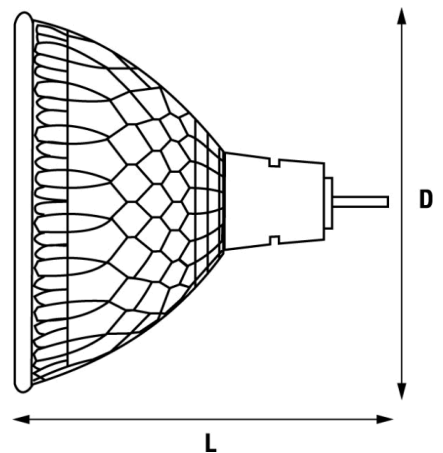

### Lamp Cap

