

Cleaning:

- > Clean this sign only with a soft dry cloth—Do not use any chemical or abrasive cleaners.

Lamp replacement:

- > The light source in your exit sign is a bespoke array of LEDs. These LEDs have a life expectancy of many tens of thousands of hours and so are unlikely to need replacing.
- > If one or more of the LEDs do not light, the strip of LEDs will need to be replaced. Contact the helpline below for more information.
- > To fit: remove battery cover and the end cheek with the button and indicator LEDs (see inside) taking care not to damage cables connected to the rear.
- > Pull plugs from sockets on both ends of LED strip.
- > Using a long nose plier or similar tool, carefully pull the LED strip out of the fitting noting which socket corresponds to which end of the fitting.
- > Insert replacement strip.
- > Reconnect both plugs.
- > Replace battery cover and end cheek.
- > Restore the power and switch on.

Battery replacement:

If after routine operation check, the sign does not remain lit for the prescribed period, a new battery pack may be required.

- 1) Switch off the electricity at the mains.
- 2) Allow batteries to fully discharge then reconnect to supply and allow to charge for 24 hours.
- 3) Test again for 3 hours, if light does not remain lit change the battery pack as follows:
- 4) Remove the battery cover—see fig.1&2 inside.
- 5) Unplug the battery lead from the circuit board.
- 6) Pull the battery pack out of the fitting.
- 7) Write current date on the new battery pack.
- 8) Slide the new battery pack into the fitting.
- 9) Plug battery pack into circuit board.
- 10) Close and secure the battery cover.
- 11) Restore power and allow to charge for 24 hours.
- 12) Perform full operation check and update test record.

Replacement battery type:

3 x 2/3 AA, 3.6V, 600mAh NiCD

Eventually, you may want to replace this exit sign:

When your exit sign comes to the end of its life or you choose to update or upgrade it by replacing it, please do not dispose of it with your normal household waste, please recycle where facilities exist. When you need to dispose of this fitting, check with your retailer or local authority for suitable options. New regulations require the recycling of Waste from Electrical and Electronic Equipment (European "WEEE Directive" effective August 2005—UK WEEE Regulations effective 2nd January 2007). Environment Agency Registered Producer: WEE/GA0248QZ



If you experience problems:

If your light is defective or develops a fault, please return it to the place where you bought it. You can call our Helpline for advice. The Helpline will gladly give advice on any aspect of any Eterna Lighting product but may not be able to give specific instructions regarding individual installations.

If in doubt, consult a qualified electrician.

Help line:

Tel: 01933 673 144 Fax: 01933 678 083 Email: sales@eterna-lighting.co.uk

For answers to frequently asked questions (FAQs) and other information visit our web-site

www.eterna-lighting.co.uk



IMPORTANT!

Safety and Installation instructions

LED Edge-lit emergency exit sign

Model(s)
LEDESLS, LEDESLWH

Specification:

Power	3W
Continuous illumination	>3 hours
Battery	3 x 2/3AA 3.6V 600mAh NiCD
Recharge time	~24 hours
Over-discharge protection	Yes

**PLEASE READ THESE INSTRUCTIONS BEFORE
INSTALLING YOUR NEW FITTING**

PLEASE RETAIN FOR FUTURE REFERENCE

Read this first:

- > **This light fitting must be installed in accordance with the Building Regulations making reference to the Wiring Regulations BS7671.** The Building Regulations may be obtained from HMSO or viewed and downloaded from www.communities.gov.uk following the link for Building Regulations.
- > Switch off the mains before commencing installation and remove the appropriate circuit fuse.
- > Your emergency fittings should have their own separate mains supply circuit and should not share their supply with other lighting or electrical devices.
- > Suitable for indoor use only.
- > Disconnect the product from the electrical supply before flash or high voltage testing.
- > This product is suitable for installation on flammable surfaces (indicated by the "F" in a triangle)
- > Before making fixing hole(s), check that there are no obstructions hidden beneath the mounting surface such as pipes or cables.
- > The chosen location of your new fitting should allow for the product to be securely mounted (e.g. to a ceiling joist) and safely connected to the mains supply (lighting circuit).
- > Ensure that the fitting will be accessible after installation for maintenance.
- > If the location of your new fitting requires the provision of a new electrical supply, the supply must conform with the requirements of the Building Regulations making reference to the Wiring Regulations (see above).
- > Make connections to the electrical supply in accordance with the following code:
 - Live - Brown or Red
 - Neutral - Blue or Black
 - Earth - Green and Yellow
- > This product must be connected to Earth.
- > The ballast/ PCB inside this luminaire is only for use in this luminaire and should not be

used in any other way.

- > You are advised at every stage of your installation to double-check any electrical connections you have made. After you have completed your installation there are electrical tests that should be carried out: these tests are specified in the Wiring Regulations (BS7671) referred to in the Building Regulations. If in doubt, consult a qualified electrician.

Installation:

- 1) Undo the screws at each end of the ceiling box and lift off the top cover.
- 2) Remove the mains wires from the terminal block noting the position of each wire.
- 3) Use the rear of the case as a template, mark the position of the fixing holes on your mounting surface.
- 4) Thread your mains supply cable through the large hole in the rear of the case.
- 5) Secure the rear of the case to your mounting surface using suitable fixings (not supplied).
- 6) Secure the mains supply cables into the terminal block according to the colour code opposite and following the terminal identification marked next to the terminal block in the fitting.
- 7) Re-connect the wires from the fitting according to the colour code opposite and following the terminal identification markings in the fitting. Ensure that the wiring from the mains supply corresponds to the wires from the fitting.
- 8) Replace the ceiling box cover and secure using the two screws removed earlier.
- 9) Remove the battery cover and connect the battery pack. See fig. 1&2 opposite. Close the battery cover.
- 10) Restore the power supply.
- 11) The LED indicators should light to indicate correct charging and the sign panel will also light. The LEDs indicate the following function: P= mains power O.K., C= batteries charging O.K., T= fault.

To change the sign:

- 1) Undo the screw and remove the cover at the mains cable end of the fitting.
- 2) Gently pull the sign out of the body—take care not to lose the small steel pins fitted to the top of the panel.
- 3) Insert the new panel into the end of the body locating the first steel pin in the track in the bottom of the body.
- 4) Holding the panel at a slight angle, push the first steel pin along the track towards the end of the fitting.
- 5) When the sign is almost in place, locate the second pin in the track and press the sign into the fitting until it is central in the body.
- 6) Replace the cap and screw.

Operation checks:

Periodic testing should be carried out simulating failure of supply, causing the fitting to be energised from it's battery. Interruption of supply should be carried out by pressing the test button on the end of the fitting or by operation of a local keyswitch or other isolation device. During this period all fittings should be examined visually to ensure that they function correctly. At the end of the test period the supply shall be restored and all indicator lamps checked to ensure that the normal supply has been restored. The duration of the simulated failure shall be:-

> Each month:

Isolate the power supply and check the sign is illuminated. This test should last for no more than 45 minutes. Endorse the test record form supplied.

> Every six months:

Isolate the power supply and check that the sign is still illuminated after 1 hour. Endorse the test record form.

> Once each year:

Isolate the power supply and check that the sign is still illuminated after 3 hours. Endorse the test record form.

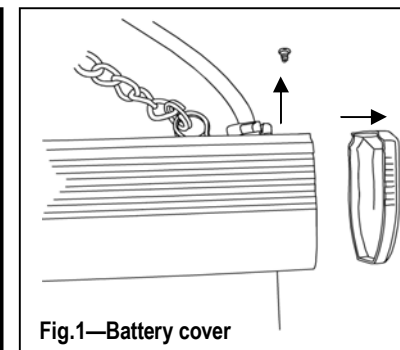

Fig.1—Battery cover

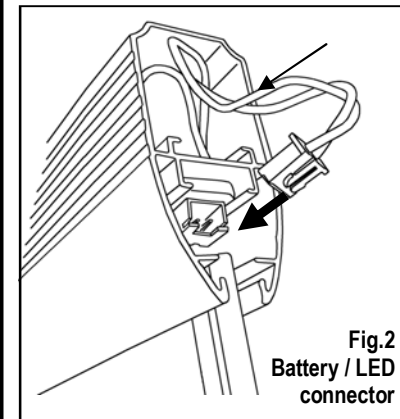

Fig.2
Battery / LED
connector

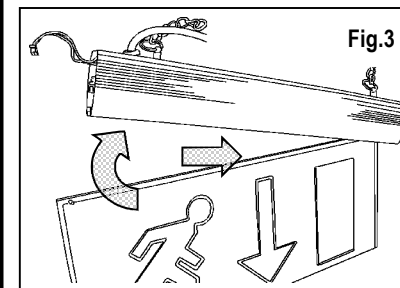

Fig.3

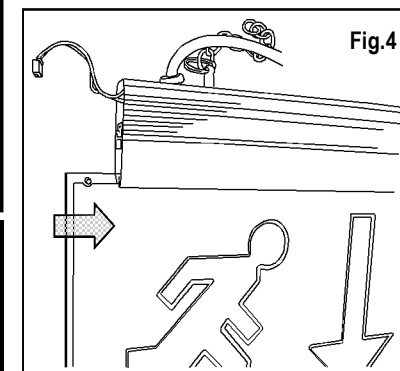

Fig.4

Safety markings:



Please keep this instruction booklet and test record in a safe place. A fire officer or other authorised person may want to see your record of inspection and testing.

