

Cleaning:

- > Disconnect the power and clean the exterior only of this fitting with a moist (not wet) cloth.
- > The diffuser may be removed and washed in a mild detergent solution. Make sure it is completely dry before putting it back on your light fitting.
- > Do not use any chemical or abrasive cleaners.

Lamp replacement:

- > Switch off the electricity at the mains.
- > Remove the diffuser etc., see diagram inside. Take care not to lose the small "O" ring seals fitted to the screws.
- > Remove and replace lamp. Note, the lamp pulls directly out of the lampholder, do not twist.
- > Replace the diffuser and trim (if fitted). Ensure that that all seals and gaskets are correctly positioned.

Replacement lamp type:

Wattage: 18 W
Supply Voltage: 240 V
Type: G24q base CFL—4 pin

Eventually, you may want to replace this light fitting:

When your light fitting comes to the end of its life or you choose to update or upgrade it by replacing it, please do not dispose of it with your normal household waste, please recycle where facilities exist. When you need to dispose of this fitting, check with your retailer or local authority for suitable options. New regulations require the recycling of Waste from Electrical and Electronic Equipment (European "WEEE Directive" effective August 2005—UK WEEE Regulations effective 2nd January 2007).



If you experience problems:

If your light is defective or develops a fault, please return it to the place where you bought it. You can call our Helpline for advice. The Helpline will gladly give advice on any aspect of any Eterna Lighting product but may not be able to give specific instructions regarding individual installations. If in doubt, consult a qualified electrician.

Help line:

Tel: 01933 673 144 Fax: 01933 678 083 Email: sales@eterna-lighting.co.uk
For answers to frequently asked questions (FAQs) and other information visit our web-site
www.eterna-lighting.co.uk



IMPORTANT !

Safety and Installation instructions

Low energy bricklight

Model(s)
B18WSS

Pack contents:

Bricklight fitting c/w trim	1
Cable gland	2
Screws	4
Plastic wall plugs	4
4 pin CFL	1

**PLEASE READ THESE INSTRUCTIONS BEFORE INSTALLING
YOUR NEW FITTING**

PLEASE RETAIN FOR FUTURE REFERENCE

Read this first:

- > This light fitting must be installed in accordance with the Building Regulations. These may be obtained from HMSO or viewed and downloaded from www.communities.gov.uk following the link for Building Regulations.
- > If in any doubt, consult a qualified electrician.
- > Disconnect the fitting from the electrical supply before flash or high voltage testing.
- > Suitable for indoor and outdoor use.
- > This product is suitable for installation on surfaces with normal flammability (indicated by the "F" in a triangle) e.g. wood, plasterboard, masonry. It is not suitable for use on highly flammable surfaces (e.g. polystyrene, textiles).
- > Before making fixing hole(s), check that there are no obstructions hidden beneath the mounting surface such as pipes or cables.
- > If the location of your new fitting requires the provision of a new electrical supply, the supply must conform with the requirements of the Building Regulations.
- > This product is designed for permanent connection to fixed wiring: this should be either a suitable lighting circuit (protected with a 5 or 6 Amp MCB or fuse) or a fused spur (with a 3 Amp fuse) via a fused connection unit. We recommend that the supply incorporates a switch for ease of operation.
- > Make connections to the electrical supply in accordance with the following code:
 - Live - Brown or Red
 - Neutral - Blue or Black
 - (Earth - Green and Yellow) *Note: this terminal is provided for looping through and is not required for the safety or operation of the fitting.*
- > This fitting is double insulated, do not connect any part to earth other than the looping through terminal as described above.
- > You are advised at every stage of your installation to double-check any electrical connections you have made. After you have completed your installation there are electrical tests that should be carried out: these tests are

specified in the Wiring Regulations (BS7671) referred to in the Building Regulations. If in doubt, consult a qualified electrician.

Installation:

- 1) Choose the location for your bricklight according to the conditions listed above. Your bricklight is designed to fit into the space occupied by one normal single housebrick.
- 2) Remove the stainless steel trim and diffuser. Take care not to lose any of the "O" ring seals on the screws.
- 3) Remove the lamp by pulling straight out of the lampholder—do not twist.
- 4) Loosen the screws either side of the lampholder and remove the two screws at the opposite end of the ballast case inside the fitting and slide it out.
- 5) Offer the remaining case into the cavity into which you want it to fit and mark the location of the fixing holes on your mounting surface.
- 6) Make the fixing holes as appropriate.
- 7) Remove the blank(s) from the cable entry(ies) using either a core drill or slow drill with large bit. The hole should be 16.0mm diameter.
- 8) Fit the cable gland(s) to the case as required. Thread the supply cable through the gland and into the fitting.
- 9) Make the electrical connections to the ballast according to the colour code above.
- 10) Slide the ballast case back into position and replace/tighten all four screws.
- 11) Ensure that the reflector sits correctly in the case.
- 12) Tighten the grip ring(s) on the cable gland(s).
- 13) Offer the case into the cavity once more and secure in position using the fixings supplied. If the fixings supplied are not appropriate to your installation, select suitable alternatives.
- 14) Re-fit the lamp, press firmly into the lampholder until it clicks into place.
- 15) Fit the diffuser onto the fitting and secure using the two screws on the longest sides (top and bottom). Ensure that the small rubber "O" ring gaskets are in place.
- 16) If you do not want to fit the stainless steel trim,

- insert the remaining two screws and tighten.
- 17) If you do intend to fit the stainless steel trim, secure it in place using the two remaining screws.
- 18) Restore the power and switch on.

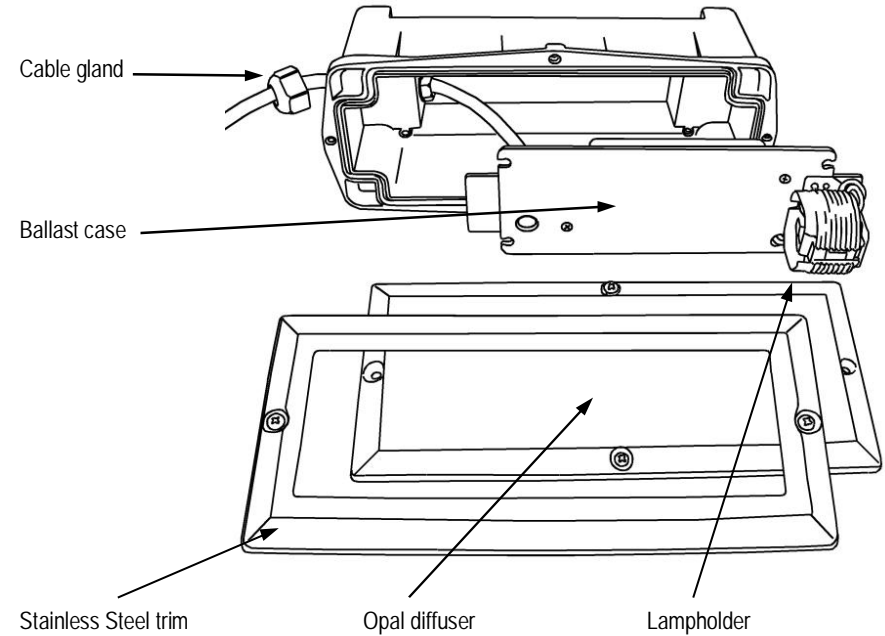

To remove ballast case

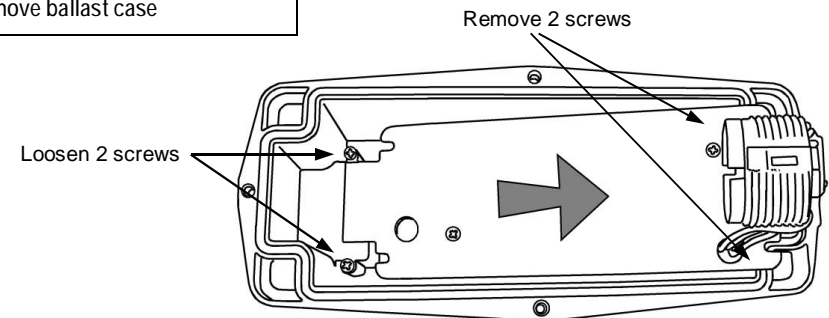

Safety markings:

